

DEPARTMENT'S BOOKLET

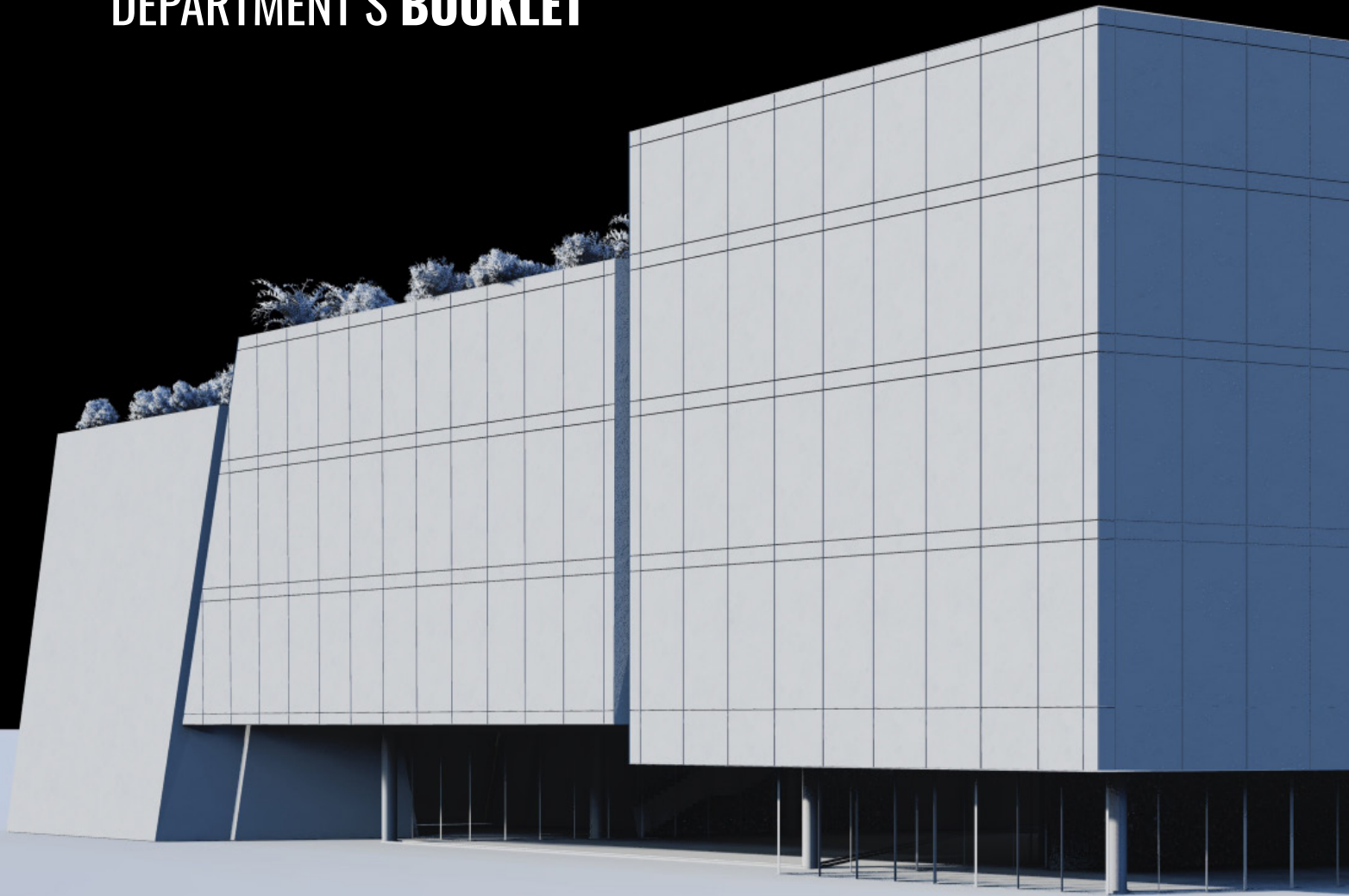

A DESIGN PROPOSAL BY
**DELOVAN
DELAWER**

M.Sc. Diploma at Középtanszék - BME
Consultant: Dr. Schrammel **Zoltan**

Budapest University of Technology and Economics
Faculty of Architecture
Department of Public Building Design

This document was created for the department
of Public Building Design at the Architecture
Faculty, consulted by Dr. Schrammel **Zoltan**

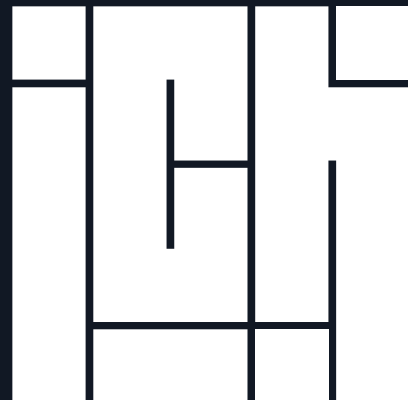

**International
Community Hub
in Amsterdam**



M Ű E G Y E T E M 1 7 8 2



INTERNATIONAL COMMUNITY HUB IN AMSTERDAM

Project Description: The function of the project is to serve the community of the Czaar Peterbuurt in Amsterdam, and integrate the international students and newcomers with the locals and create a homogenous mixture of cultures at the vibrant heart of the tolerant city of Amsterdam, the design proposal of the International Community Hub is composed of compact masses, that truly merge to create a central compact inner core, in which, a very energy efficient design is housed. This compact core starts from the first floor up, leaving the ground level completely public. Since this building is to be the first built structure on the site, the design intends to leave it accessible by all the public, just as they may use the street, or the site within the Funnenpark previously and not take that away from them, as the design truly aims to serve the local community in every way.

Three monumental stairs lead to the upper volumes from the open central space, and take the visitors and the project's and/or site's users to the entertainment, integration, relaxation, and administration space. The Activities of entertainment and interactive or integrative are housed within Cultural Platforms, Lecture Halls, Multi-Purpose Halls and Lounges, in addition to a completely public space which is the Co-Existing Meditation Hall.

These three monumental entrances act like a tripod holding the building up, but not only that, just like a community leans on Social/cultural values, Educational principles, and Humane and Coherence virtues, each monumental entrance leads to one of these specific activities, hence, they sourced the namesake for each, The Coherence-, The Social-, and The Educational- Monumental Entrance Point.

TABLE OF CONTENTS

04	1. ICH INTRO [THE MAIN Characteristics OF ICH + FUNCTIONAL DESCRIPTION]
06	2. INTRODUCTION [LOCATION AND HISTORY BRIEF + CZAAR PETERBUURT HISTORY + CLIMATE, NOISE, SOIL AND TERRAIN + ARCHITECTURAL ANALYSIS + EXTENDED SITE STUDIES + FUNCTIONAL ANALYSIS + FUNCTIONAL SCHEMA + PRECEDENT STUDIES + THEIR CONCLUSION + EXISTING STRUCTURES ON SITE]
48	3. ICH COMPLEX DESIGN CONCEPT [CONCEPT + INSPIRATIONS + EXPERIMENTAL FORMATION + MODEL + SITE LAYOUT + 3D IMAGERY TO ILLUSTRATE THE DESIGN]
108	4. TECHNICAL INFORMATION OF ICH [FINISHING MATERIAL LIST (FACADE + ROOF) + ARCHITECTURAL STANDARDS]
114	ARCHITECTURAL DRAWINGS [PLANS + SECTIONS + ELEVATIONS + STRUCTURAL DRAWINGS + BUILDING CONSTRUCTION DRAWINGS + DETAILS (SKETCHES) + DETAIL DRAWINGS + DETAIL OF SKIN + DETAILS OF CENTRAL STAIRS + BIM MODEL + SERVICE SYSTEMS 3D MODEL]
	ENERGETICS STUDY DATA AIR FLOW STUDY SOLAR STUDY + SERVICES SITE LAYOUT
	BUILDING CONSTRUCTION STUDY DATA [REQUIREMENTS OF ENERGY, INSULATION, FINISHING + FIRE + WALLS + WIND + ARCHITECTURAL STANDARDS + DETAILS AND CATALOGUES OF USED EQUIPMENTS + ICH U-VALUE CALCULATION]
	STRUCTURE DPT. STUDY DATA [STRUCTURE ALTERNATIVES AND THEIR DESCRIPTIONS + STRUCTURAL ANALYSIS + CALCULATIONS AND STRUCTURAL DETAILS AND DIAGRAMS]
	ANNEX: PROJECT MANAGEMENT STUDY BRIEF [CONSTRUCTION PHASE + PARTICIPANTS IN THE CONSTRUCTION + GOALS OF CONSTRUCTION OF ICH + COSTS OF CONSTRUCTION OF ICH + SCHEDULE OF CONSTRUCTION OF ICH + CIRCUMSTANCES OF CONSTRUCTION MINDMAP OF ICH + FUNCTIONAL SCHEMA + COST ESTIMATION + A: SCHEDULE OF CONSTRUCTION (NETWORK METHOD + TIMELINE + GANTT CHART) + B: CONSTRUCTION TECHNOLOGY (THE ACTIVITIES DESCRIPTION) + C: TECHNOLOGIES, EQUIPMENT, AND TOOLS]
246	ICH LAYERS



ICH (INTERNATIONAL COMMUNITY HUB IN AMSTERDAM)

CZAAR PETERSTRAAT, 1018 AP, AMSTERDAM, NETHERLANDS

1

Architectural Designer
Delovan Delawer

Location
Amsterdam, Netherlands

Client
Középtanszék BME + UNI

Architectural Consultant
Dr. Schrammel Zoltán
Construction Technology and
Management Consultant

Dr. Lepel Adrienn
Building Energetics and
Plumbing Consultant
Dr. Zoltán Magyar

Mechanics, Materials and
Structures Consultant

Dr. Hegyi Dezső
Building Construction
Consultant
Dömötör Álmos
Local Dutch Opponent
Ommar & Rühl Architects



THE MAIN CHARACTERISTICS OF ICH

The design proposal of the International Community Hub is composed of compact masses, that truly merge to create a central compact inner core, in which, a very energy efficient design is housed. This compact core starts from the first floor up, leaving the ground level

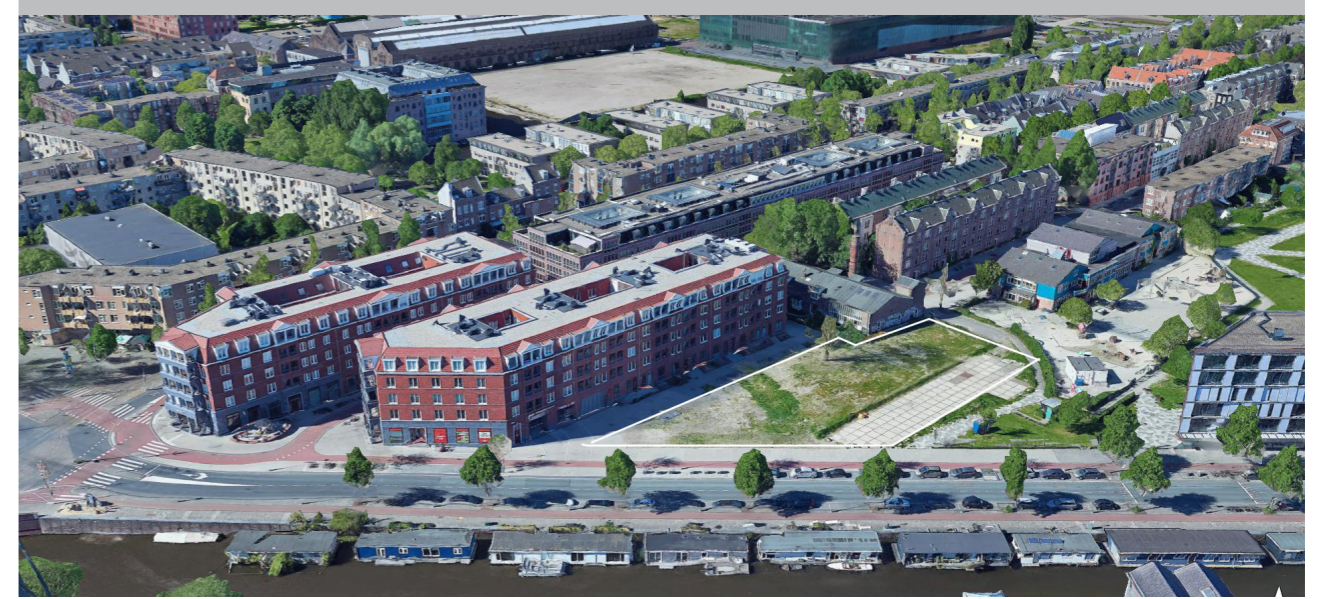

completely public. since this building is to be the first built structure on the site, the design intends to leave it accessible by all the public, just as they may use the street, or the site within the Funnenpark previously and not take that away from them, as the design truly aims to serve the local community in every way.

Three monumental stairs lead to the upper volumes from the open central space, and take the visitors and the project's and/or site's users to the entertainment, integration, relaxation, and administration space. The Activities of entertainment and interactive or integrative are housed within Cultural Platforms, Lecture Halls, Multi-Purpose Halls and Lounges, in addition to a completely public space which is the Co-Existing Meditation Hall. These three monumental entrances act like a tripod holding the building up, but not only that, just like a community leans on Social/cultural values, Educational principles, and Humane and Coherence virtues, each monumental entrance leads to one of these specific activities, hence, they sourced the namesake for each, The Coherence-, The Social-, and The Educational- Monumental Entrance Point.

ICH CONFORMS TO THE CZAAR PETERBUURT AREA, AND ITS ENVIRONMENT, AND TO THE NEEDS OF THE PEOPLE OF AMSTERDAM'S CITY CENTER AND EASTERN DOCKYARD TOO. ITS FORM DOES NOT IMPLY THE CONVENTIONAL UNDERSTANDING OF FORM FOLLOWS FUNCTION, BUT COMES WITH A MORE ENHANCED UNDERSTAND OF FORM FOLLOWS COMMUNITY AND ENVIRONMENT.

FUNCTIONAL DESCRIPTION

The function of the project is to serve the community of the Czaar Peterbuurt in Amsterdam, and integrate the international students and newcomers with the locals of Amsterdam, the design proposal of the ICH is composed of compact masses, that merge to create a central inner core, in which, a very energy efficient design is housed. Three monumental stairs lead to the upper volumes from the open central space, and take the visitors to the entertainment, integration, relaxation, and administrative space. The Activities are housed within Cultural Platforms, Lecture Halls, Multi-Purpose Halls and Lounges, in addition to a completely public space which is the Co-Existing Meditation Hall.

INTRODUCTION (BRIEF, LOCATION AND HISTORIC BACKGROUND)

ICH (INTERNATIONAL COMMUNITY HUB IN AMSTERDAM)

2

In 2015, over a billion people moved: 244 million traveled to another country and 763 million moved inside their nation of origin. Looking for another chance, for a superior personal satisfaction, to get away from savagery or a continuous catastrophe.

As the century attracted to close, a wide based recovery of the focal city as the work environment, live and study has ruled the scene. This has prompted an expansion in populace and an adjustment in socioeconomics. Among them are youthful grown-ups. Just about 30 percent of the youthful grown-ups matured 18-34 in the United States are either outside conceived or of remote parentage. While Canada saw a 18.5% expansion in 2018, global understudies concentrating in Amsterdam saw an increment of 8%.

In quest for better chances and fulfillment, more individuals are deciding to travel abroad. This pattern is imagined to develop as the change gets reflected in the urban texture of the city. The influx of vagrants and displaced people has seen the fringes of numerous urban areas growing over the most recent couple of decades. Starting at 2017, Amsterdam's populace is foreseen to increment by 23% up to a little more than a million out of 2040, generally because of relocation. Over the previous century, one of the greatest urban advancement challenge

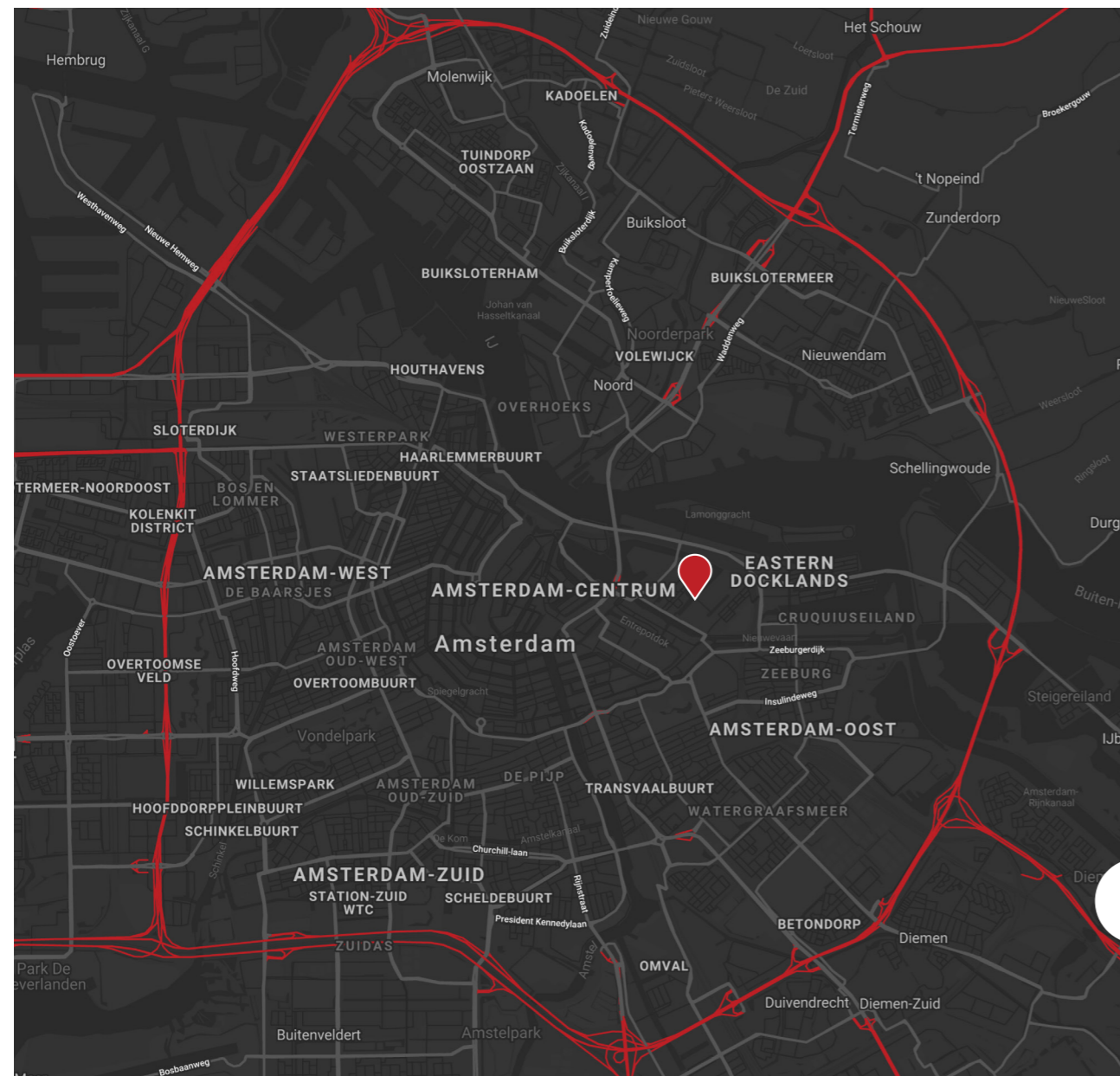

for the city has been densification. Nineteenth century structures are being wrecked to oblige the developing lodging emergency. Alongside development on green wedges and land extension outside the managerial fringes has prompted the present city texture.

Despite the fact that the city chamber has proposed lodging answers for incorporate the changeless occupants. It's the transitory occupants like worldwide understudies, wanting to examine in the city who are at misfortune. The world's twelfth best city as far as 'quality of life', Amsterdam is known for its social inclusivity. In spite of government strategies defined for consideration of vagrants, the internationalization of instruction has been a point of discussion for quite a long time. 2018 report by OECD revealed that about 51% of the populace concurs that outsiders who live in the city are not all around incorporated.

Intercommunal collaborations must happen for individuals to modify. These changes are intricate, vague and convey a fleeting feeling of character. A space, a venturing stone that encourages the procedure of consideration into city texture. A road that encourages understudies feel had a place with society and help in safeguarding one's character. Brief is to plan a public venue for 100 global understudies (age 19-35). The production of the space means to empower worldwide understudies to find passages into well-known circles of the city and find a cover with local people.

With respect to Czaar Peterbuurt itself, it was at one time a mechanical suburb, that has bloomed into a center point of nourishment, drink and shopping since 2014. The territory legitimately fringes the downtown area. The site is neighboring blend utilized advancement, with eateries and staple story delineating the ground floor while accomodation and offices sit on. Private plot and youngster care focus finishes the relevant texture. Site is 2 km away from Amsterdam School of Arts, 1.8 km away from Academy of Architecture (same bearing) and 1.3 km away from junior college - Volksuniversiteit Amsterdam. Sports Complex at a mobile separation of 300 m provides requirment of physical movement.



1920-1939 (Belt '20-'40)

1940-1969 (General Expansion Plan)

1970 - Now

CZAAR PETERBUURT HISTORY

The Czaar Peterbuurt , named after Tsar Peter the Great , is a neighborhood in Amsterdam , in the Dutch province of Noord-Holland . It is located in the Amsterdam City Center district , east of the Eastern Islands . The Czaar Peterstraat is located in the center of the neighborhood . Characteristic of the neighborhood is the nineteenth-century character: narrow streets, little public greenery and small, shallow houses. The Czaar Peterbuurt is bordered on the south by the Oostenburgergracht and on the north by the Piet Heinkade . The side streets of the Czaar Peterstraat are: Eerste Coehoornstraat, Cruquiusstraat, Eerste Leeghwaterstraat, Tweede Leeghwaterstraat and Lijndenstraat. The other streets of the Czaar Peterbuurt are: Blankenstraat, Kraijenhoffstraat, Conradstraat and Tweede Coehoornstraat .

The Eastern Islands were built in the second half of the 17th century . There were many shipyards here, including the Admiralty of Amsterdam and the Dutch East India Company . The area in which the Czaar Peterbuurt now lies was pumped into the IJ in 1663 . Here were the lines of the VOC where the ropes were turned for the Company. At the northern tip of the later Czaar Peterbuurt was the Keerweer, the point where the ships turned.

Near the Czaar Peterbuurt was the stronghold , De Funen , until the 19th century . Remnants of the foundation were found during excavation work. There were several windmills in this area. The last remaining mill was the cocoa mill , De Goede Verwachting ,, which was demolished in 1906 to make way for home construction. The first residential building in this neighborhood dates from the last quarter of the 19th century. An example of this are the Double Houses . Czaar Peterstraat also has the origins of the metal and port unions of the former NVV and the first strikers took to the streets.

Nowadays, Small households with relatively low incomes have long been overrepresented in the Czaar Peterbuurt. In May 2003 , the district council adopted the Plan of Approach for the Czaar Peterbuurt, because the neighborhood was characterized by a lot of crime and nuisance and many poor and small houses. A large number of outdated social rental homes has been replaced by larger rental and owner-occupied homes, shops , small businesses in the creative sector , studios and the hospitality industry . On the west and east side of the neighborhood, along the Oostenburgervaart and on the Funen (the former site of Van Gend en Loos), many new homes have been built. The quality of the Czaar Peterbuurt has been greatly improved. There are also more well-to-do residents living in the Czaar Peterbuurt. With the arrival of tram line 10 in 2004, the connection to the city center has also improved.

Regarding Transportation, Since May 2004, another tram has been running on Czaar Peterstraat. First line 10 and since service implementation as a result of the opening of the North / South line in 2018 line 7 . From 1884 there was a horse tram connection with Kadijksplein. The former depot and stable building on Tweede Leeghwaterstraat is still present. In 1906 this line was electrified and extended to Central Station and was given the line number 13 . From 1932, line 19 took its place. This was replaced by a bus service in 1938 , with which the Eastern Islands lost their tram connection. Between 1938 and 1983 this line has driven under different numbers: 19, M, 6 and 29 . In 1983 the route through Czaar Peterstraat was taken over by line 28 , and from 1994 to 2004 line 32 . Bus lines 28 and 32 no longer drove via the Prins Hendrikkade , but a longer route via Kattenburgerstraat and Piet Heinkade .

Since 1874, the railway line from Amsterdam Central to Amsterdam Muiderpoort station has been running on the north side of Czaar Peterstraat . Until the thirties this floor lay. As part of the Oost railway works, the track was raised and a viaduct was built at the end of the street. This now forms the border with the area of the Rietlanden , part of the Eastern Docklands , now a new-build district.



SITE ANALYSIS

SITE LOCATION

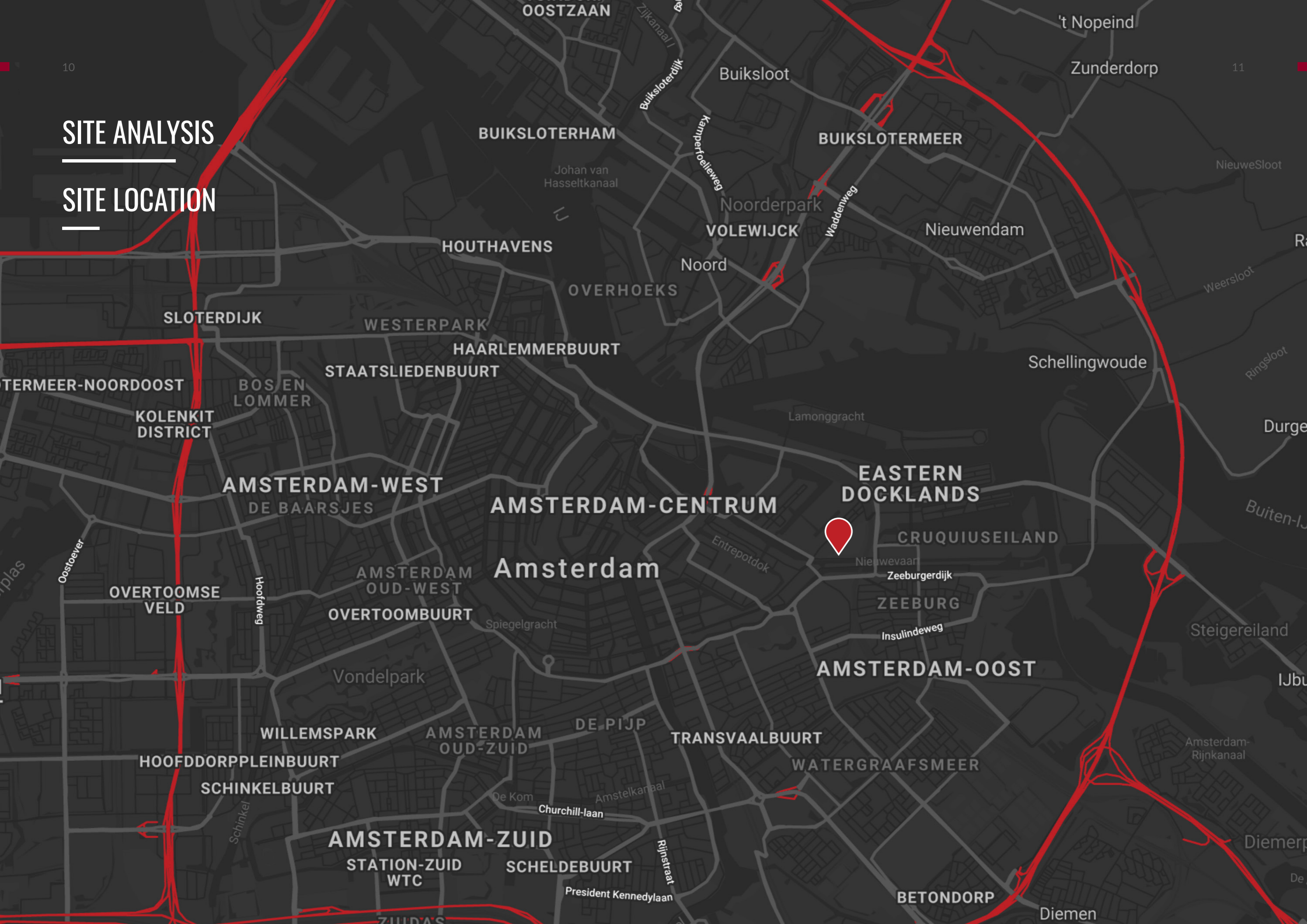

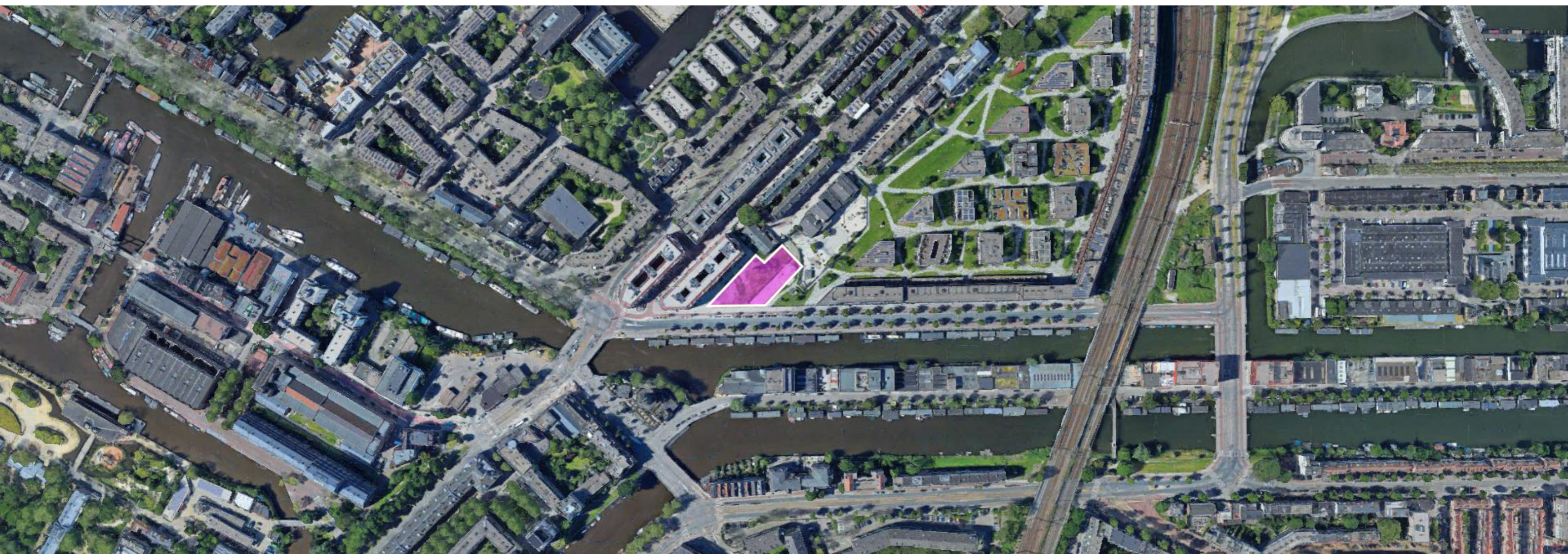
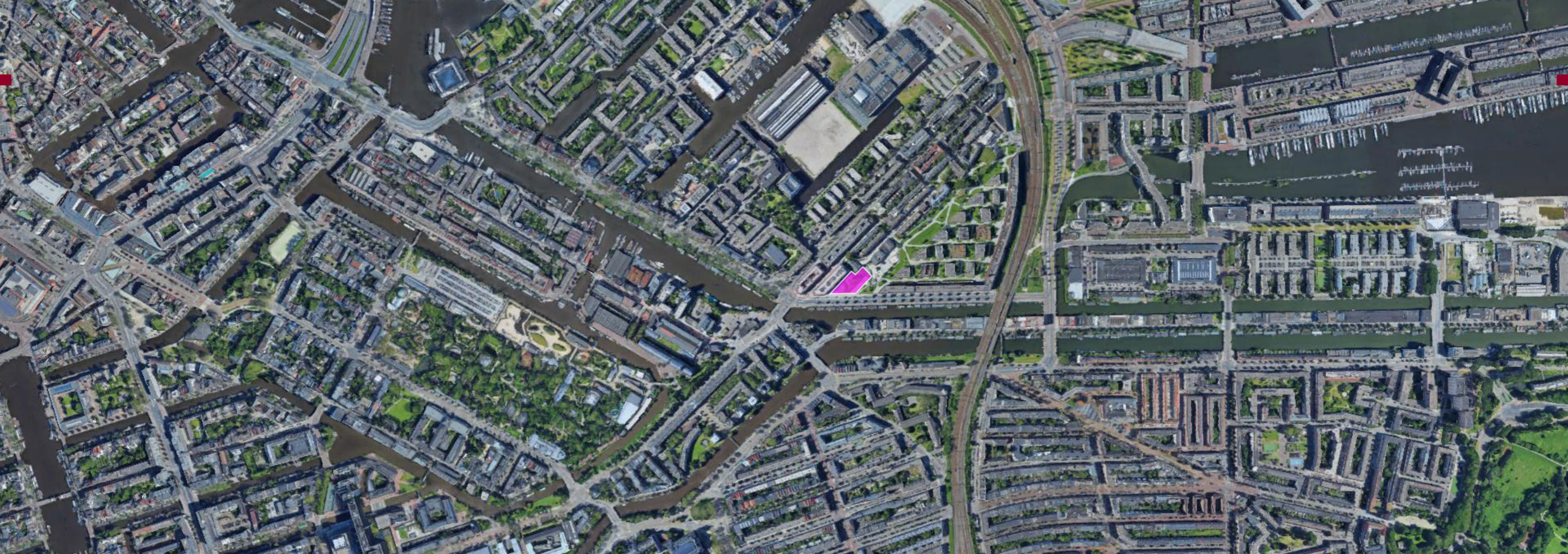



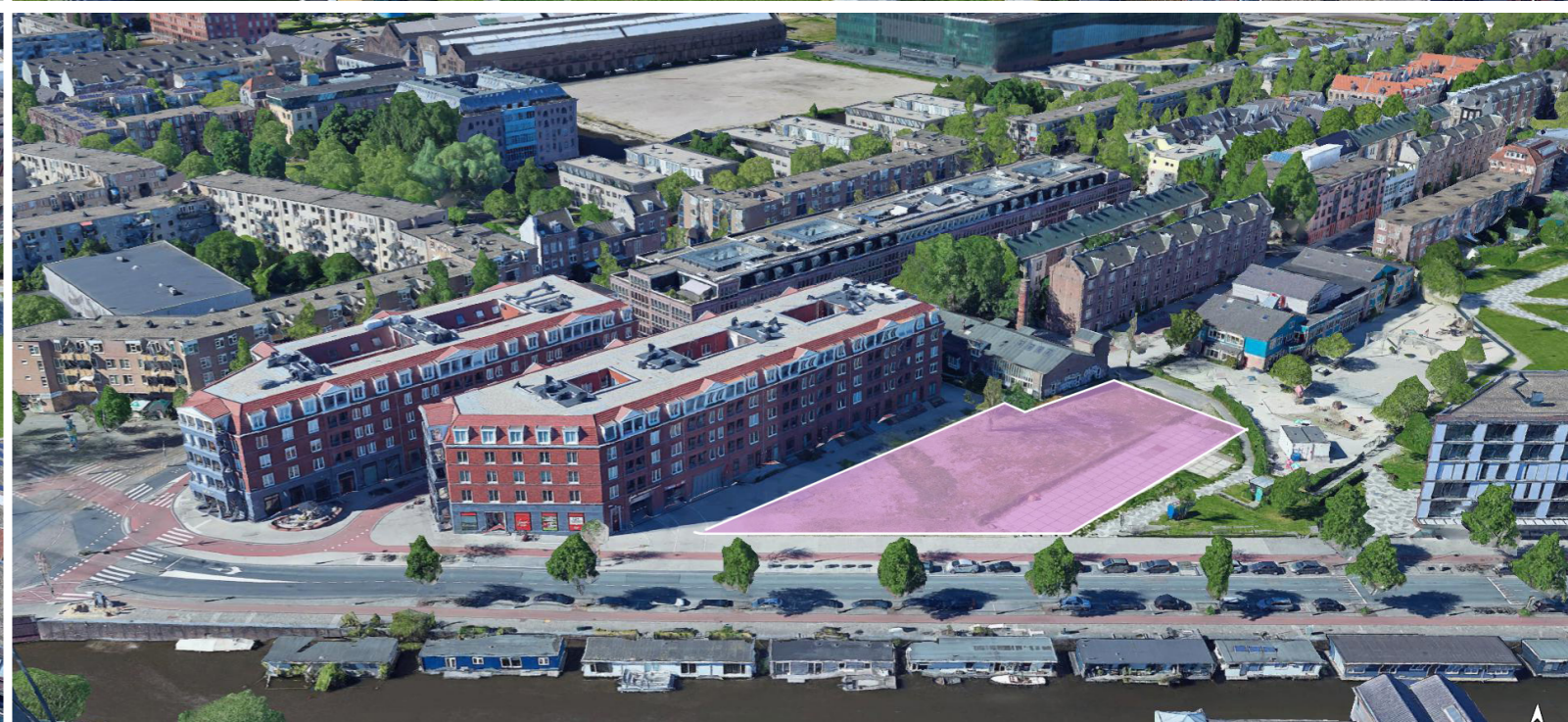
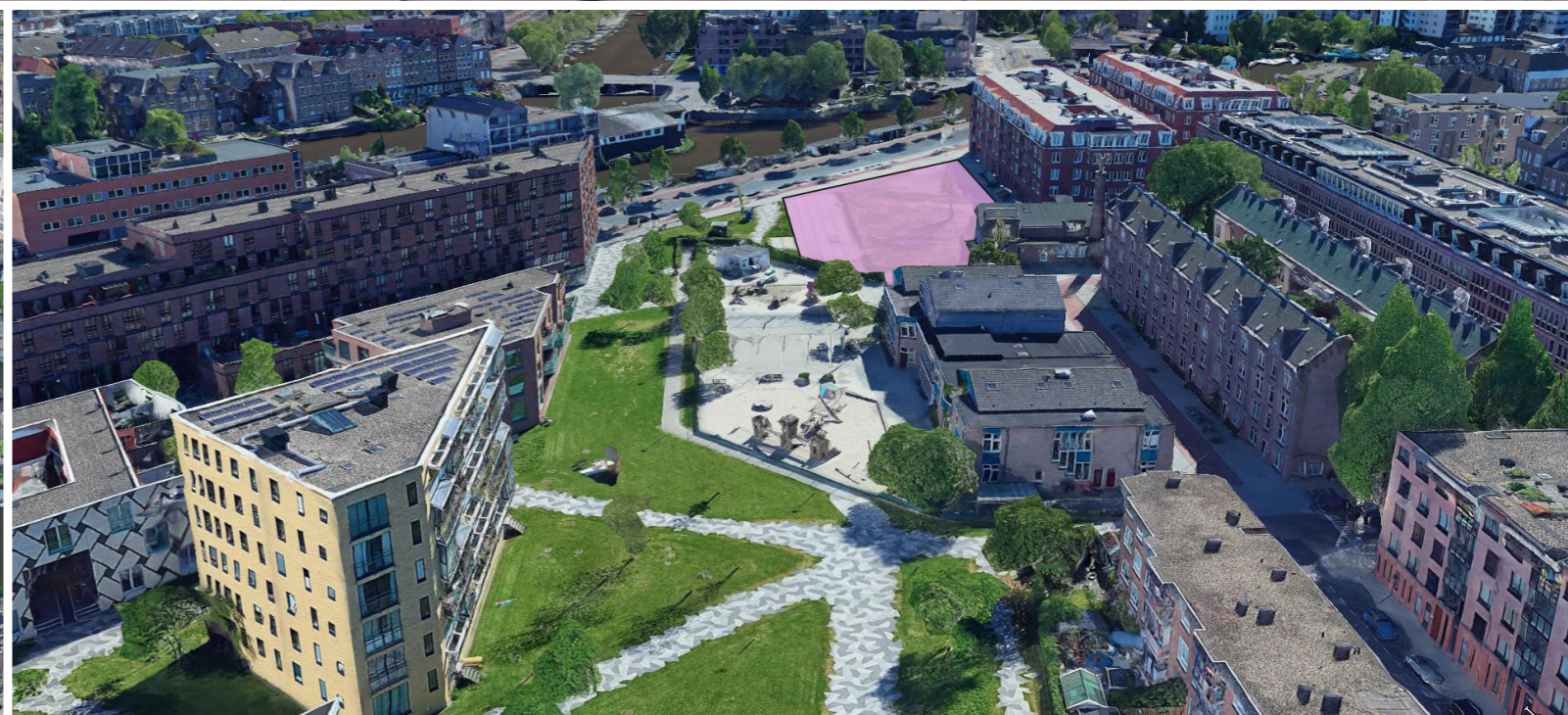
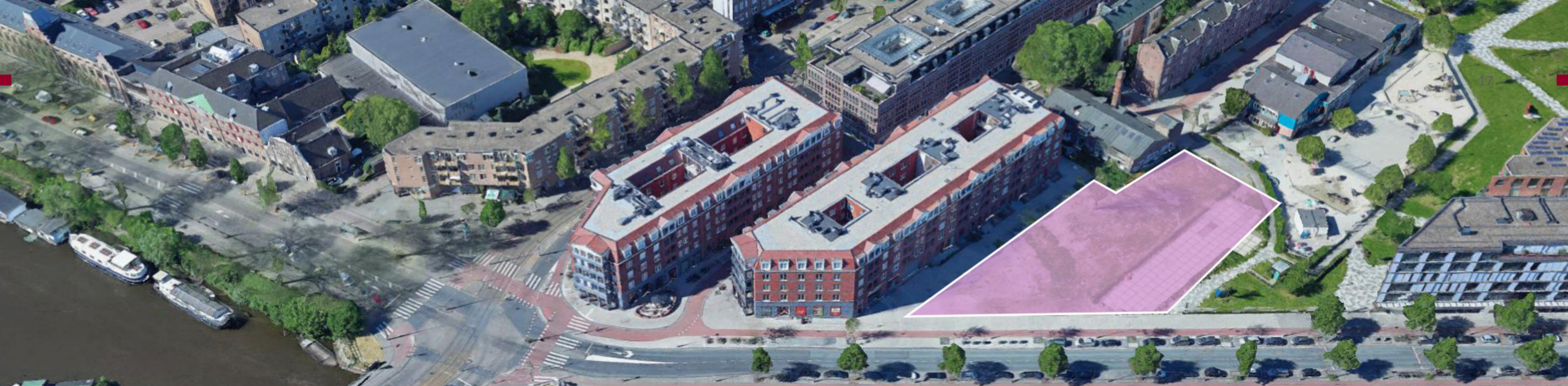

SITE ANALYSIS

SITE IMAGING









SITE ANALYSIS

TRANSPORTATION NETWORK

TRAM AND METRO LINES

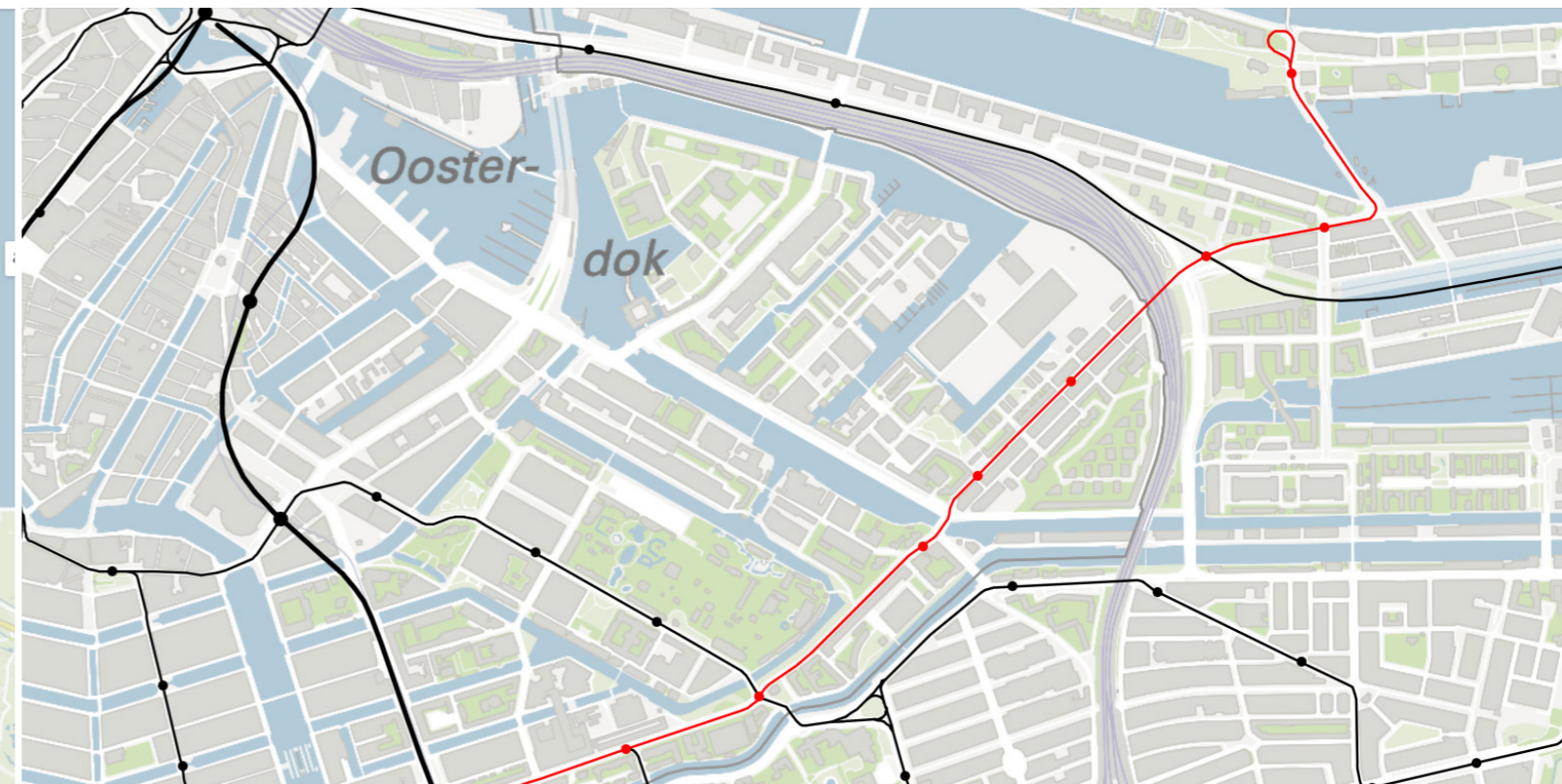
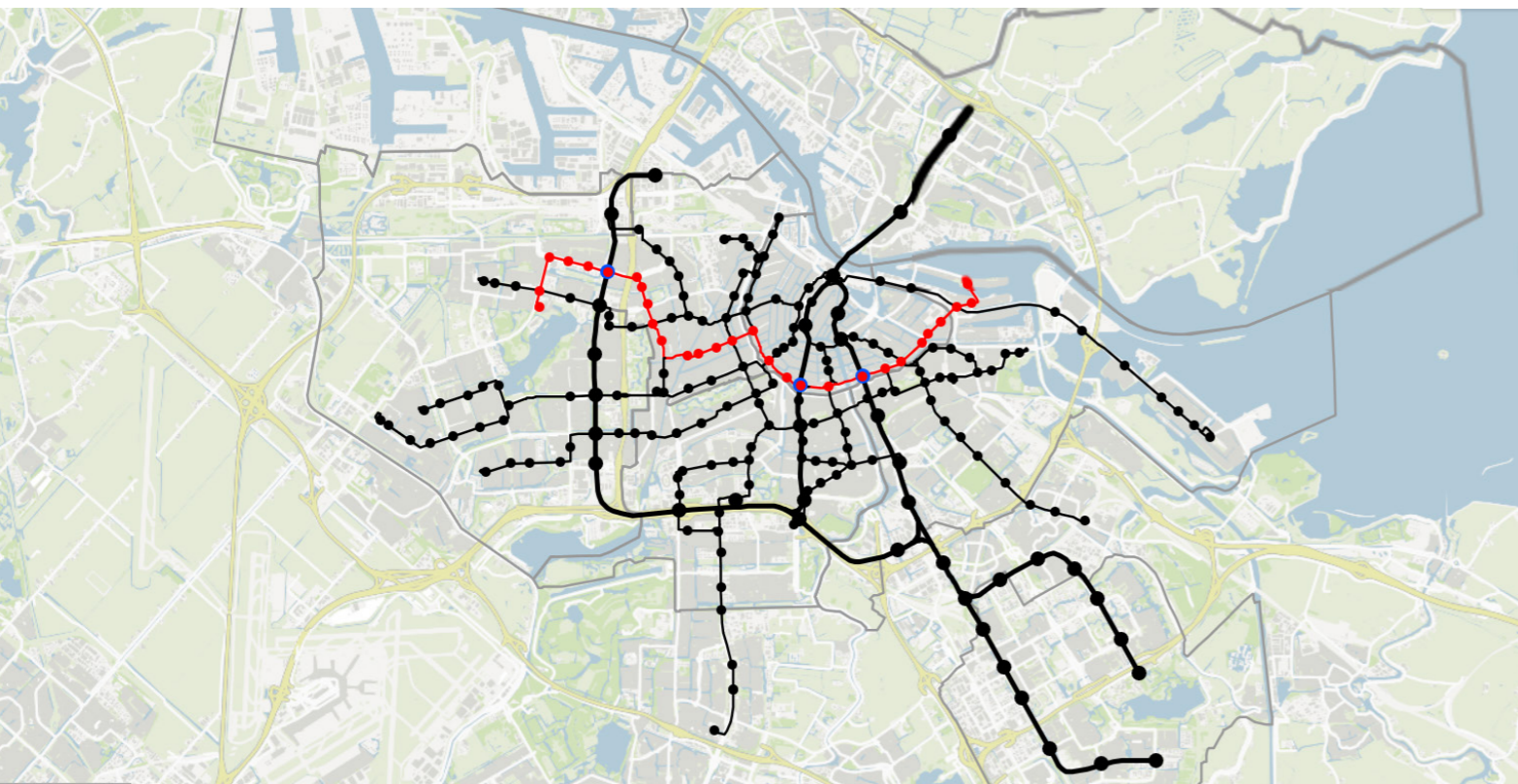
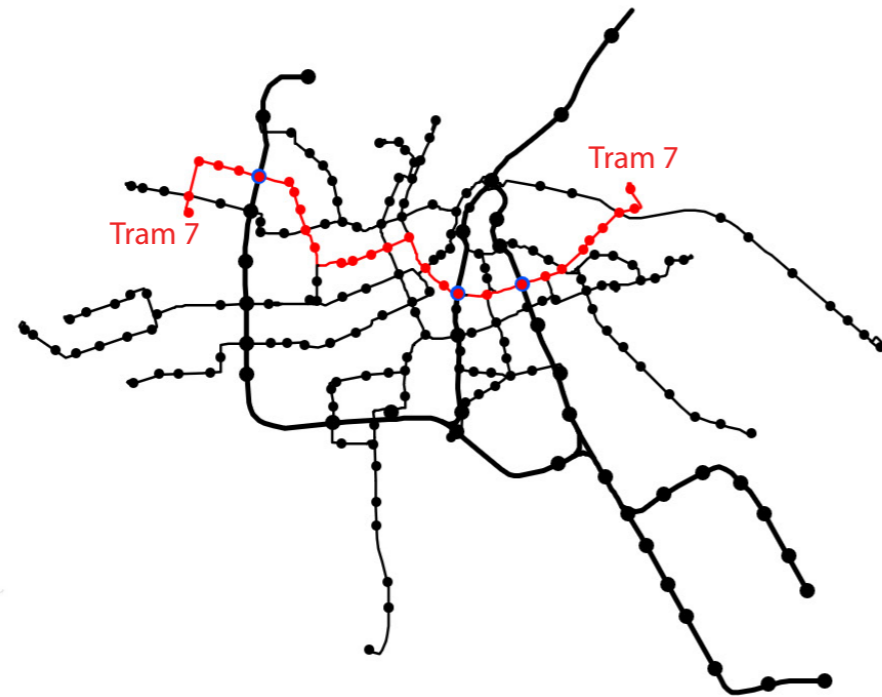

SITE ANALYSIS

VEGETATION ON SITE

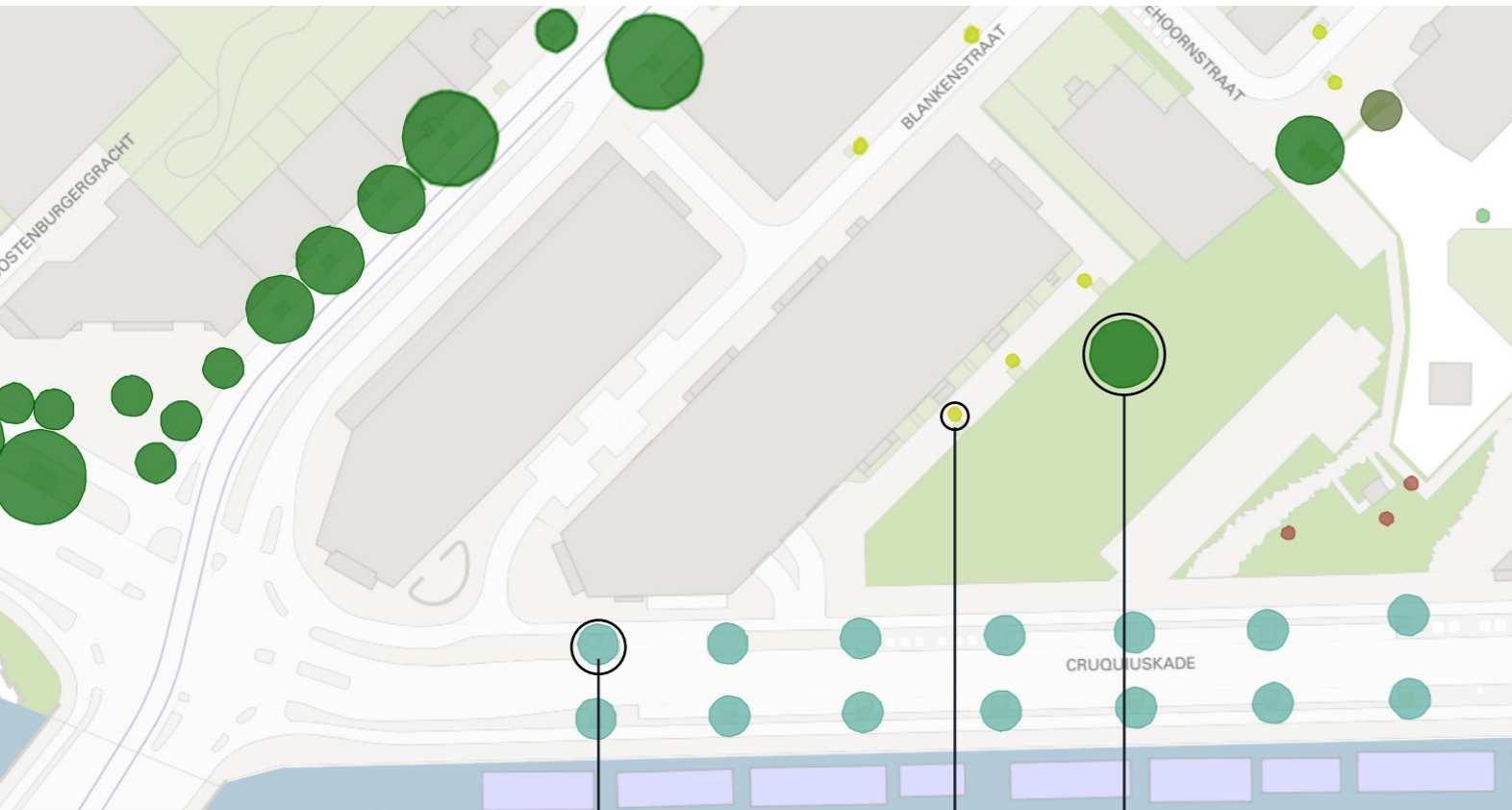

Els (cultuurvariëteit)
 2278607
 Alnus spaethii 'Spaeth'
 Boom niet vrij uitgroeiend
 9-12 m

Kobushi-magnolia
 2278609
 Magnolia kobus
 Boom niet vrij uitgroeiend
 tot 6 m

Huntingdon-iep
 344957
 Ulmus hollandica 'Vegeta'
 Boom niet vrij uitgroeiend
 15-18 m
 1940

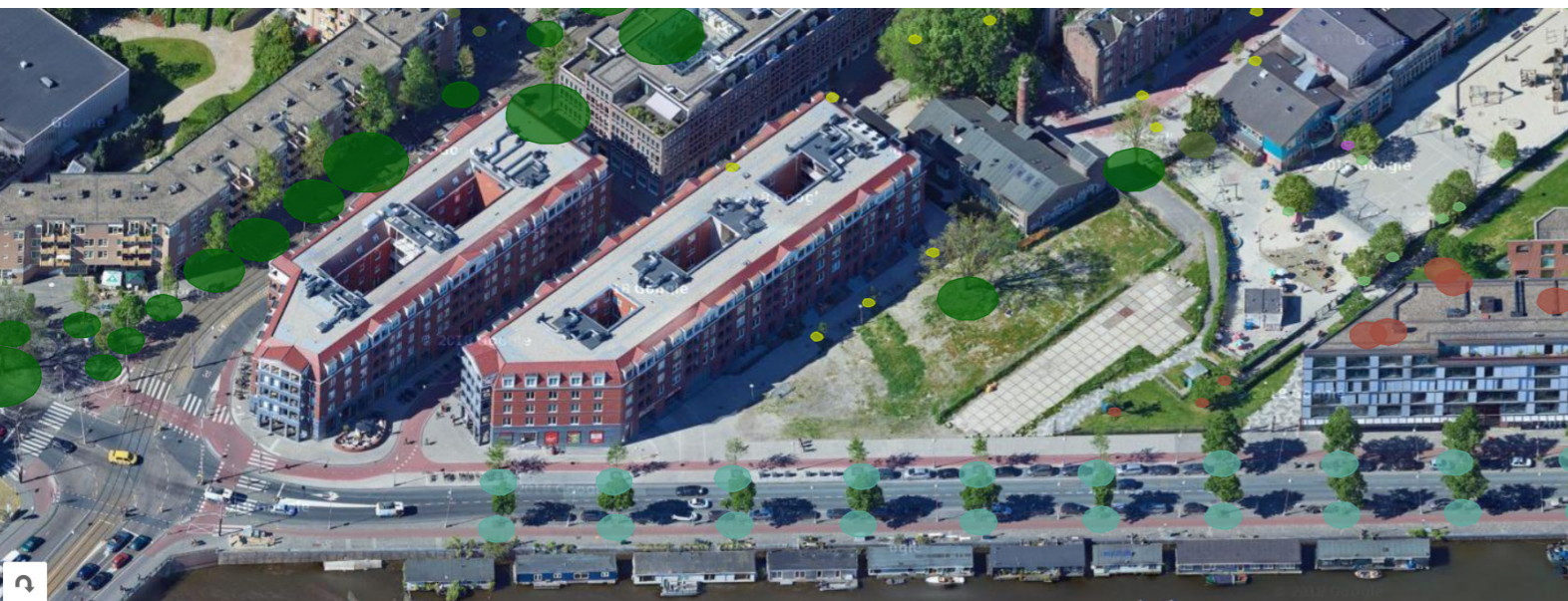

SITE ANALYSIS

SPORTS FACILITIES

- | Sports accommodations | | Public sports spot |
|-----------------------------|-----------------------------|----------------------|
| Source: Function map | | Source: field work |
| ■ Stadium - Ice rink | ■ Swimming pool | ● Skate |
| ■ Sports hall - Tennis hall | ■ Gym - Fitness - Yoga room | ● Tennis |
| ■ Small-scale buildings | ■ Water sports building | ● Basketball |
| ■ Sports park | ● Other | ● Soccer |
| | | ● Jeu de boules |
| | | ● Fitness / Bootcamp |
| | | ● Beachvolley |
| | | ● Table tennis |

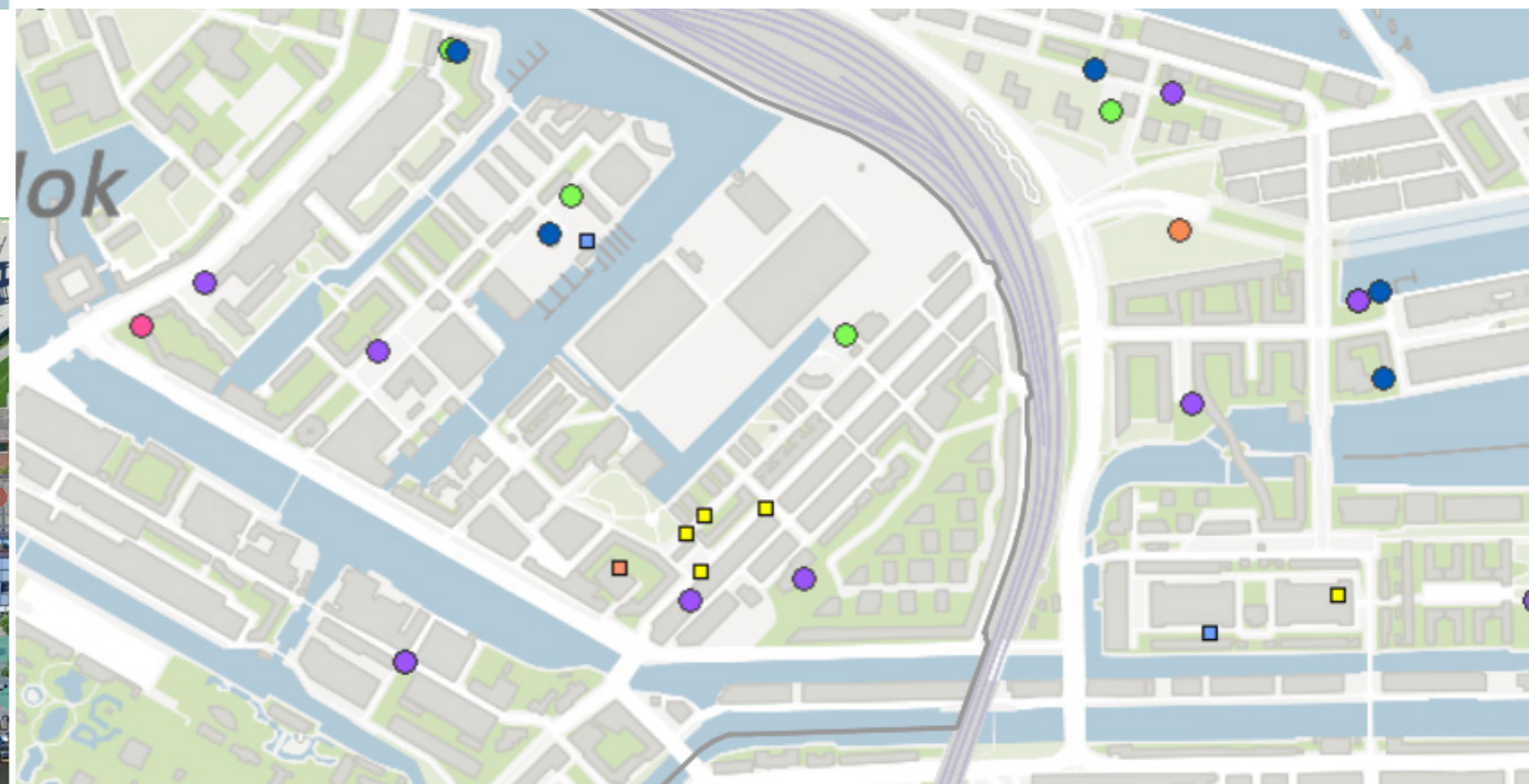

SITE ANALYSIS

SITE MORPHOLOGY

Building age (oldest building in block)

- Before 1860
- 1860-1919
- 1920-1939
- 1940-1969
- 1970-1985
- 1986-1999
- After 2000

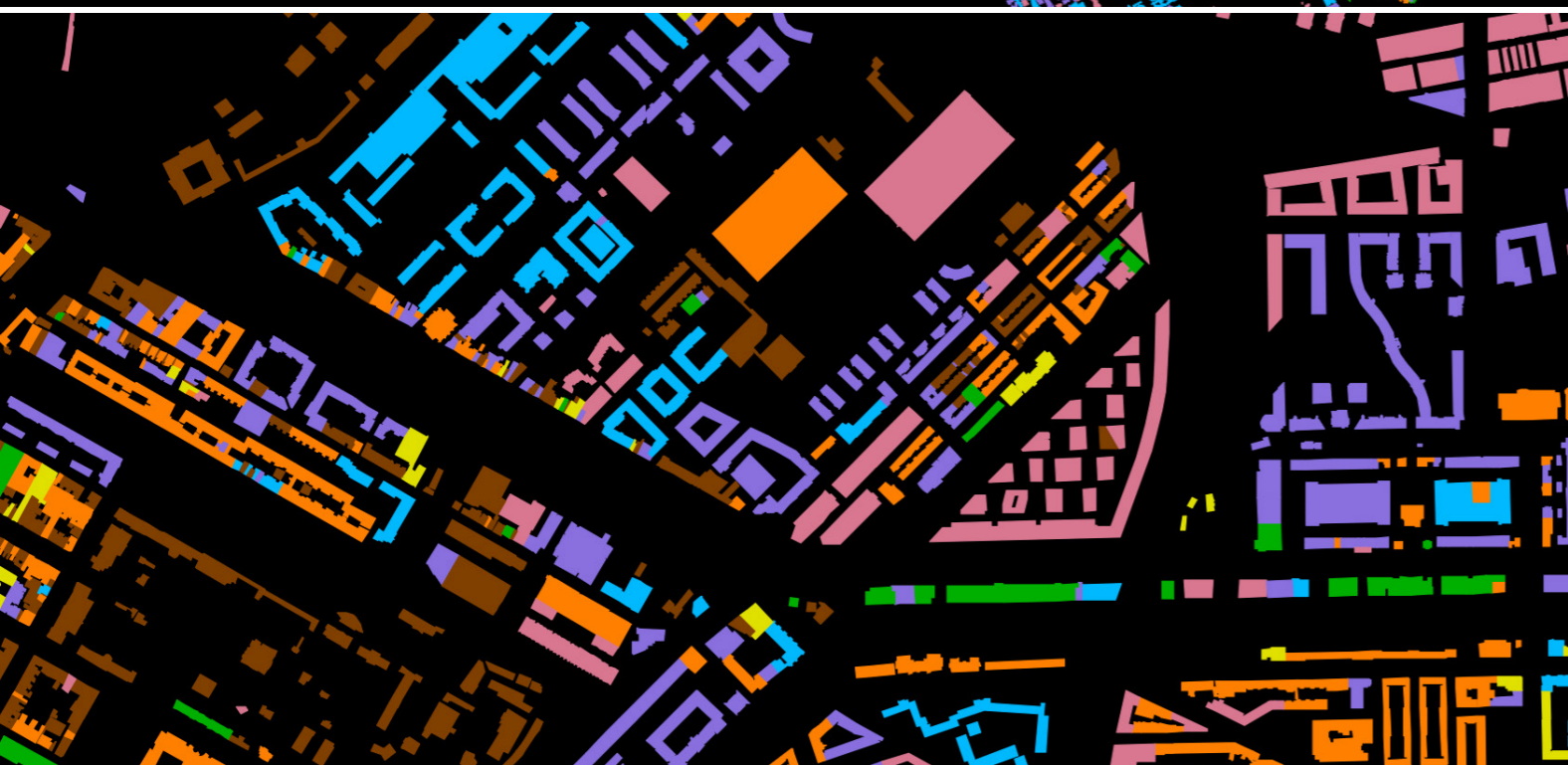
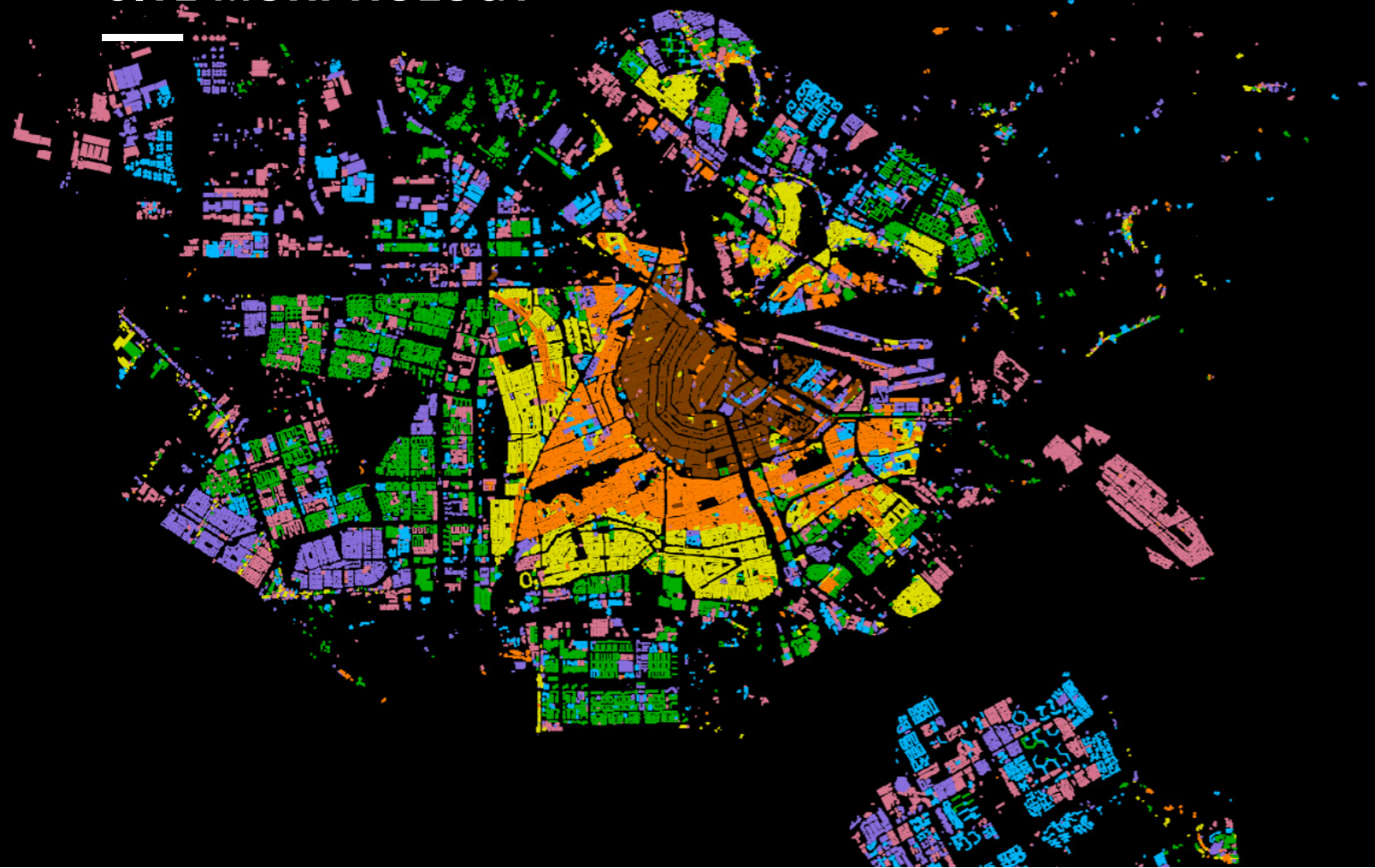

SITE ANALYSIS

YOUTH AND STUDENT HOUSING

- Existing
- Plan in development

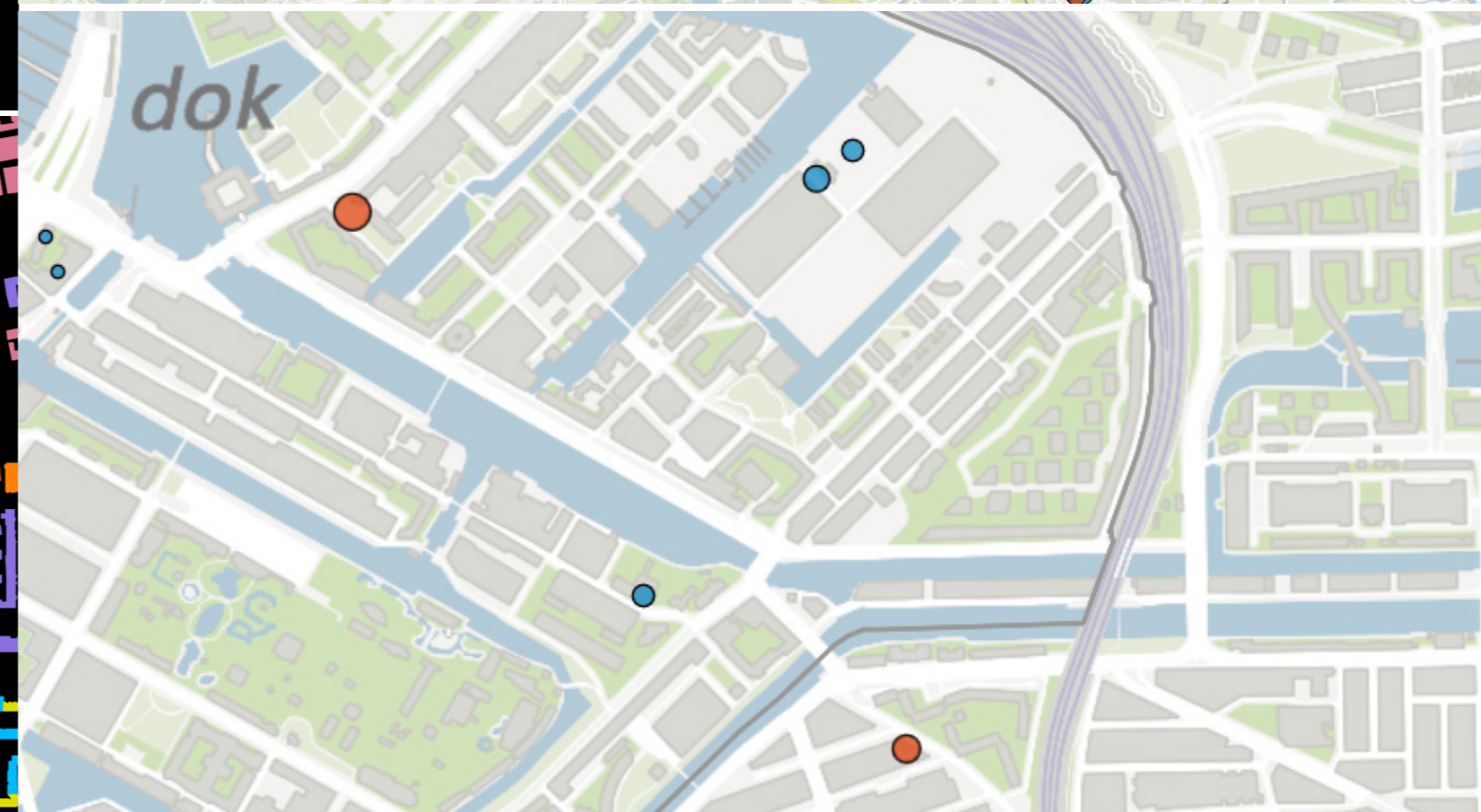
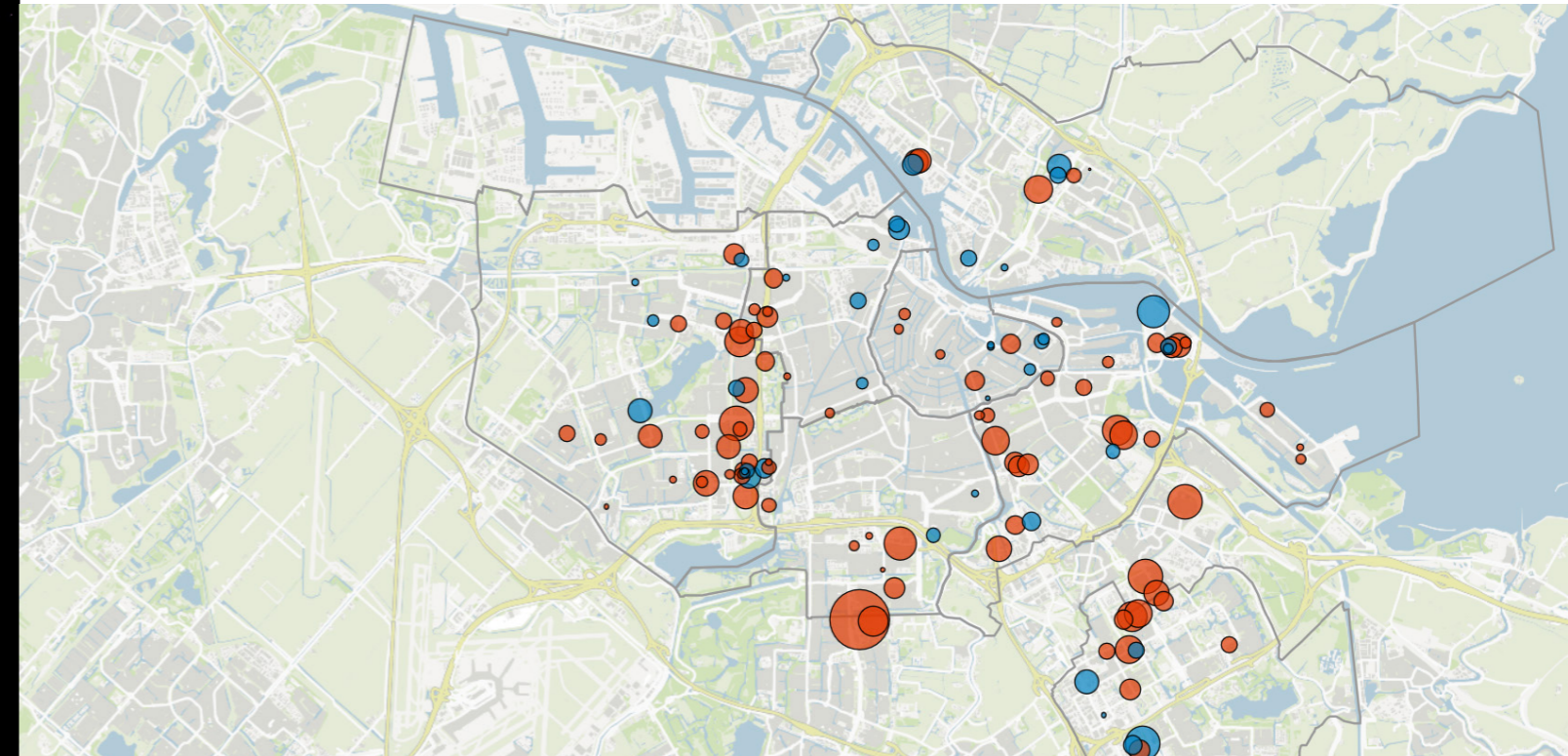

SITE ANALYSIS

NOISE MAP DATA OF 2018

- 70 dB of meer
- 65-70 dB
- 60-65 dB
- 55-60 dB

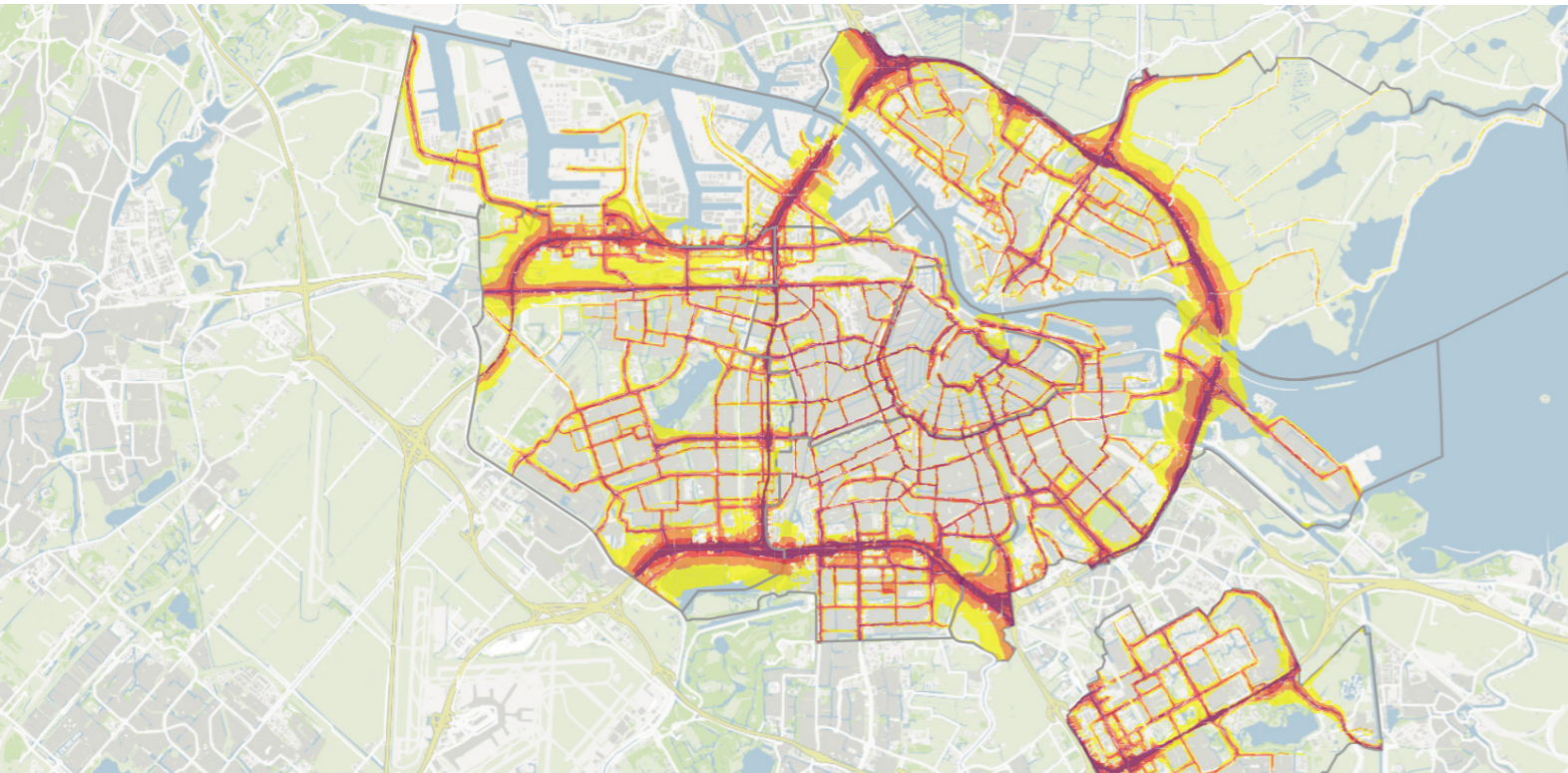

SITE ANALYSIS

DISTRICT HEATING AND COOLING

- Heating transport
- Heating district
- Cooling transport
- Cooling district

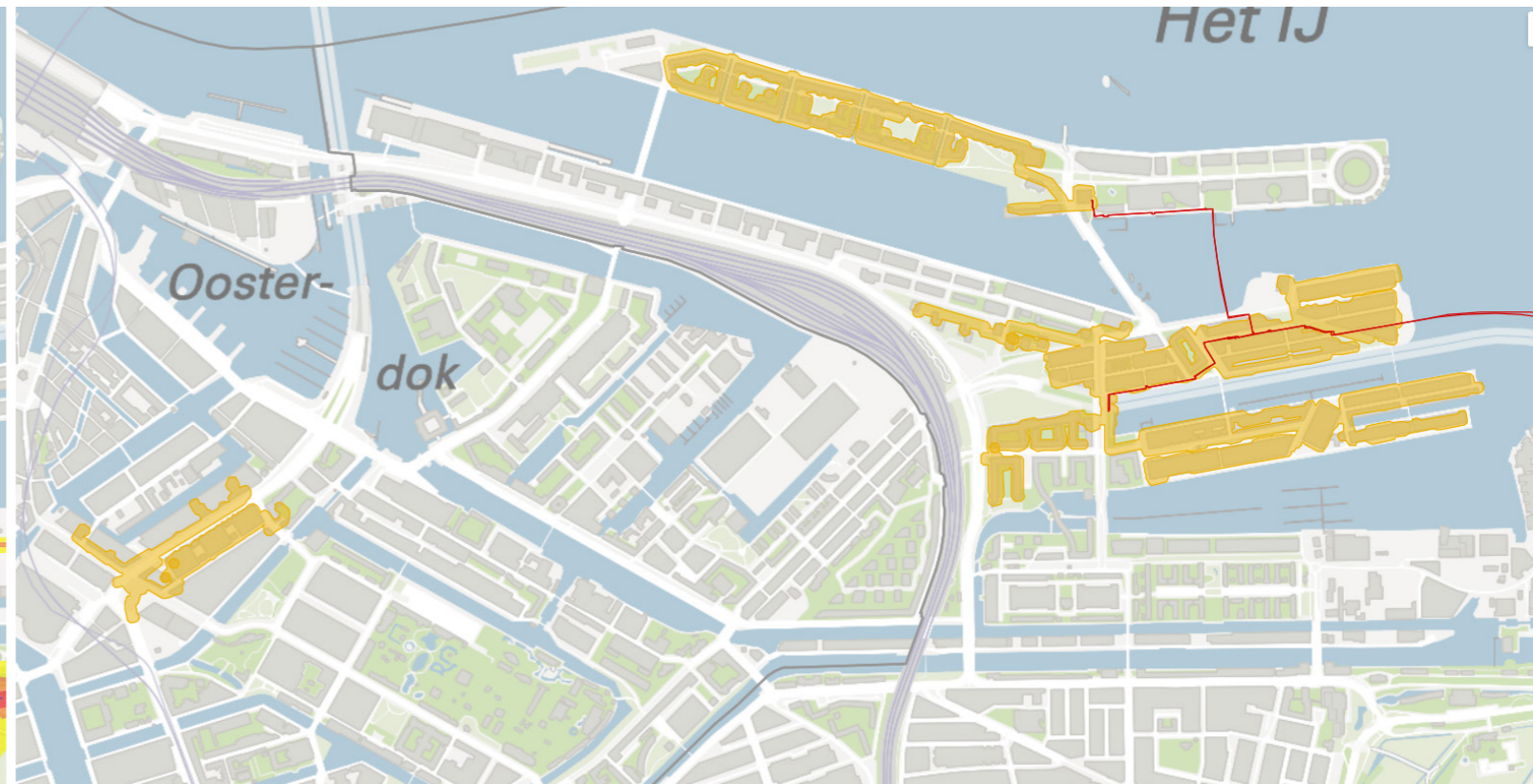
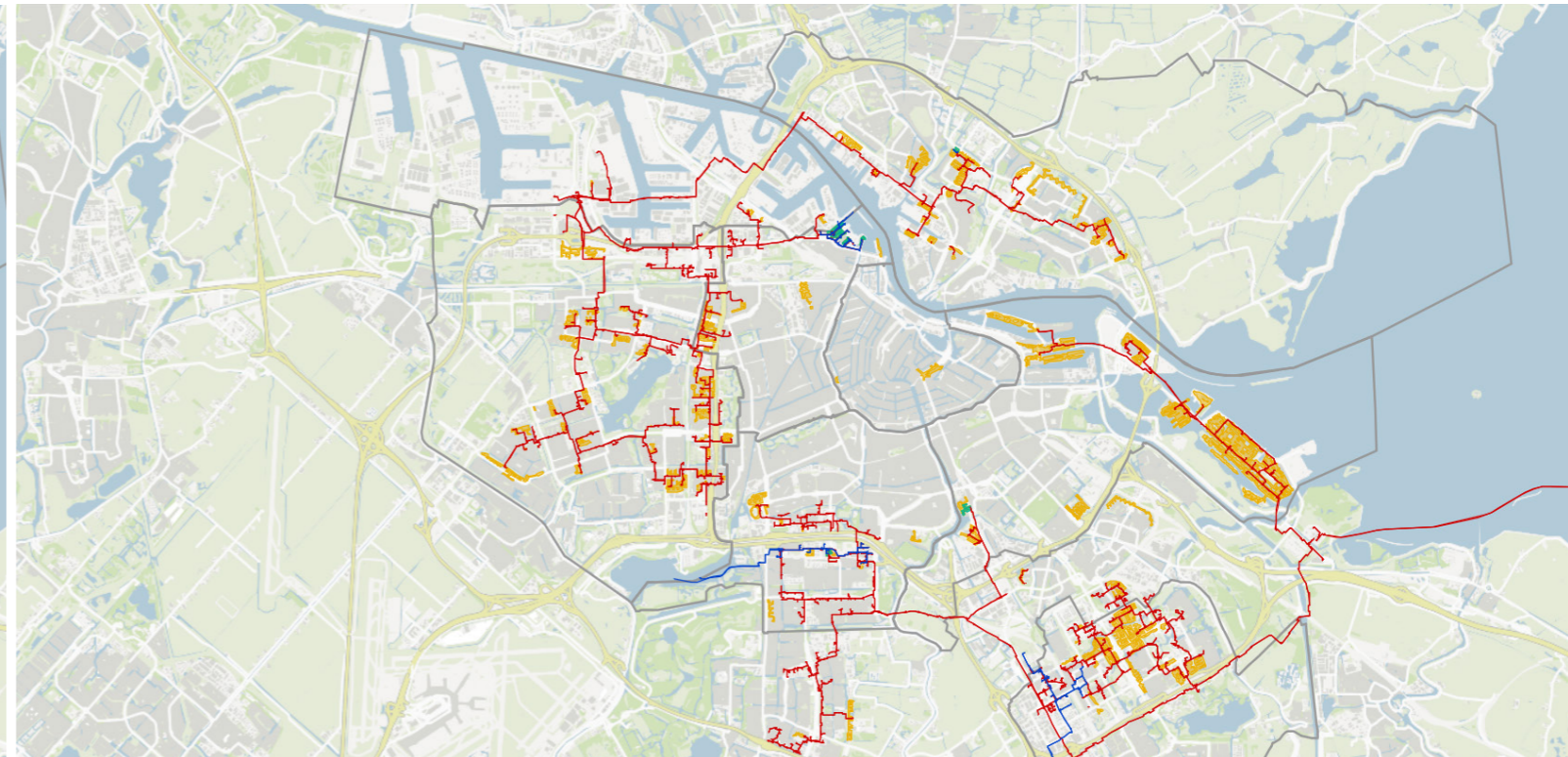

SITE ANALYSIS

LAND-USE MAP

- Homes
- Services
- Services - Homes
- Work
- Work - Homes
- Work - Services
- Work - Services - Homes

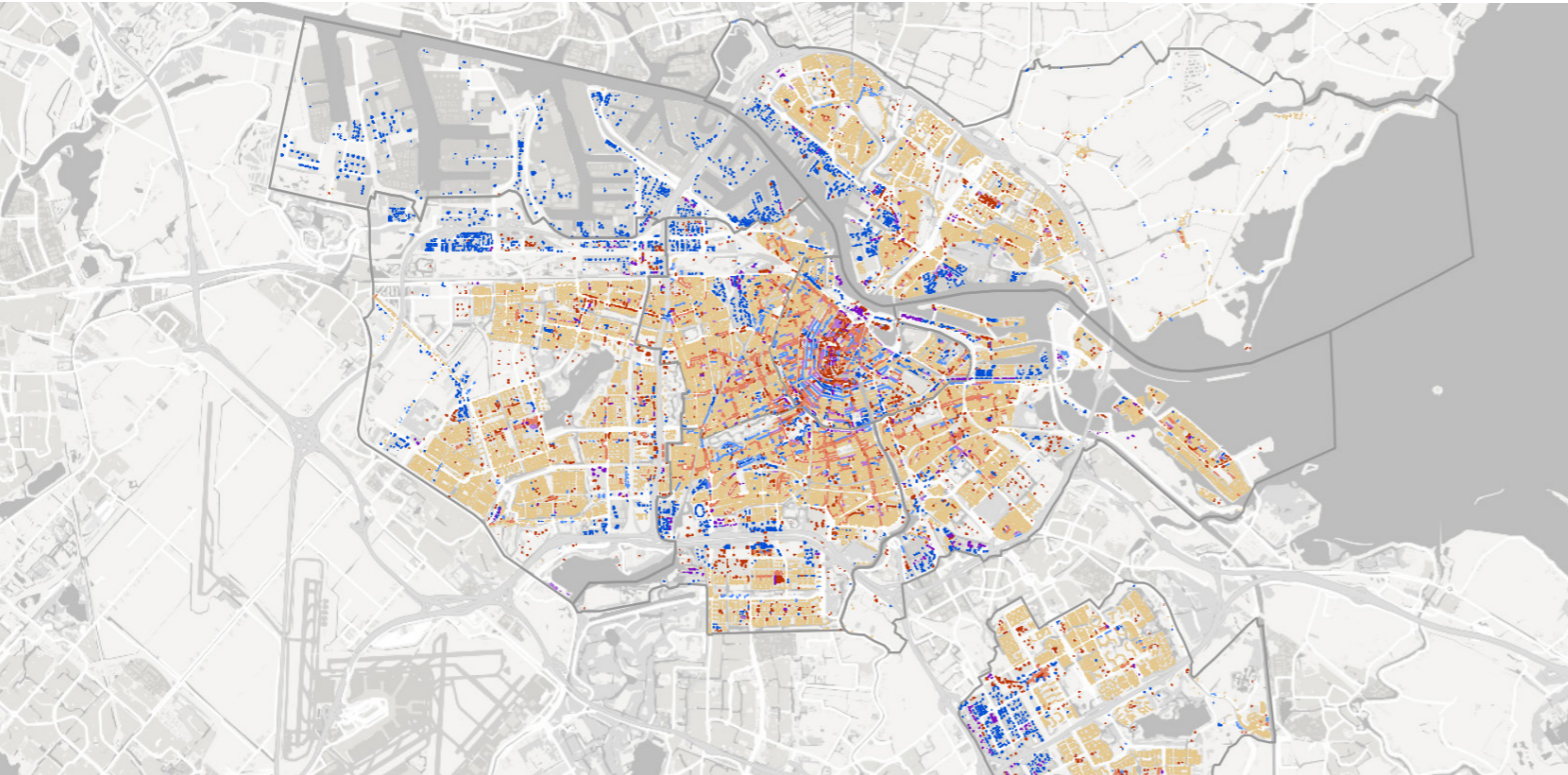

SITE ANALYSIS

FUNCTIONS NON-RESIDENTIAL

- Retail
- Restaurants and bars
- Hotels
- Culture
- Sports and recreation
- Education
- Religion
- Care
- Community center
- Offices
- Enterprises
- Art/craft workspace
- Agricultural business
- Storage and distribution
- Utility
- Unclear function

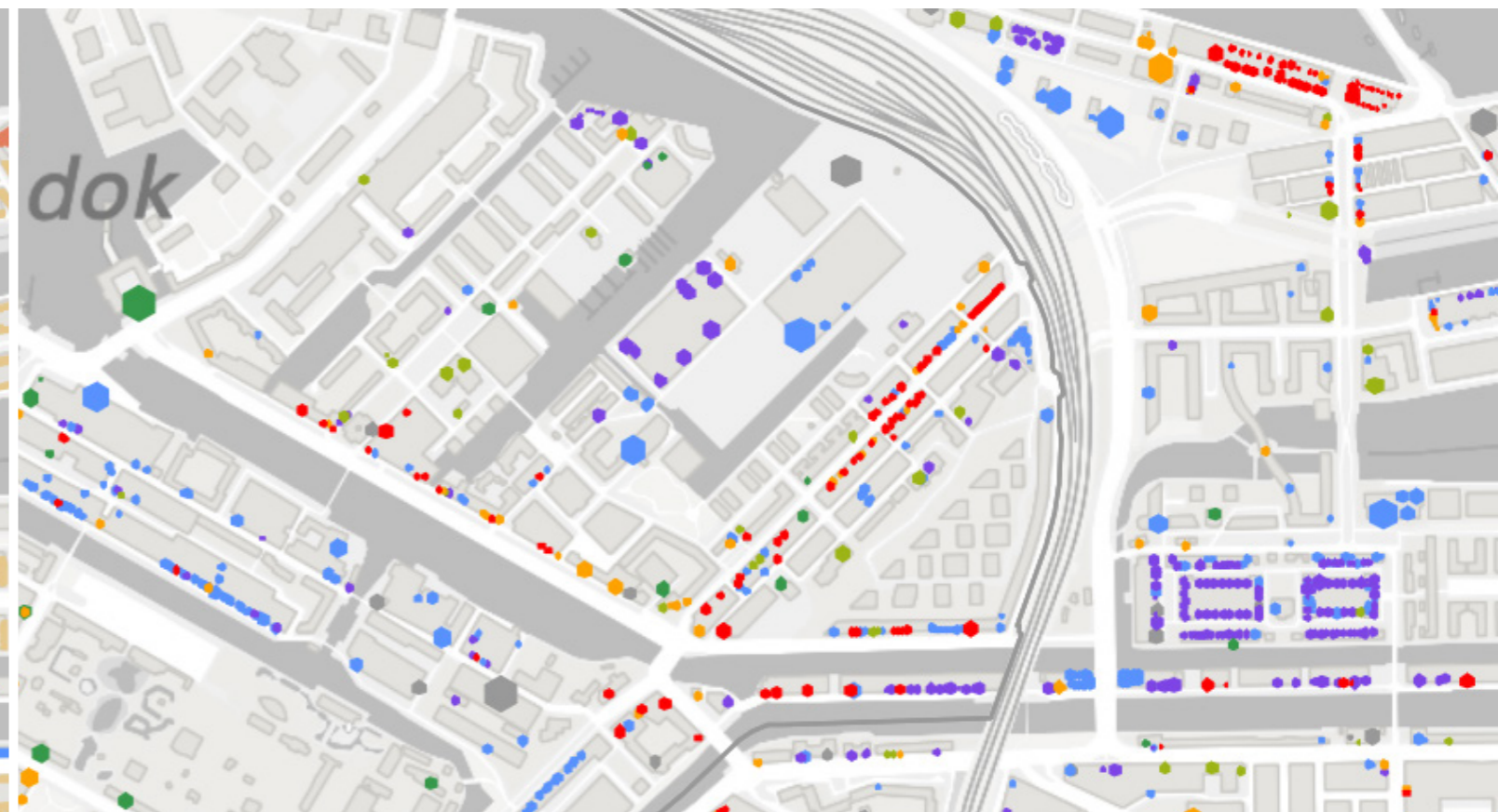
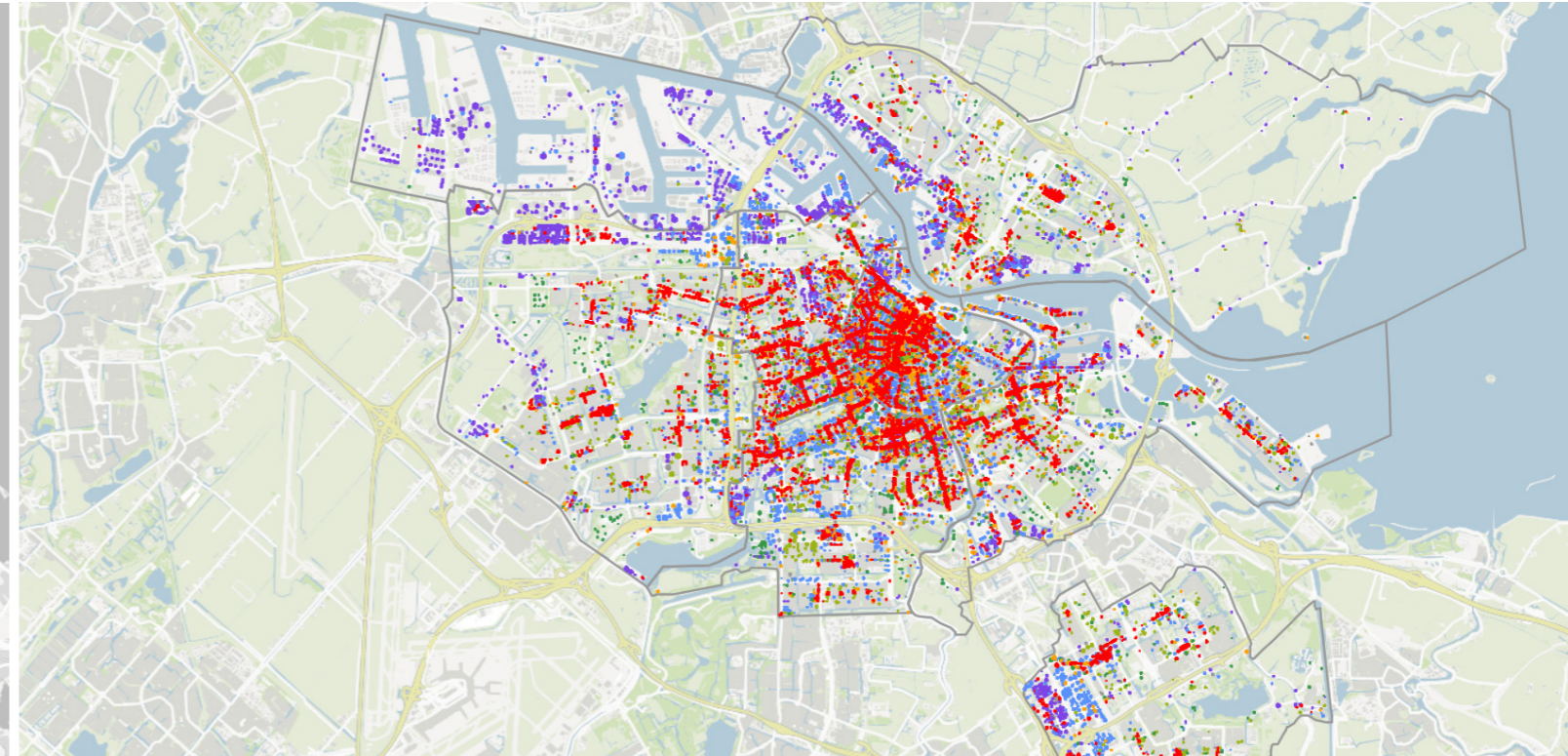

SITE ANALYSIS

CLIMATE ADAPTATION

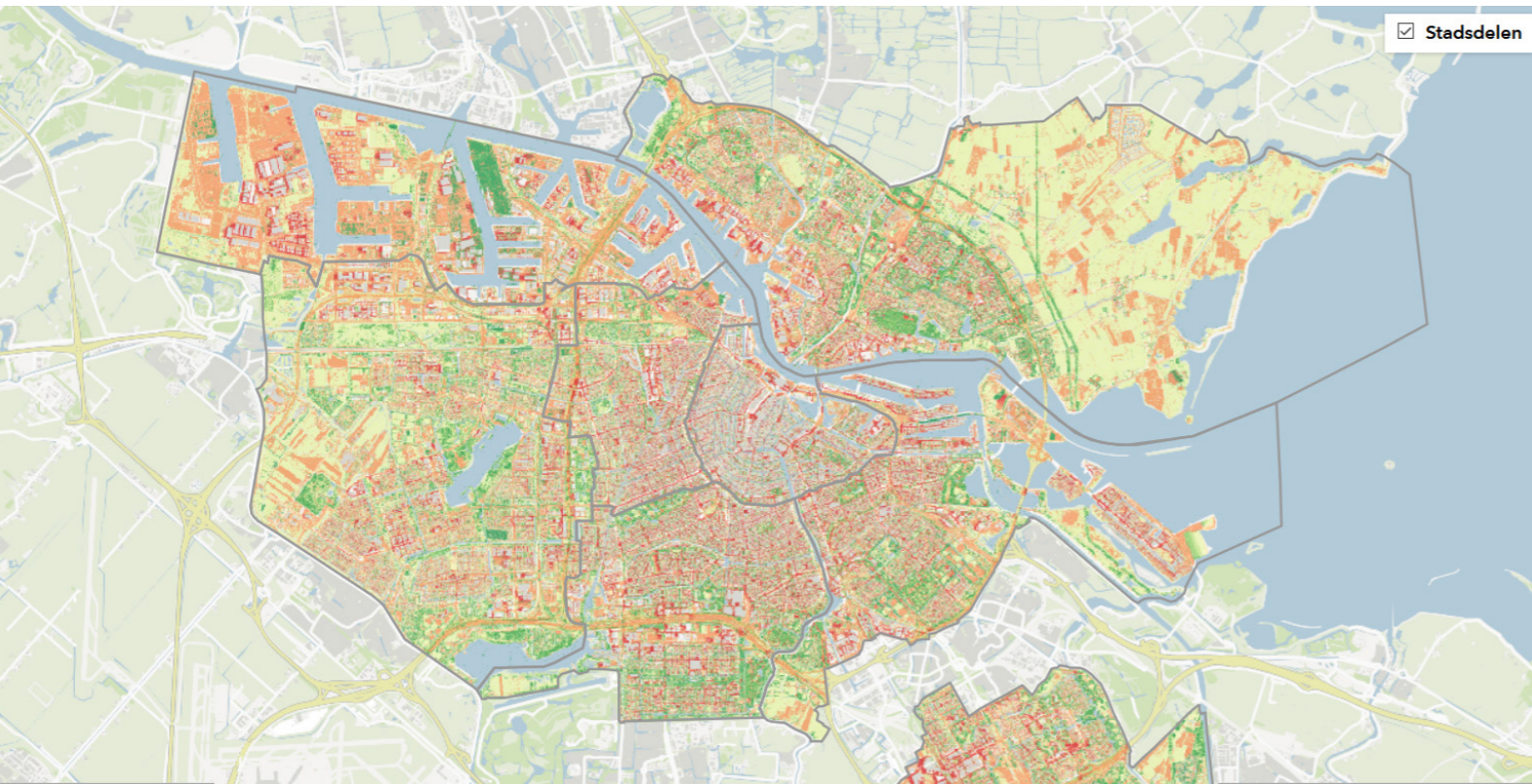
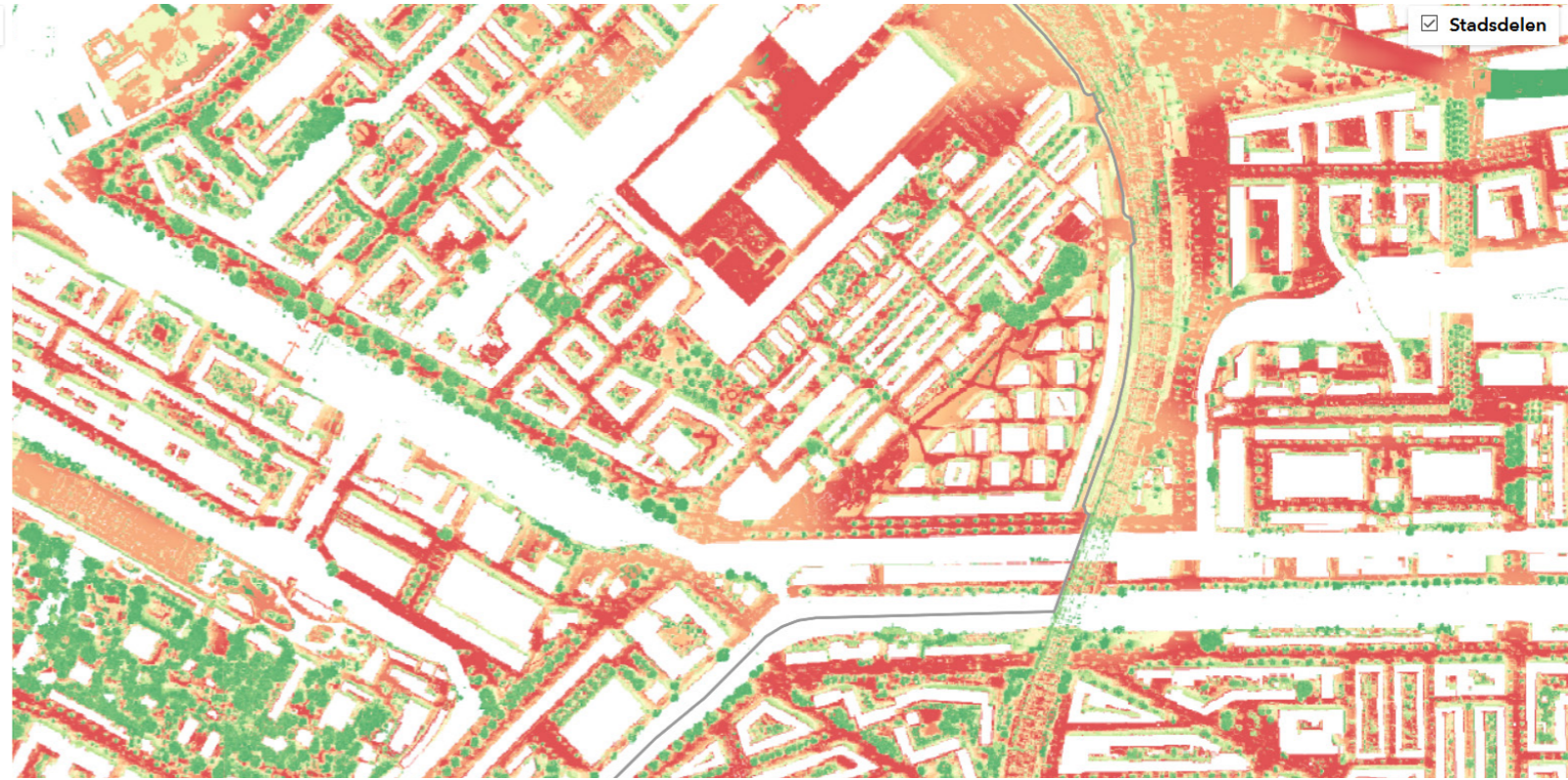
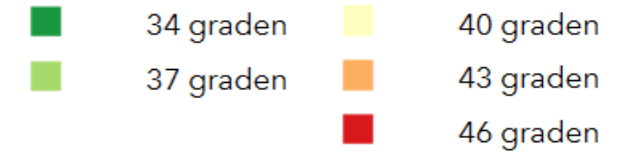
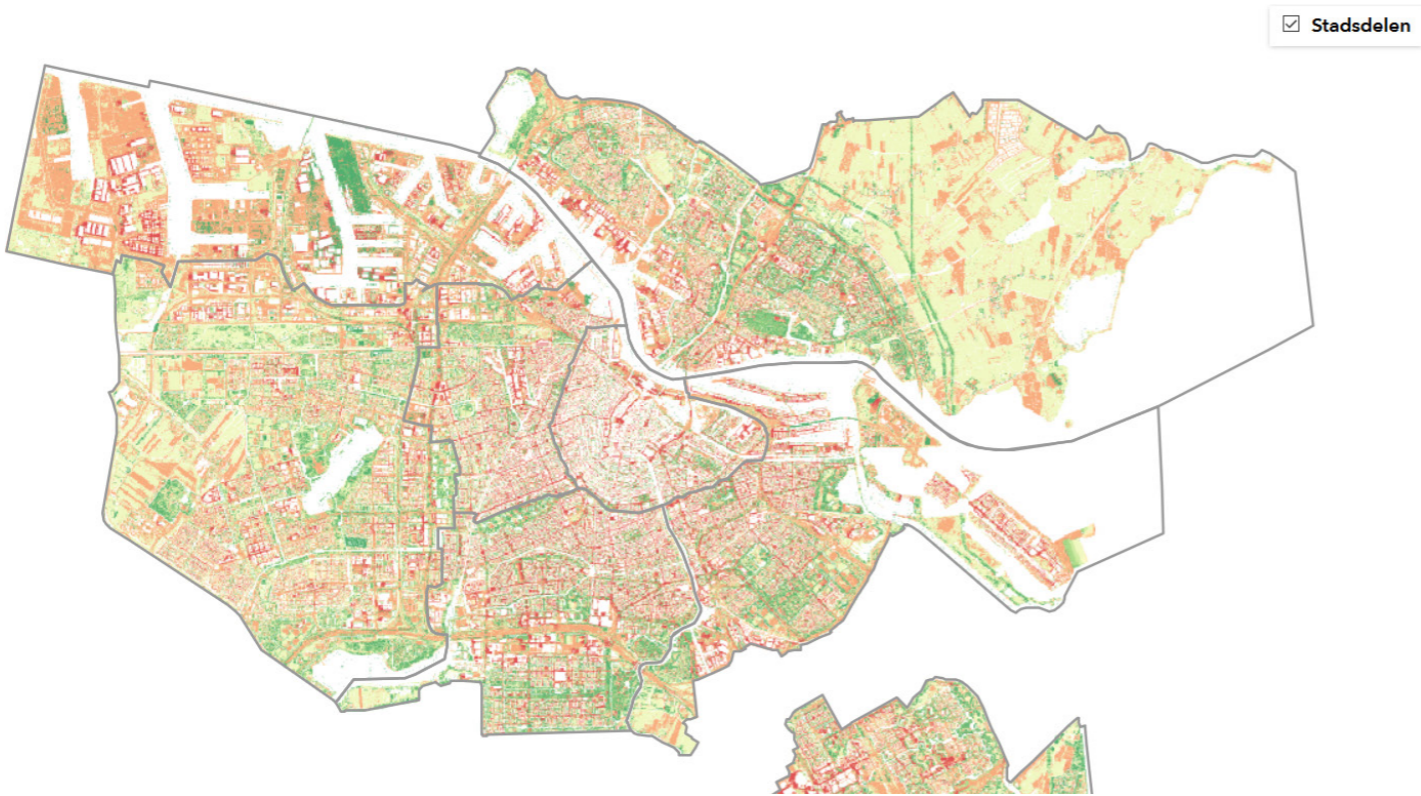
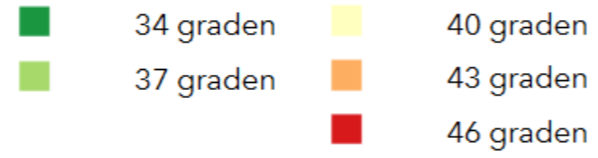

SITE ANALYSIS

CLIMATE

To summarize this chapter's graphs that are to be followed in pin points:

- Temperature in this area rises the most during July and August. In January and February it gets the coldest.
- Rainfall in July is the highest as it reaches 58.6 millimeters.
- As summer starts, days get longer and nights shorten, in June there is 16 hours of daylight on the site.

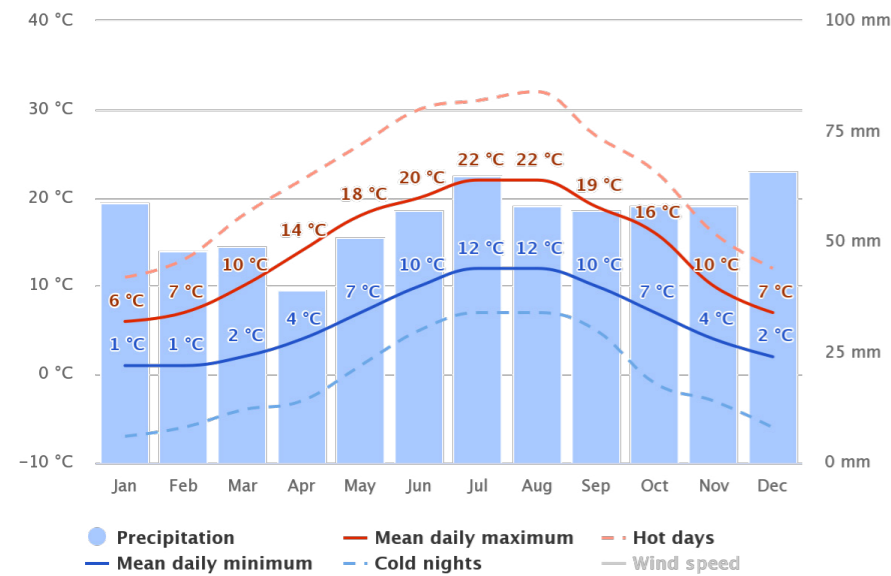

The (red line) demonstrates the most extreme temperature of a normal day for consistently for Amsterdam. Similarly (blue line) demonstrates the lowest temperature. Hot days and cold evenings (dashed red and blue lines) demonstrate the normal of the most sweltering day and coldest night of every long stretch of the most recent 30 years.

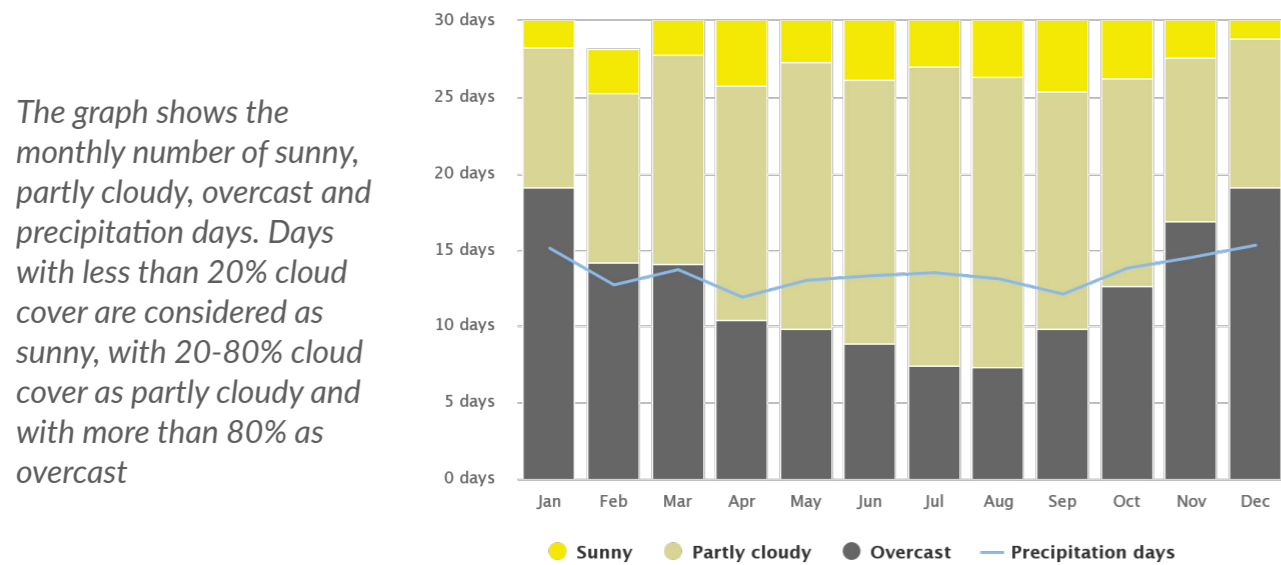

The graph shows the monthly number of sunny, partly cloudy, overcast and precipitation days. Days with less than 20% cloud cover are considered as sunny, with 20-80% cloud cover as partly cloudy and with more than 80% as overcast

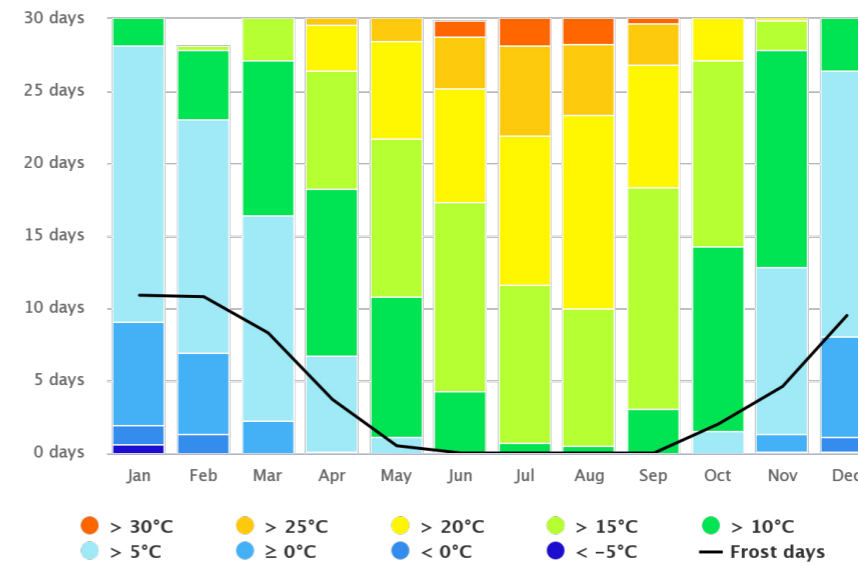

The diagram on the left illustrates (maximum temperatures) showing how many days per month reaches a certain temperature.

The (precipitation amount) diagram for Amsterdam shows on how many days per month, certain precipitation amounts are reached. In tropical and monsoon climates, the amounts may be underestimated, it can be seen here that Amsterdam is mostly a dry city (black line) snowy days.

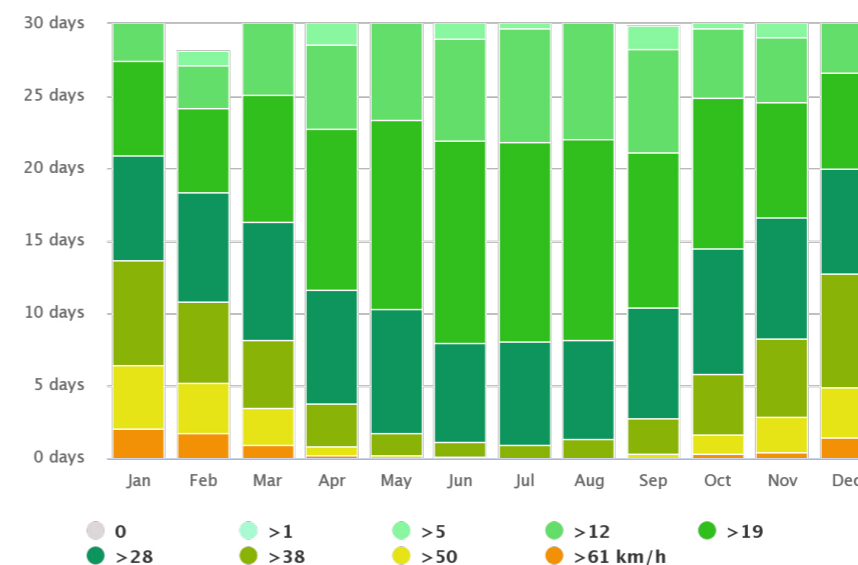
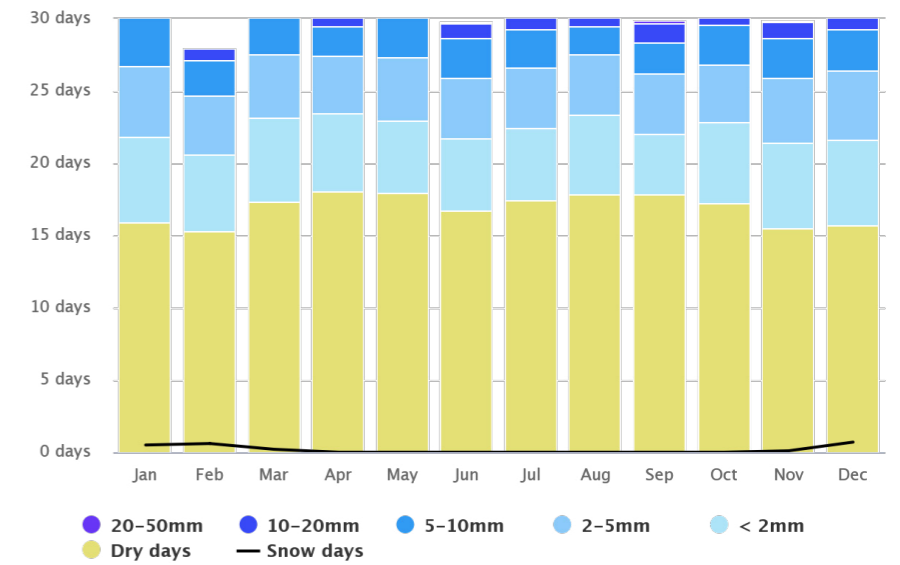

The diagram shows the days per month, during which the wind reaches a certain speed in Amsterdam.

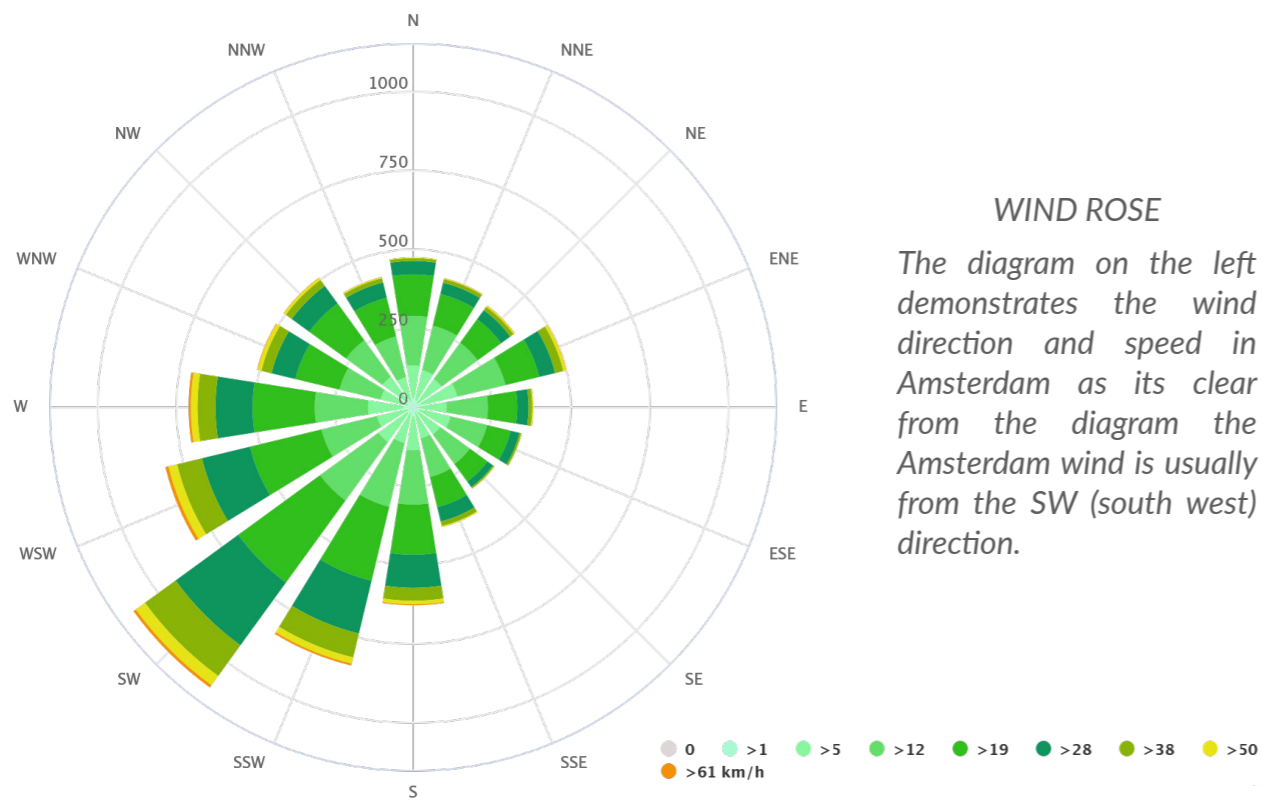

SUN DIAGRAMS:

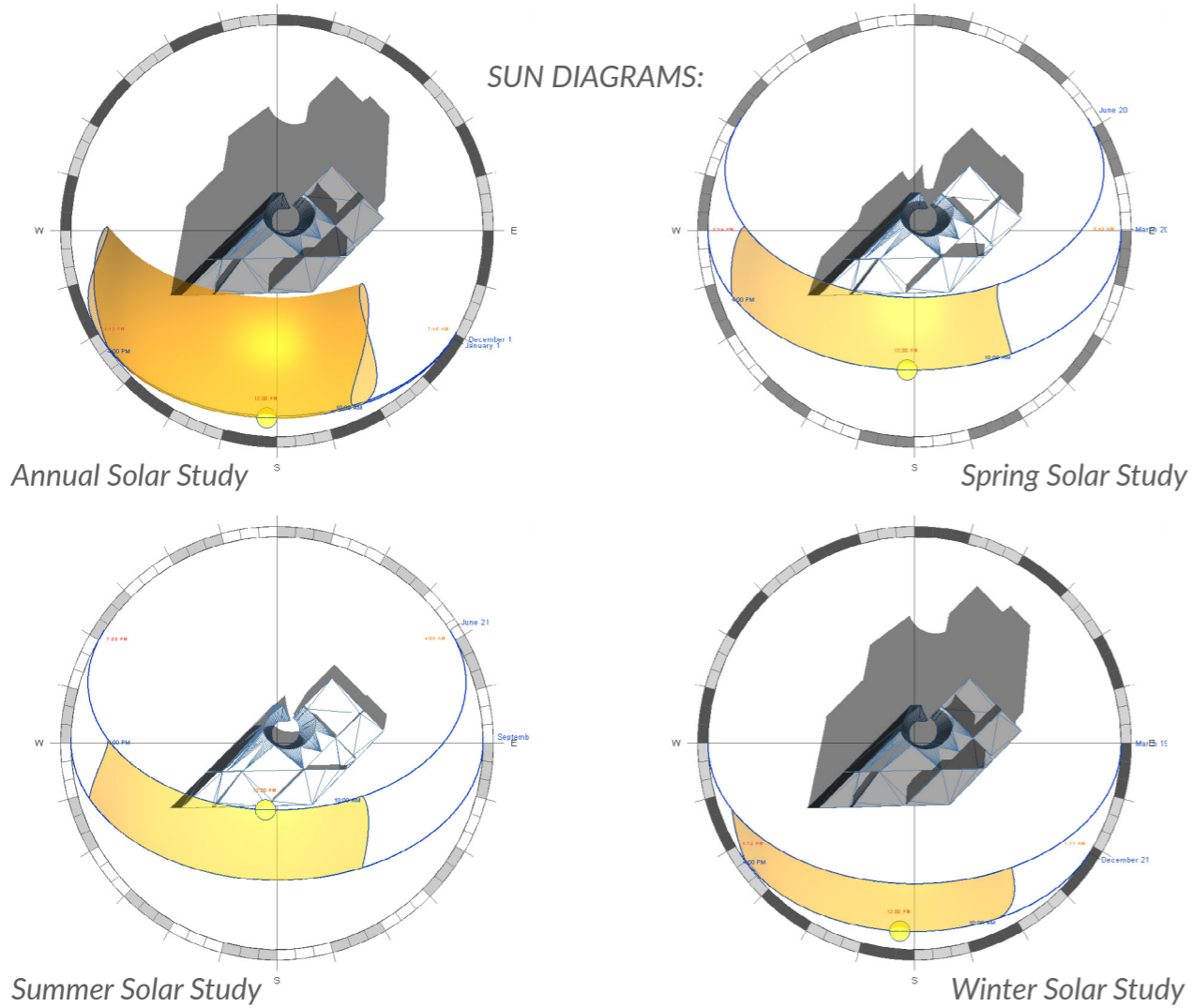

AMSTERDAM AP SCHIPH 52.30°N / 4.77°E (-4m asl)
Distance from Amsterdam (13m asl): 12 km

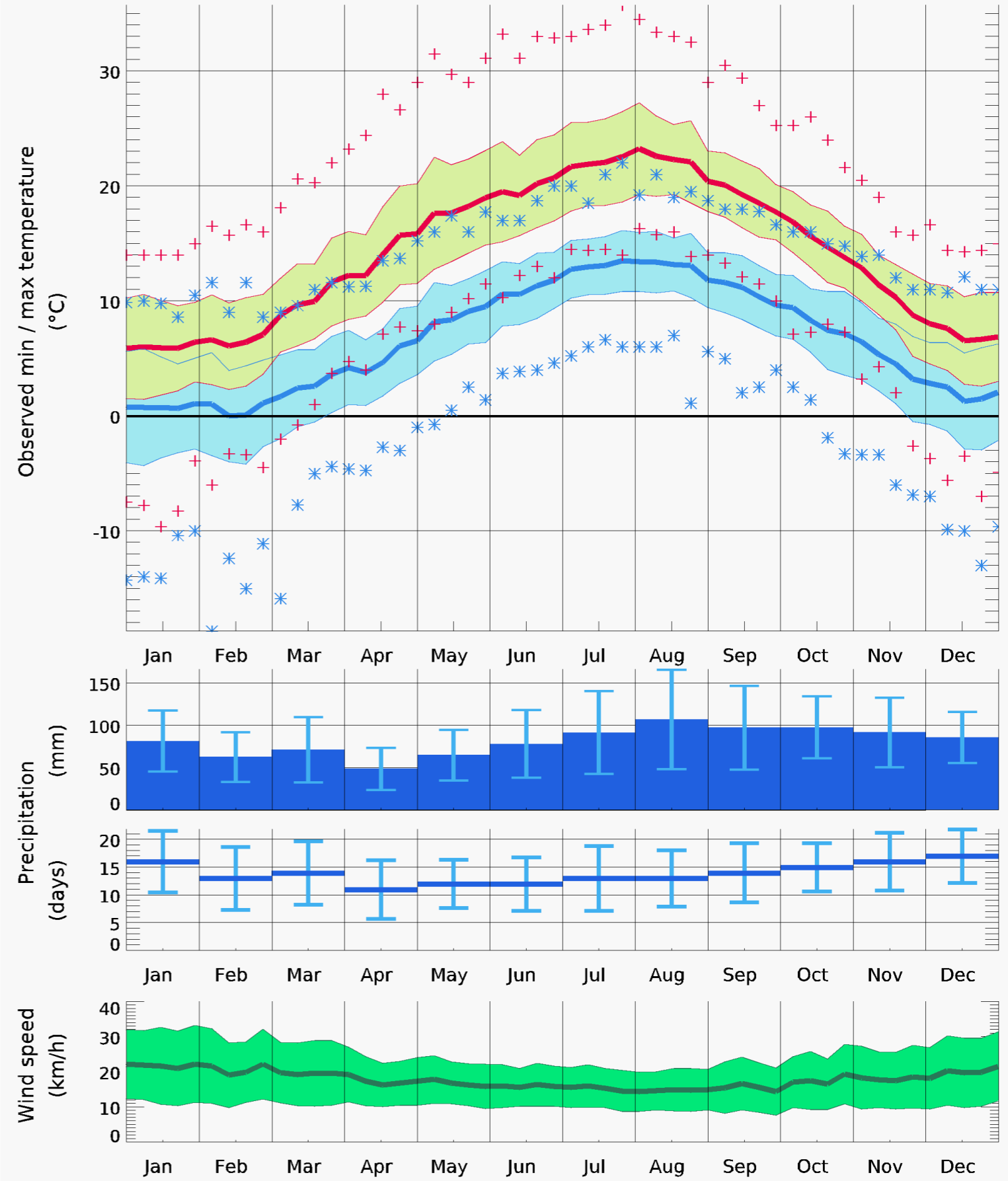

SITE ANALYSIS

SOIL PROPERTIES

Soil originating from Czaar Peterbuurt may not be applied elsewhere without research. As a party inspection shows that the land nevertheless complies with the area-specific standard of the application location, or with the generic assessment framework in an application area with generic policy, then application is still Allowed.

Land to be used within this zone must comply with the area-specific application requirements Land can be used freely here.

Land from other sub-areas of Amsterdam, or from outside of Amsterdam, may be applied if one inspection or another environmental health certificate shows that the soil complies with the area-specific application requirements. When using the soil quality map as a means of proof, the application matrix are consulted on whether application is applicable

Applying land within this highly polluted zone is seen as a „remediation operation” that must be tested against the Soil Protection Act. A remediation plan or BUS report may be necessary to be.

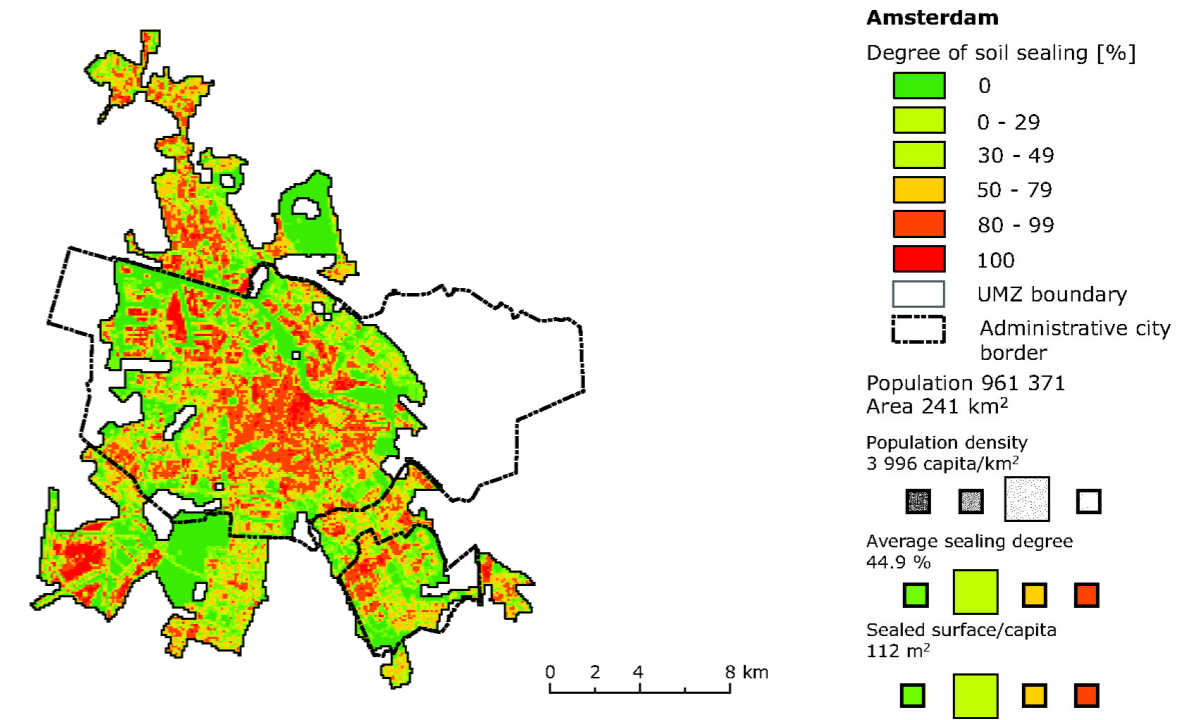
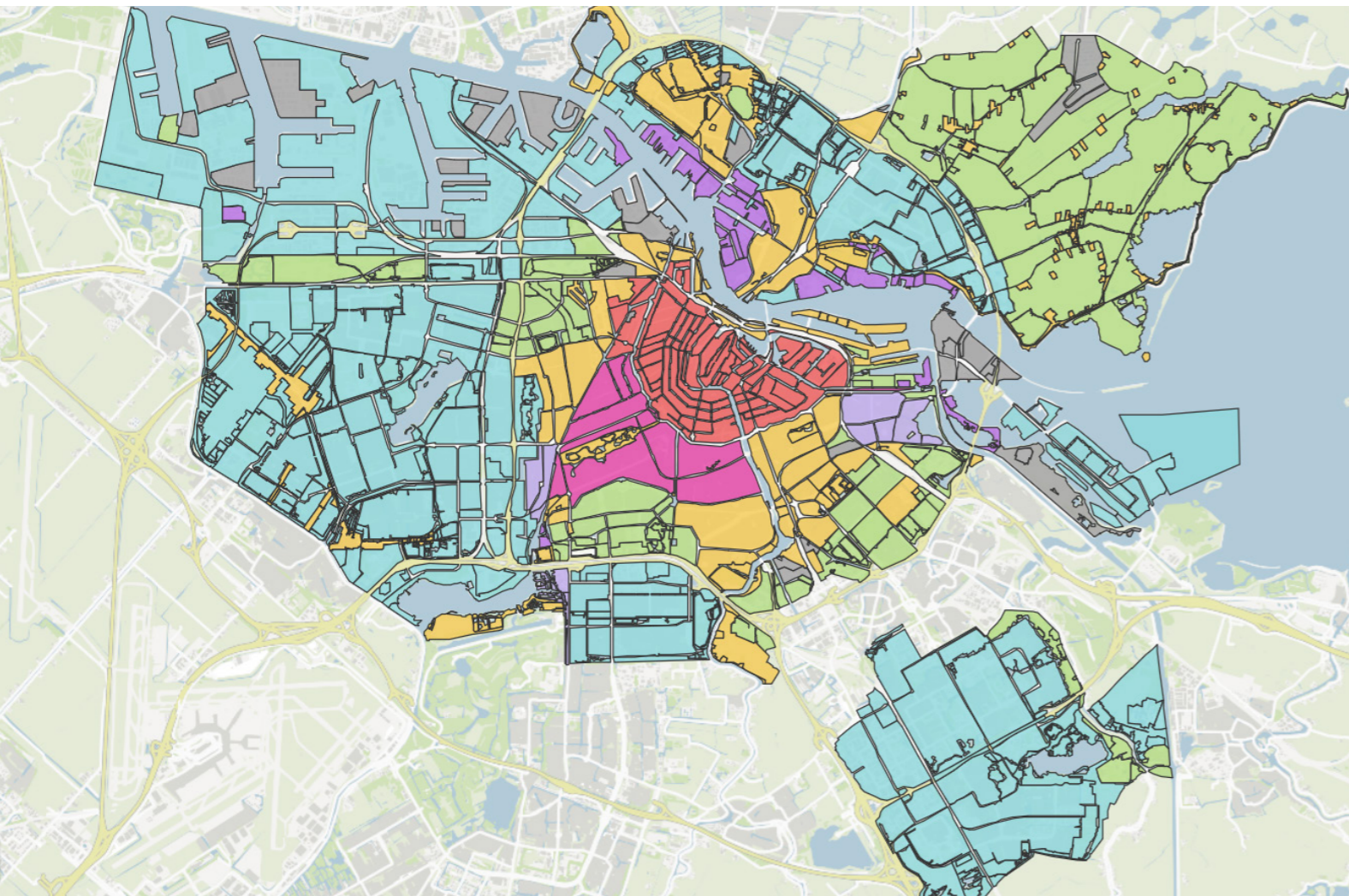

All brownfield sites with acceptable soil pollution concentrations. For both maps, red colours indicate polluted areas and green areas are usable for UA.

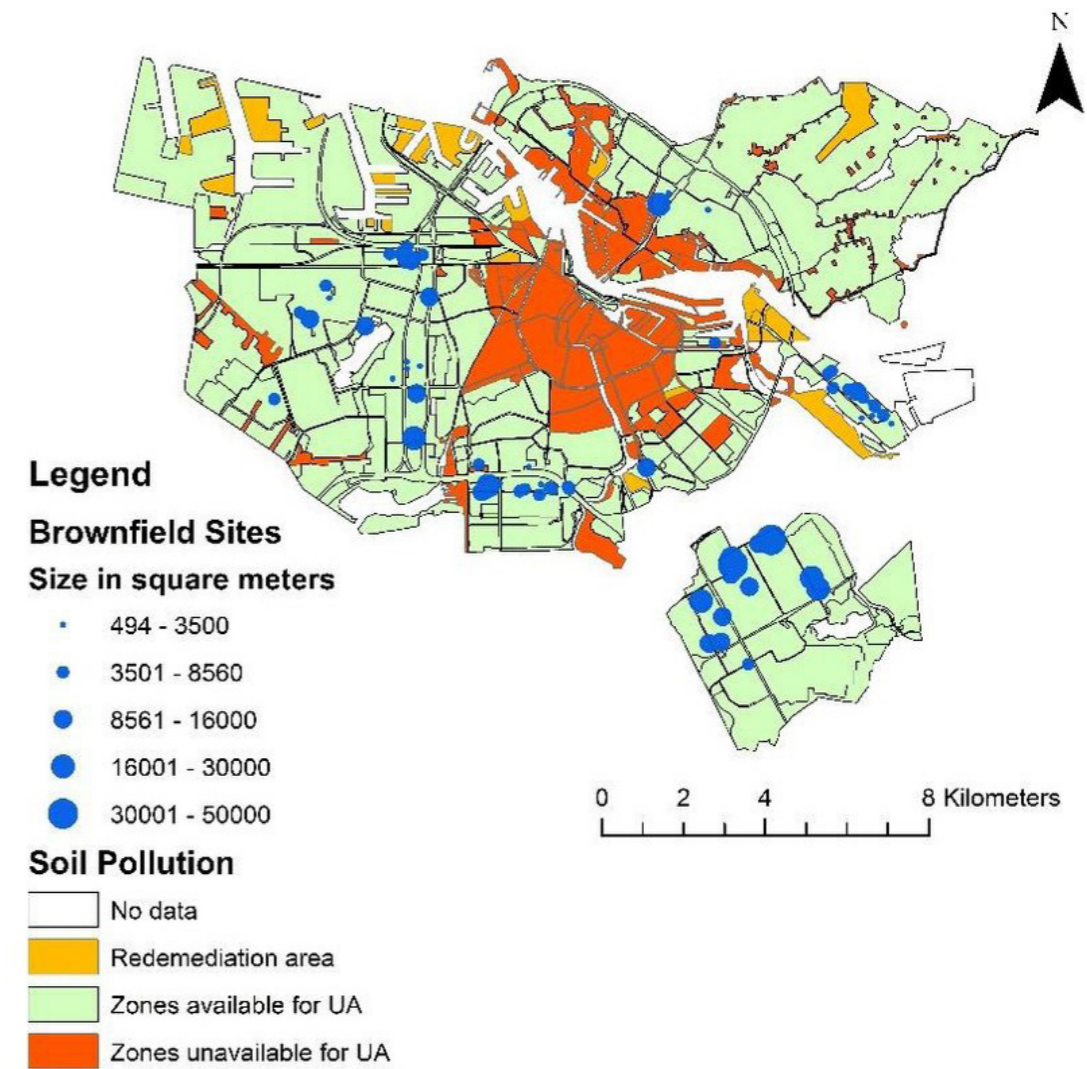

ICH SCOPE OF STUDY

QUESTIONS TO INVESTIGATE THROUGH DESIGN

1. HOW WOULD the concept behind ICH design CONTRIBUTE TO THE COMMUNITY?
2. How is ICH design responding to the context of Amsterdam?
3. Countless nationalities and cultures get represented through international students. What makes ICH design universally applicable and yet make it feel belonged to locals?
4. The community center intends to create avenues for international students to work part-time and earn. How is ICH design proposing that?
5. What are the programmatic features of ICH design?

GOALS

1. Revolve the design around the local community and have them as the focal point, as it is very important to have create a building that feels comfortable and welcoming with a local cordiality that gives the proper background to the the adjacent park and fosters stronger connections to the canal in front.
2. Create familiar and community friendly shapes that regard the customary norms of the local urban style, and create a physical form that marks a sign of a contemporary gate to Funenpark.
3. Design spaces that associates the internatioanl students with the locals, through open offices, for example, a little library, a cafe/startup restaurants, exhibittion space, and a little theater/event hall. The aim is to associate various types of individuals with the sutdents: the elderly, the young, and children, so as to make an enthusiastic territory where maximum livability is aimed for.
4. ICH to become the acknowledgment and the physical realization of an intense new vision that brings its numerous local gatherings together in a warm grasp.
5. Identity matters inside any public/comunity venture; to acheive this, ICH aims to comprehend the individuals who live, work and participate in that condition. The general motivation for the public venue originated from the remarkable scene of Amsterdam, the tolerant, variant town and the energetic nearby network.
6. Create a very integrated space to the are, by seismically bonding the structure in a thoughtful and subtle way while holding the existing legacy characteristics by refining the section grouping.
7. Design a structure that is deliberately situated at the section point to the area/park, filling in as a conspicuous landmark for regular users and visitors the same. Make everything about transparency and not disconnection, by invigorating urban uprightness. This would make ICH innovative within the Dutch settings.
8. ICH design aims to create stories and nerratives for the user where "The journey is more important than the destination" hence central meeting ground is designed completely open to the public in an open air scenery, as well as completely open floor layouts.
9. ICH aims the utilization of a material, that change with the progression of time, to communicate "Time" in a region where data and conditions are ever quickly evolving. This little bit of design is an exploratory dimension of the general topic of "light" and "time."
10. Plan treatment of the connection between the "invisible" and the „visible“, the "imperceptible" and the "unmistakable".

11. Given the remarkable site of ICH by the canal and close to the city center, the design treatment of the connection among design and nature is essential to the redemption of their natural joining.
12. Because of the novel idea of the service program by ICH, the plan needs to guarantee guests from all bearings can arrive at the serving spaces swiftly; and simultaneously, it needs to accommodate users, and visitors who can't or don't want to get to enter into the serving facilities at ICH, the site aims to provide momentarily comfortabl settings and used design for view, accessibility and resting.
13. The rich layering of ICH's concept resembles the example and rhythm of the Amsterdam, mirroring the agreeable qualities of multiculturalism and multi-ethnic combination throughout the entire existence of the Netherlands.
14. The site has a solid visual bonding to the Funnenpark, a significant course into the community center. The utilization of semi-straightforward hued cladding would permits the public venue to be normally lit in the day and to give a solid unique connection in the area. At night, the utilization of lighting would permit ICH to turn into the ,reference point' inside the network.
15. In an excellent green area, encompassed by low-ascent apartments, ICH is structured as the social heart for the community of Czaar Peterbuurt and Amsterdam. It is a spot for everybody; a spot to meet for business, training, and culture – a multifunctional focus where you can locate a decent Harmony between the intensity of the group and individual articulation.
16. Not a social community concentrated on those capacities, but instead to plan a spot for social association, center around individuals. Have spaces for all guests, big and little, the youth and elderly. Counting spots to see each other's exercises, empowering interest and invigorating experiences and coordinated effort.
17. The thought is that the users will experience others, so they don't feel alone in a large building, especially if they were utilized to their own little accomodation before. There are huge gathering places for festivities when a significant event or special time of the year, just as comfortable spots to peruse a book peacefully or play a round of cards with a couple of companions.
18. ICH is to be carefully mixed into the encompassing park and urban texture. As the structure is isolated into littler volumes – each marginally moved according to the next – the gathering shows up little notwithstanding its driven program of exercises. This makes a structure Harmonous with the encompassing texture and condition.
19. The central space flawlessly associates all the various offices, visitors, and users. Around this central zone, all the indoor and outdoor activities are composed and unmistakable when you show up.
20. Through cautious utilization of materials, mood and examples, the huge structure volumes are cut back to a human scale.
21. Each individuel space offers an alternate character in tallness, shape and environment.
22. The venture ICH is about the association of individuals and society. Presented as another community center in Czaar Peterbuurt.
23. Create a highly efficient project, through the use of latest energy efficient technologies. Shrewd steering in the stopping territory to restrain the unnecessary discharge of fumes exhaust, and the vitality proficient LED lighting framework possibly turns on when there is movement. Maintainable visitors can charge their vehicles at one of the charging spots, where nature is centered at ICH.
24. ICH to be a desert spring for the visitors and users of the bustling city of Amsterdam and explicitly the network and community of Czaar Peterbuurt.
25. ICH should feature a solid public capacity. Beside the training and enterprise, ICH is likewise utilized as a public venue or meeting area.
26. The objective is to make a connection with the available open space in Czaar Peterbuurt. A powerful house praising the cozy relationship to the canals and the conventions of the fishermen, presently on one hand among students and the community and tight clamp versa, and then again among the community itself as well.
27. Making a proposal that excells in the best path by joining the desire of interesting, experimental and innovative design and architecture with an elevated level of functionality and the aim of making a frame, supporting the community and making another fellowship between everybody included.
28. ICH to be assessed to adjust robust functionality, rawness of the community, and aesthetics in a wonderful mix explicitly made for Czaar Peterbuurt and Amsterdam, the urban setting and the extreme givens of the atmosphere, and consequently is assessed as meeting the desires of the competition's program in a excellent manner.

ICH SCOPE OF STUDY

OBJECTIVES



Glocal

Countless nationalities present. Design should be diverse and yet belong to the city

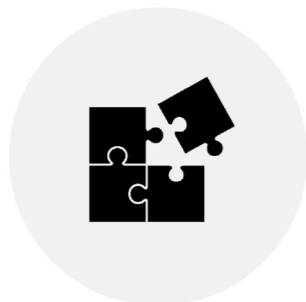

Productivity

How can humans do more and be enabled to do more.

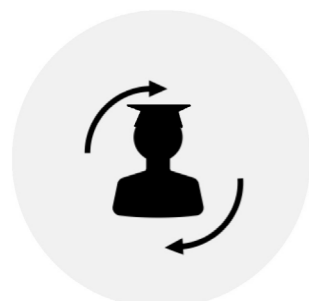

Adaptability

The students are temporary residents of city. With changing population, how does design respond to the changing needs.



Overlap

Interaction between locals and international students is critical for inclusive development

The following objectives can be a point of beginning to conceive this design. Participants can assume their own contexts and users before initiating their design process.

The community space will be a stepping stone, that facilitates smooth inclusion of international students into local fabric. Besides resourcing their needs in a foreign land, it will be a space of interaction between locals and students. An avenue to celebrate their culture, and make it familiar to the people of Amsterdam. Also a platform for students to be self sufficient by earning credit or money.

ICH SCOPE OF STUDY

PROGRAMMATIC OUTLINE



Participants can alter the area programme according to the design concept and intent. Participants don't have to necessary detail out individual spaces.

EXTENDED SITE STUDIES

SITE FEATURES (CANALS, PARKS, AND MAIN ROADS)

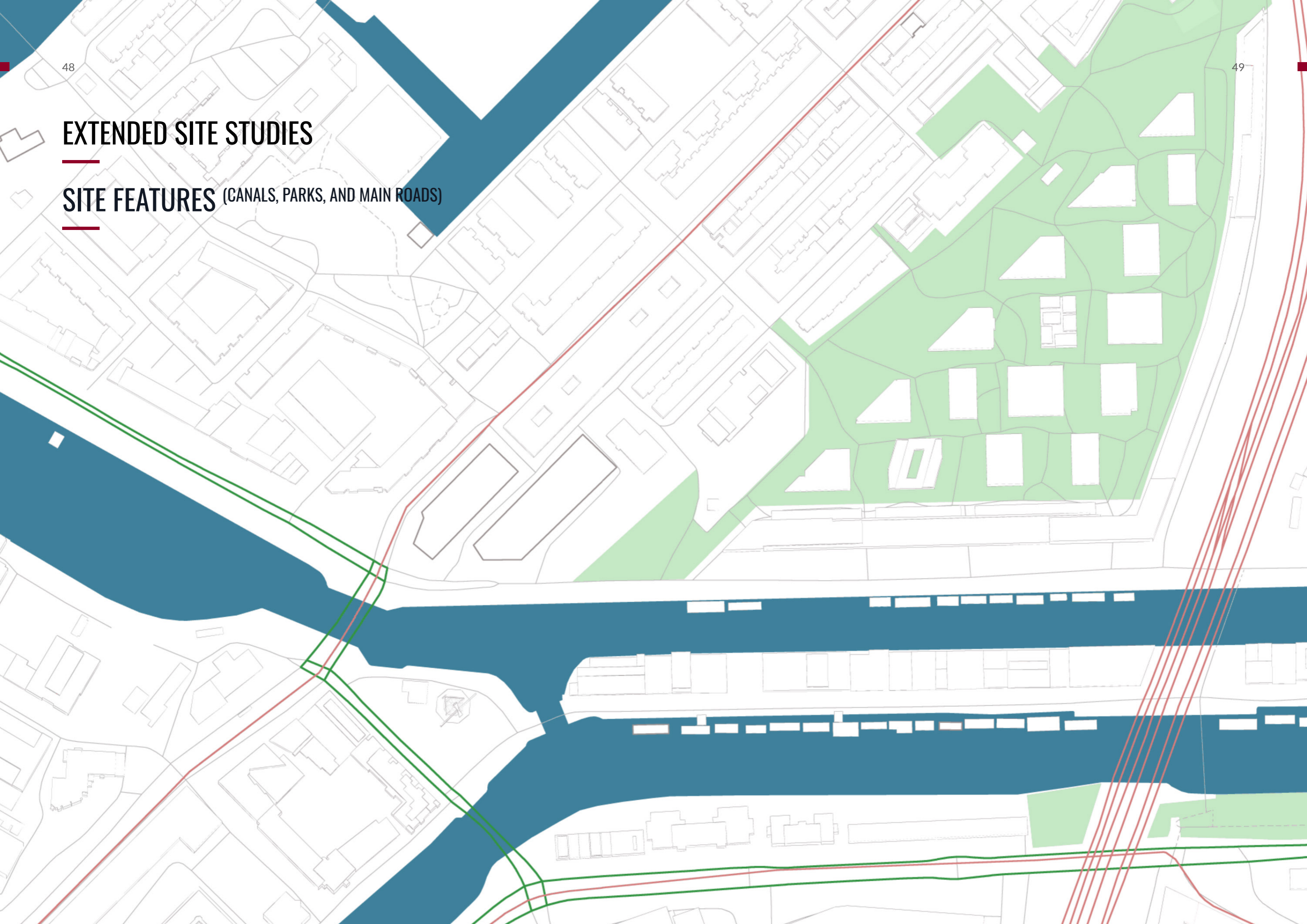

EXTENDED SITE STUDIES

STREET NETWORK



EXTENDED SITE STUDIES

ENVIRONMENT AND SURROUNDING

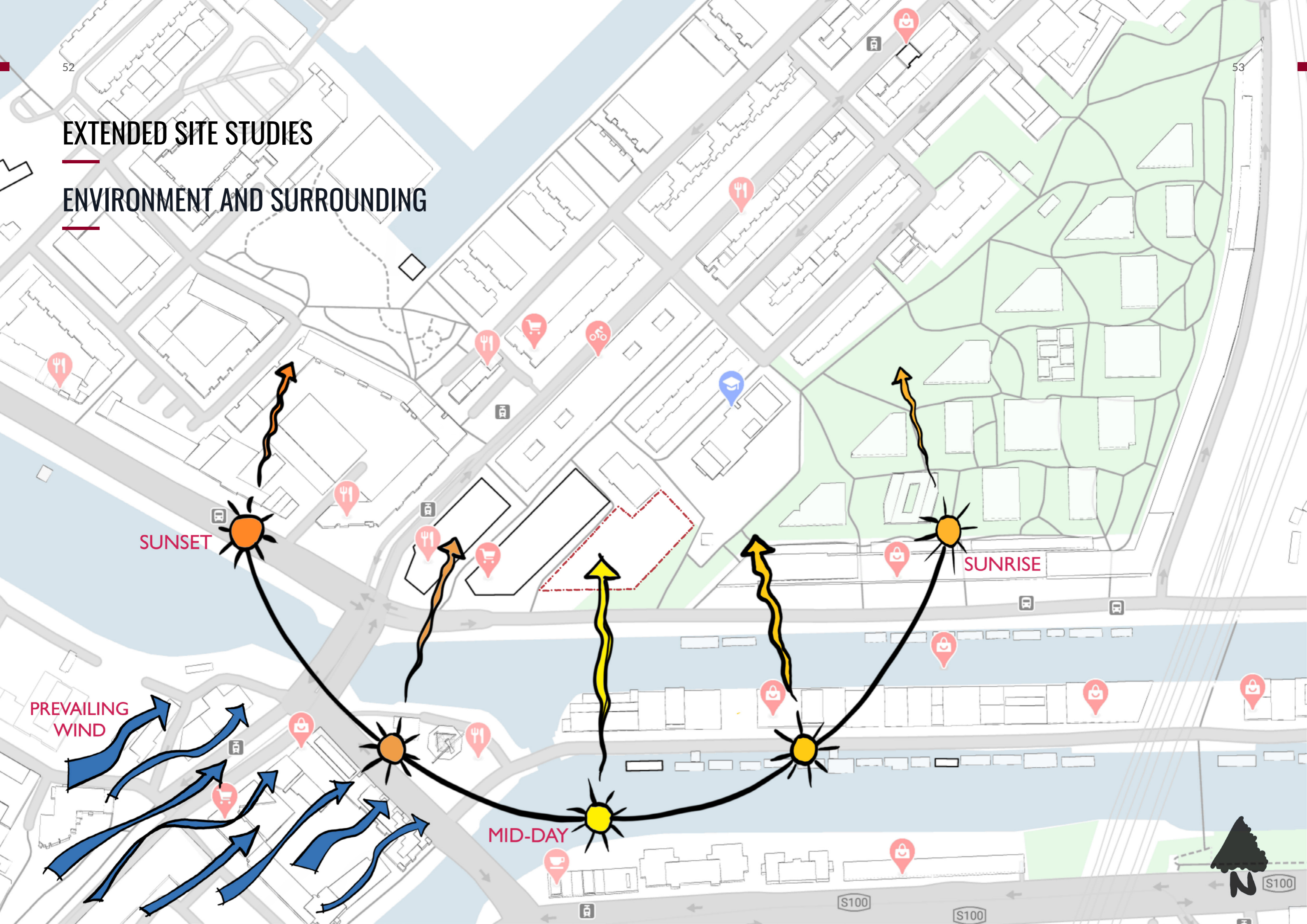

EXTENDED SITE STUDIES

ENVIRONMENT AND SURROUNDING

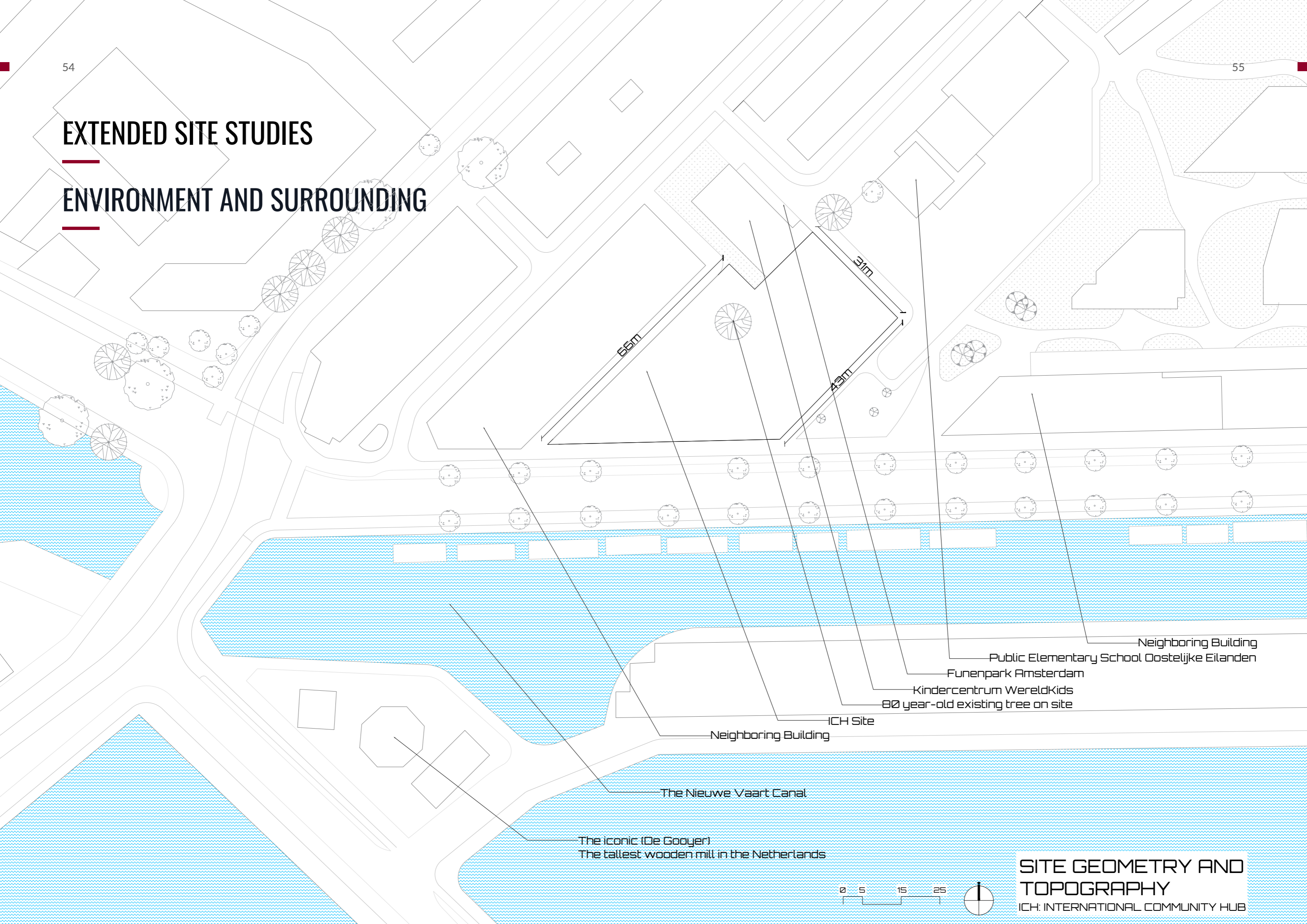

The iconic (De Gooyer)
The tallest wooden mill in the Netherlands

The Nieuwe Vaart Canal

Neighboring Building

ICH Site

80 year-old existing tree on site

Kindercentrum WereldKids

Funenpark Amsterdam

Public Elementary School Oostelijke Eilanden

Neighboring Building



SITE GEOMETRY AND TOPOGRAPHY

ICH: INTERNATIONAL COMMUNITY HUB

FUNCTIONAL ANALYSIS OF ICH

Gross Area is **2500 sqm**

List of the functional program:

Public Spaces

1. Central Hub (Completely outdoor and Public)^A
2. Lobby + Lounge/Cafe Seating

Public Service Spaces

3. Kitchenette + Pantry
4. Kitchen Receiving Area
5. Public Toilets
6. Vending Machines + Arcades

Large Group Activities and Spaces

7. Central Cultural Platform
8. Interactive Space/Exhibition Area
9. Unisex Toilet for the Disabled
10. Ladies Toilets
11. Gents Toilets
12. Storage, dressing, and lodging

Small Group Activities and Spaces

13. Educational Private Class
14. Lecture Hall
15. Speciality Lounge (Theme) + Pantry
16. Library + Carrels
17. Multi-Purpose Hall (Small)
18. Multi-Purpose Hall (Large)
19. Indoor Entertainment Pool Billiards + Ping Pong + Interactive Arcades
20. Outdoor Multi-Purpose Area

Administrative Spaces

21. Administrative offices
22. Storage
23. Male Staff Room
(Changing Room + Lockers + Toilet + Shower)
24. Female Staff Room
(Changing Room + Lockers + Toilet + Shower)
25. ICH IT Department
26. CCTV + Control + Security Room
27. Archive

Services

28. Janitors' Closet
29. Plant Rooms
 - 29.A. Electrical Room
 - 29.B. Electrical Storage
 - 29.C. AHU
30. Ticket And Event Office
31. Management Open Plan Offices
32. Waste Disposal Room
33. Transformer + Battery Room
34. Rain Harvesting Tanks + Maintenance

A: A completely Open/Public space extends and connects the Funnenpark and the street.

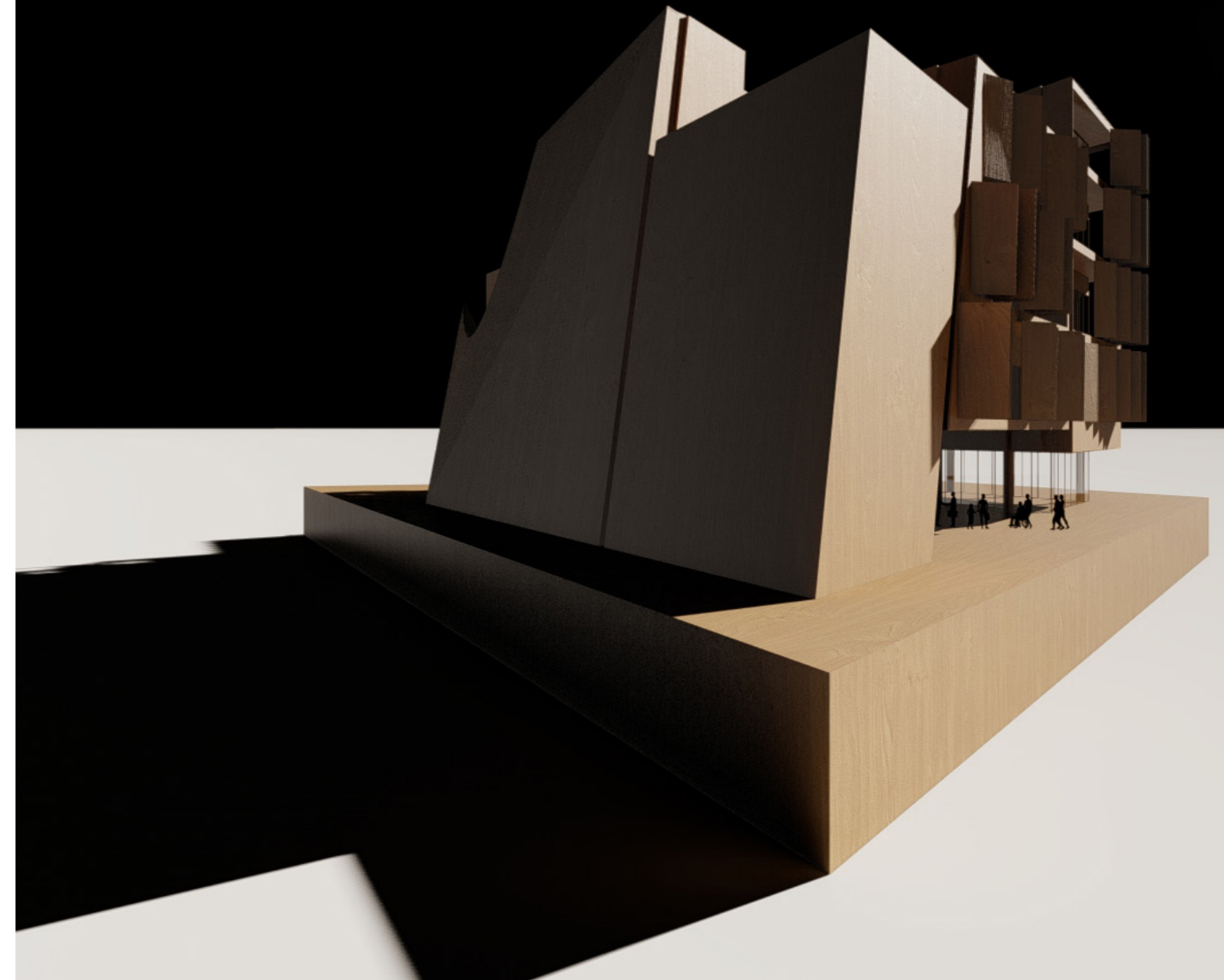

2,500

Square Meters of Pure Energy Efficiency,
User-friendly Built Environment

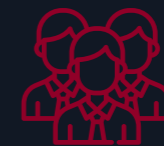

FUNCTIONAL SCHEMA

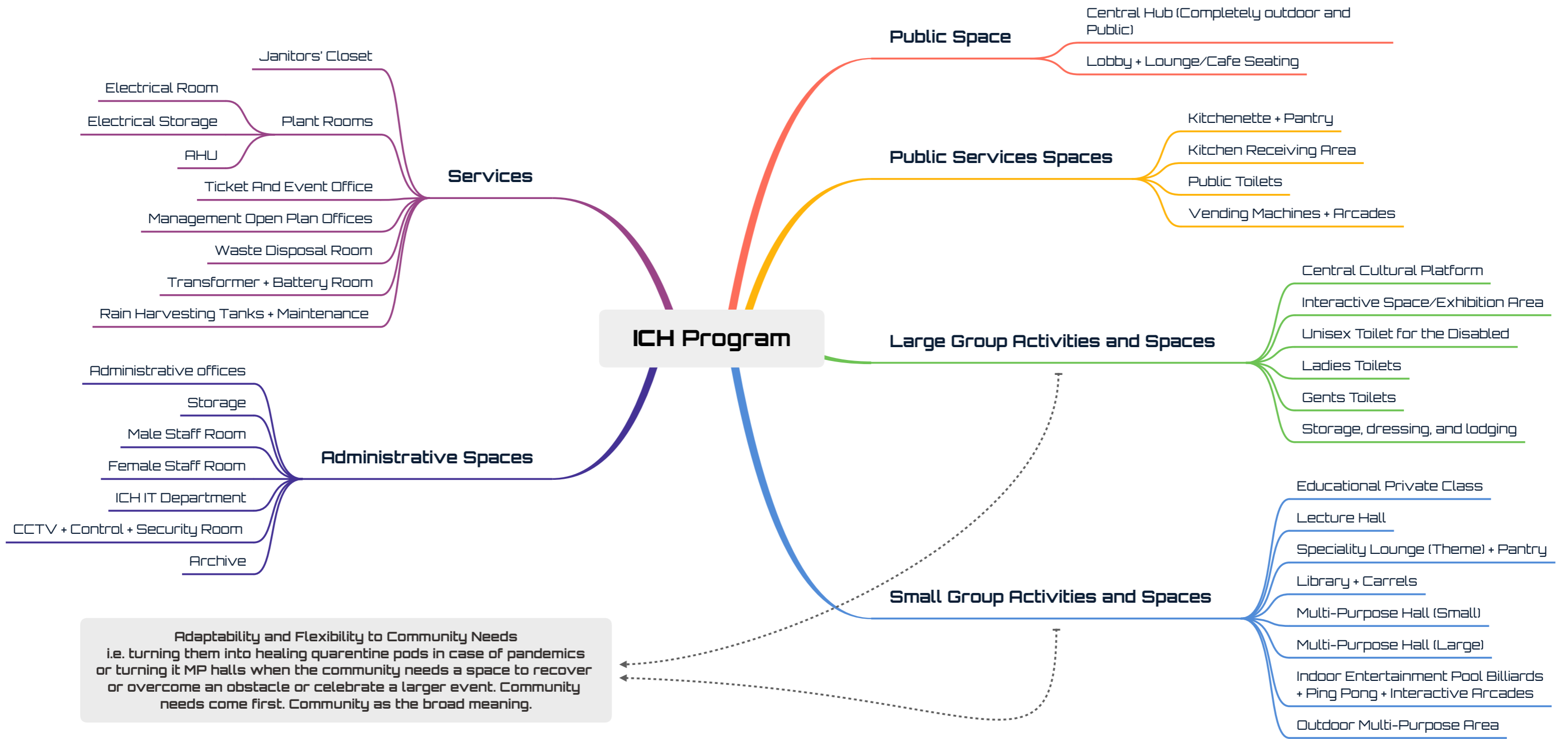

PRECEDENT STUDIES (SIMILAR PROJECTS)

MULTIFUNCTIONAL CENTER DOELUM
BY NOAHH + STUDIO NUY VAN NOORT

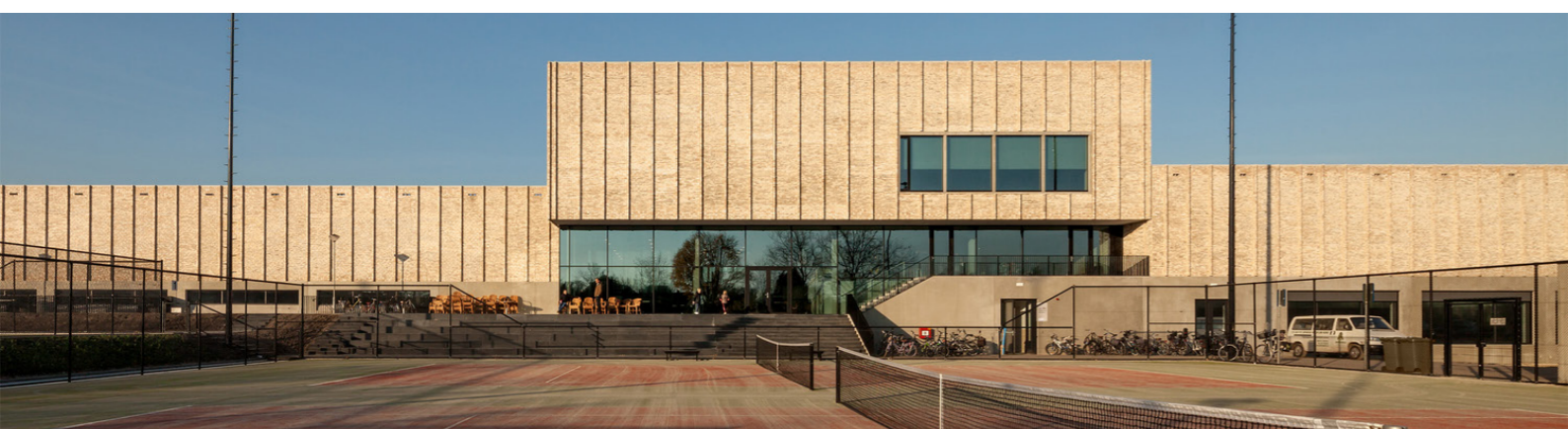

PRECEDENT STUDIES (SIMILAR PROJECTS)

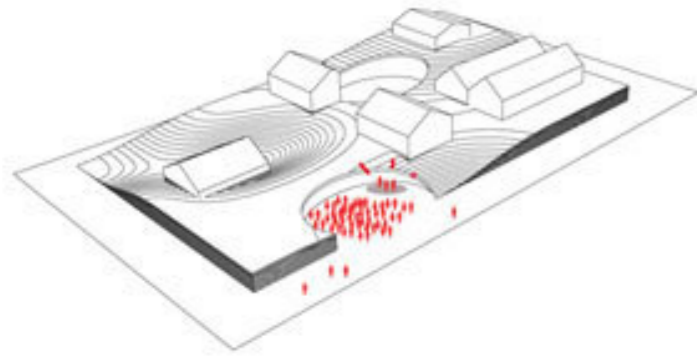

EVENEMENT PUBLIC : PIAZZA

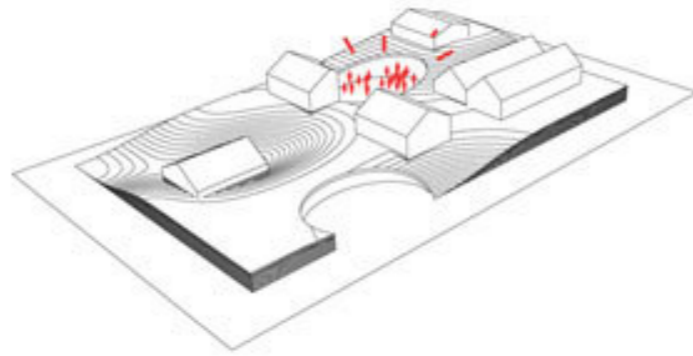

EVENEMENT PRIVE / ETUDIANT: PATIO

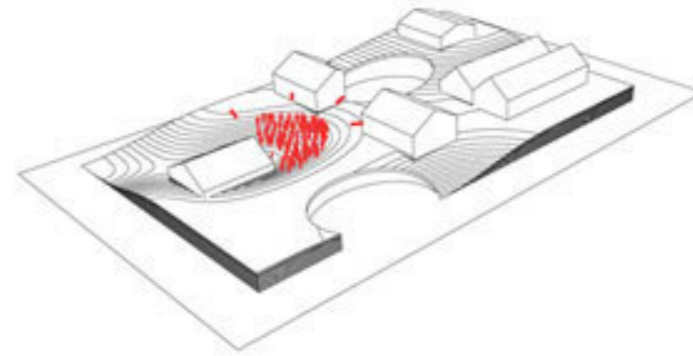

GRAND CONCERT : Jardin

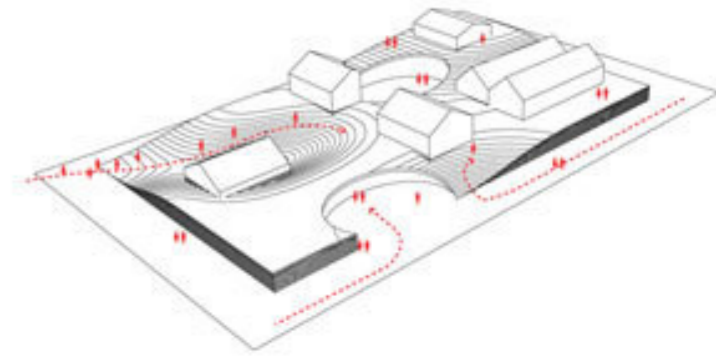

UTILISATION QUOTIDIENNE



PRECEDENT STUDIES (SIMILAR PROJECTS)

WAIHINGA MARTINBOROUGH COMMUNITY CENTRE BY WARREN AND MAHONEY

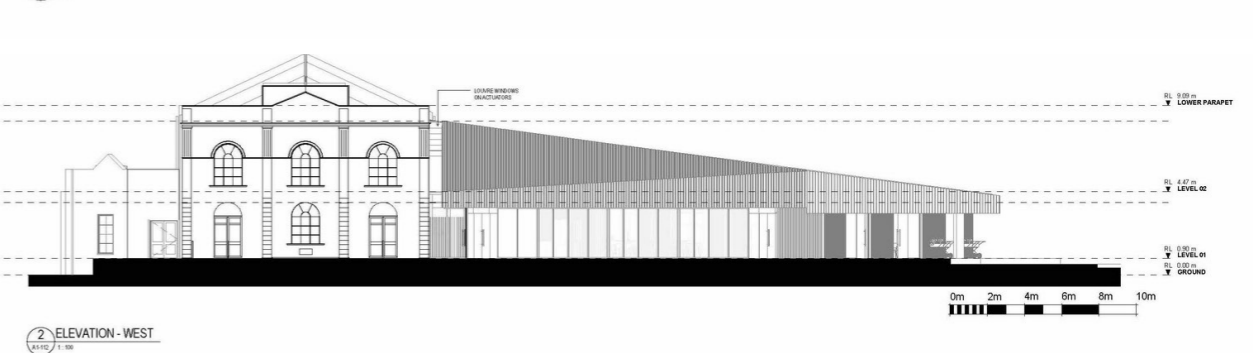
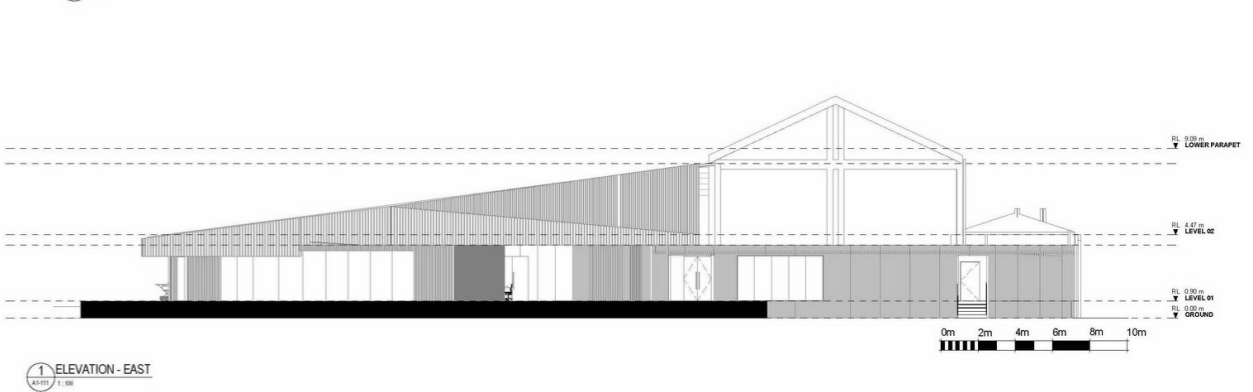
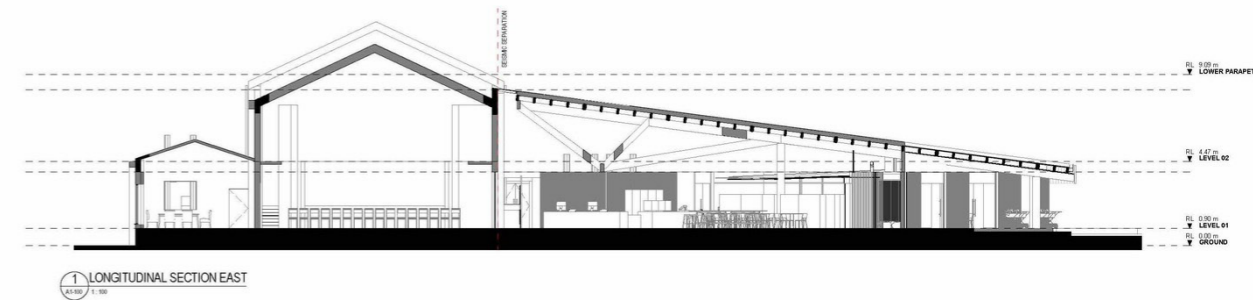
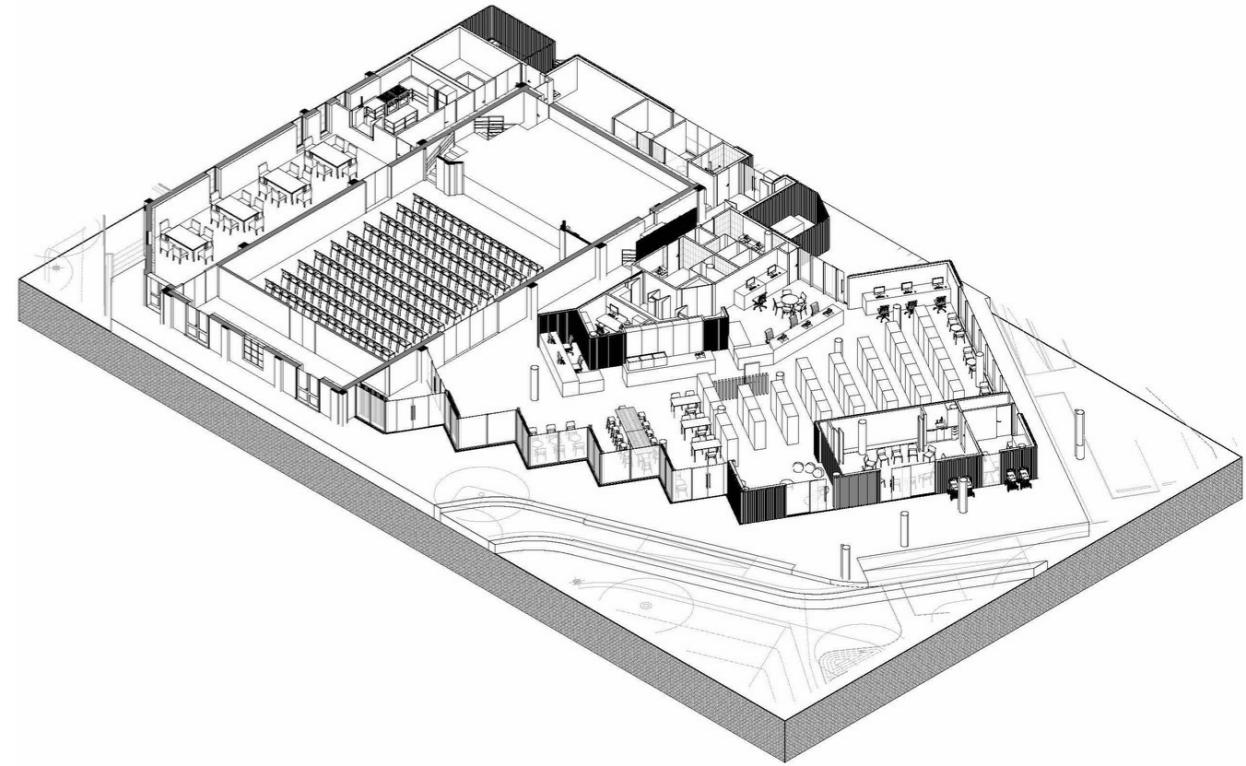
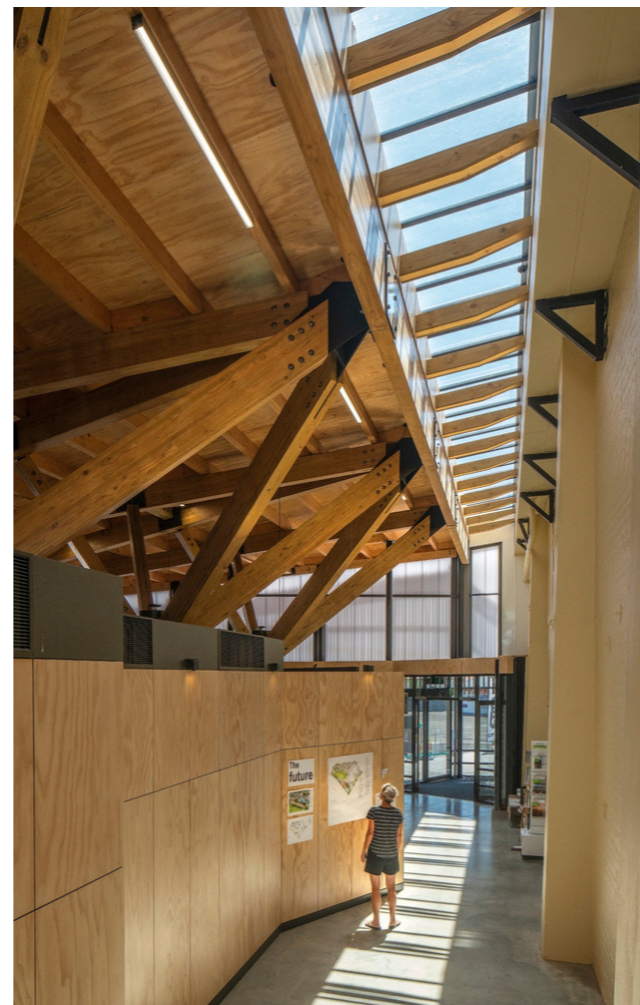

PRECEDENT STUDIES (SIMILAR PROJECTS)



THE LIGHTHOUSE YOUNG PEOPLE'S CENTRE
BY ASSOCIATED ARCHITECTS

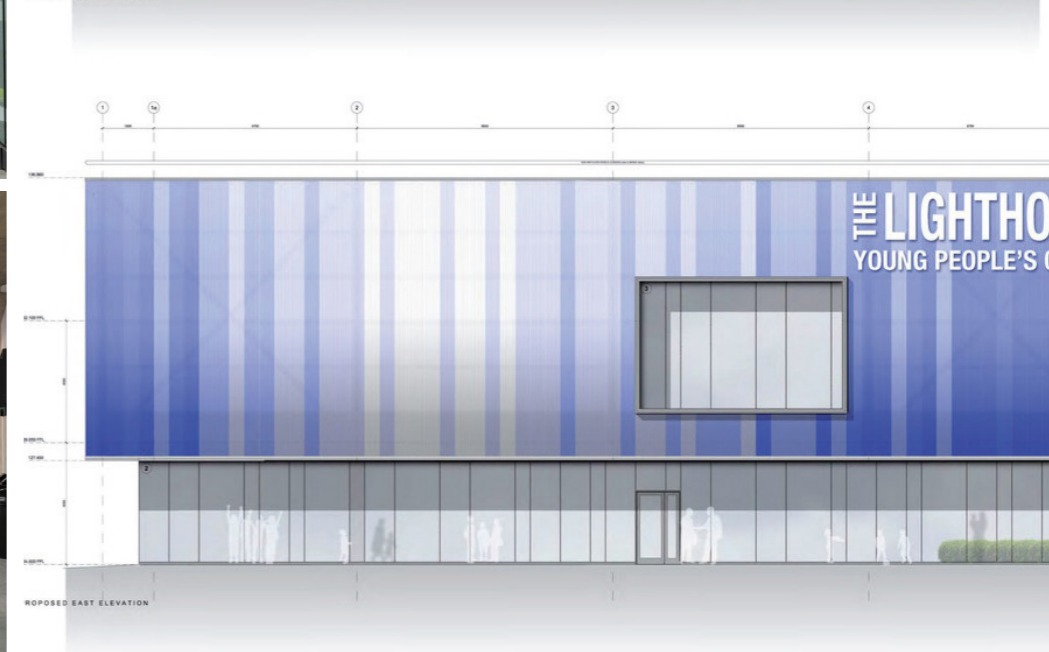

PRECEDENT STUDIES (SIMILAR PROJECTS)

MONCAYO CLUB HOUSE BY ICONICO STUDIO

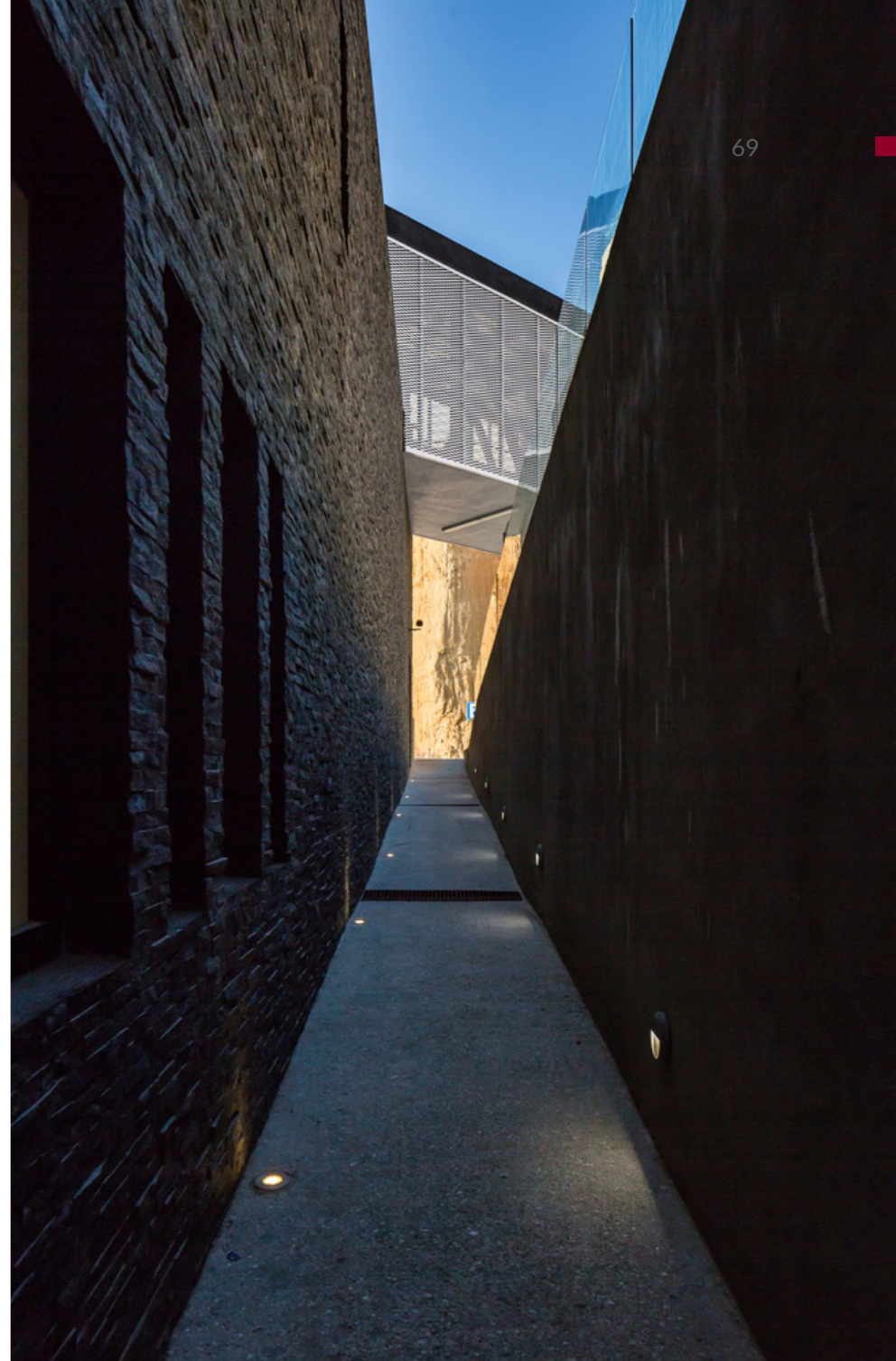

JIKKA BY ISSEI SUMA

PRECEDENT STUDIES (SIMILAR PROJECTS)

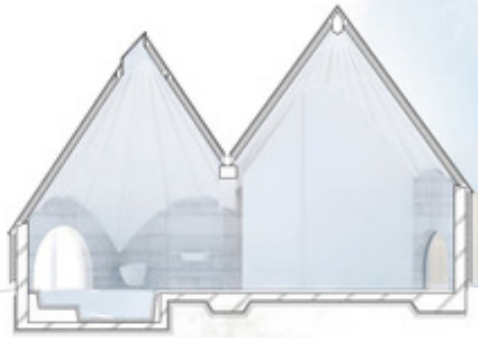

PRECEDENT STUDIES (SIMILAR PROJECTS)

THE PINCH LIBRARY AND COMMUNITY CENTER
BY JOHN LIN + OLIVIER OTTEVAERE

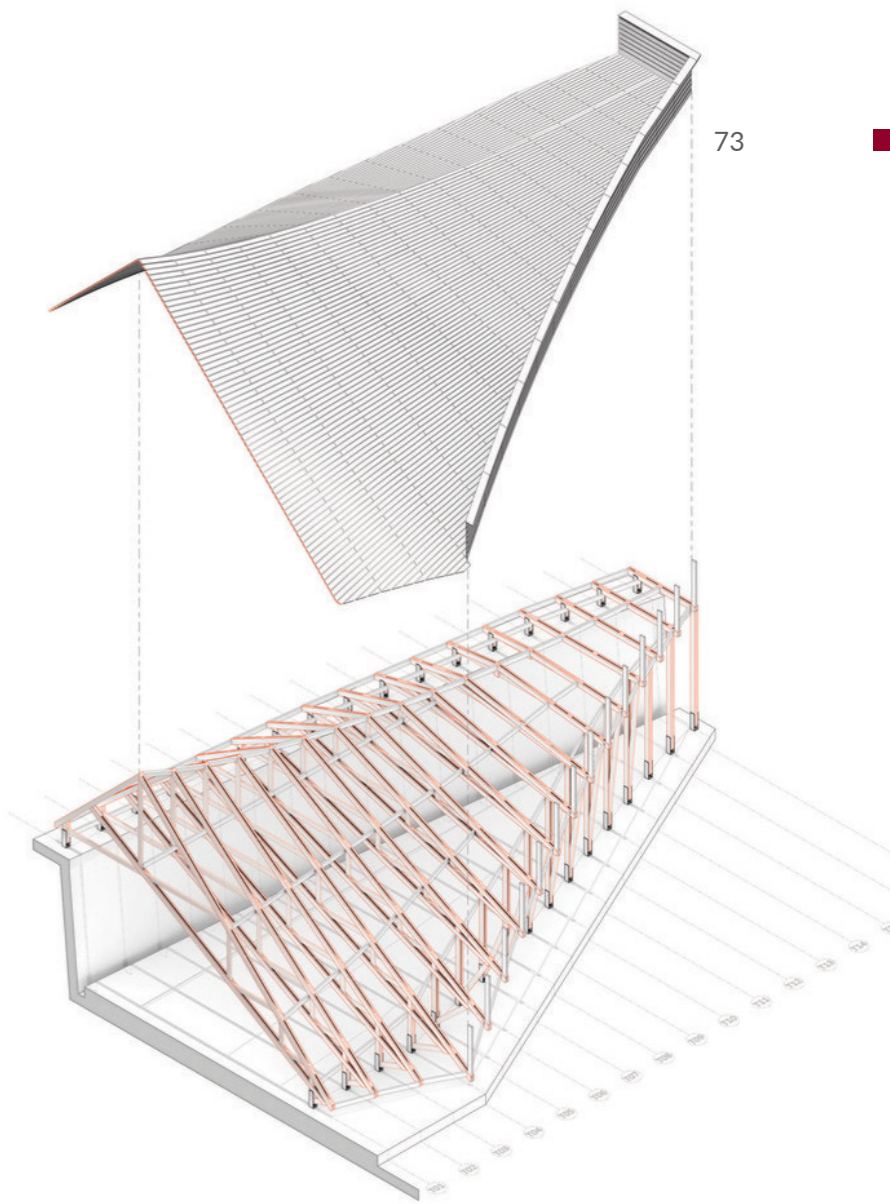

PRECEDENT STUDIES (SIMILAR PROJECTS)

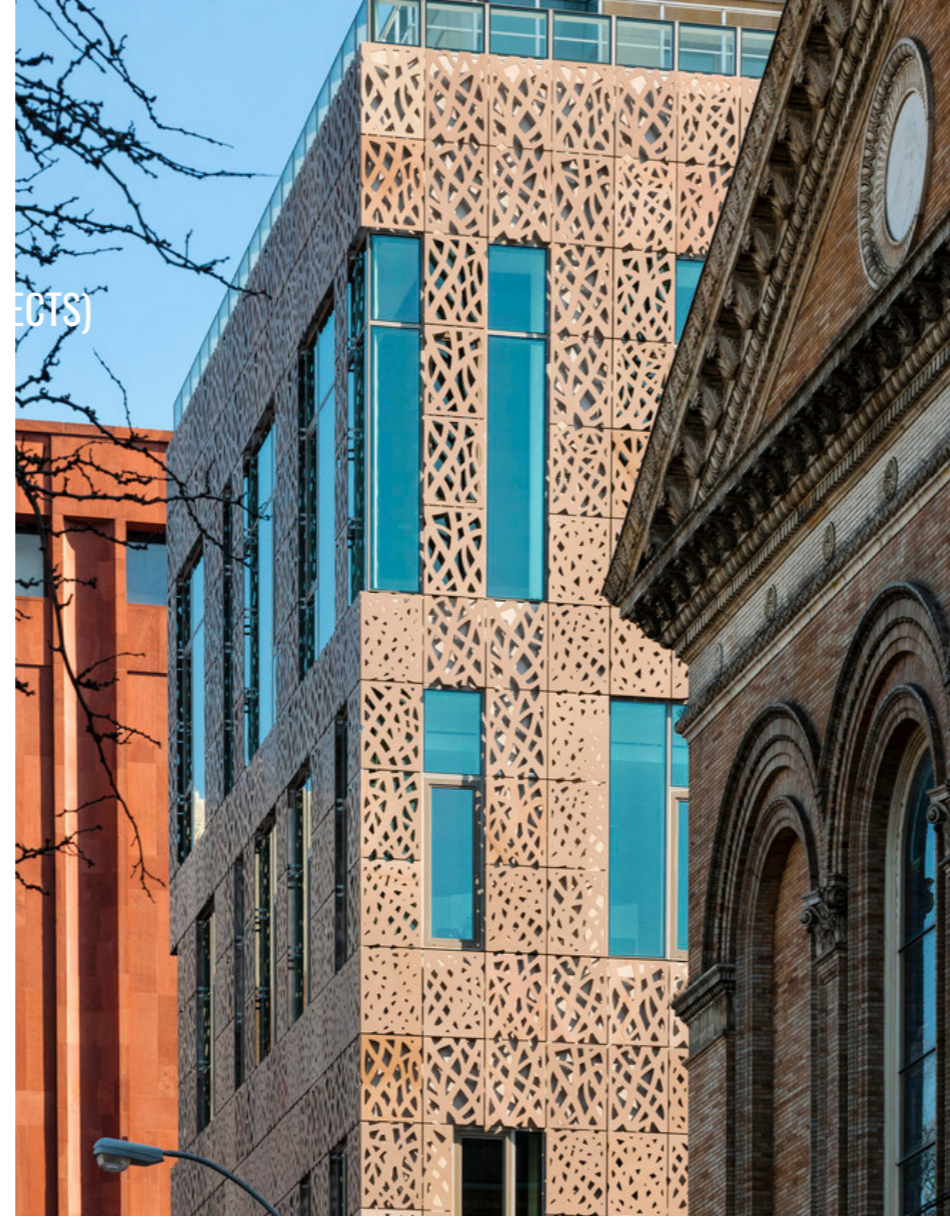

GLOBAL CENTER FOR ACADEMIC AND SPIRITUAL LIFE
BY MACHADO AND SILVETTI ASSOCIATES



PRECEDENT STUDIES (SIMILAR PROJECTS)

MARITIME CENTER IN DENMARK BY WERK + SNØHETTA

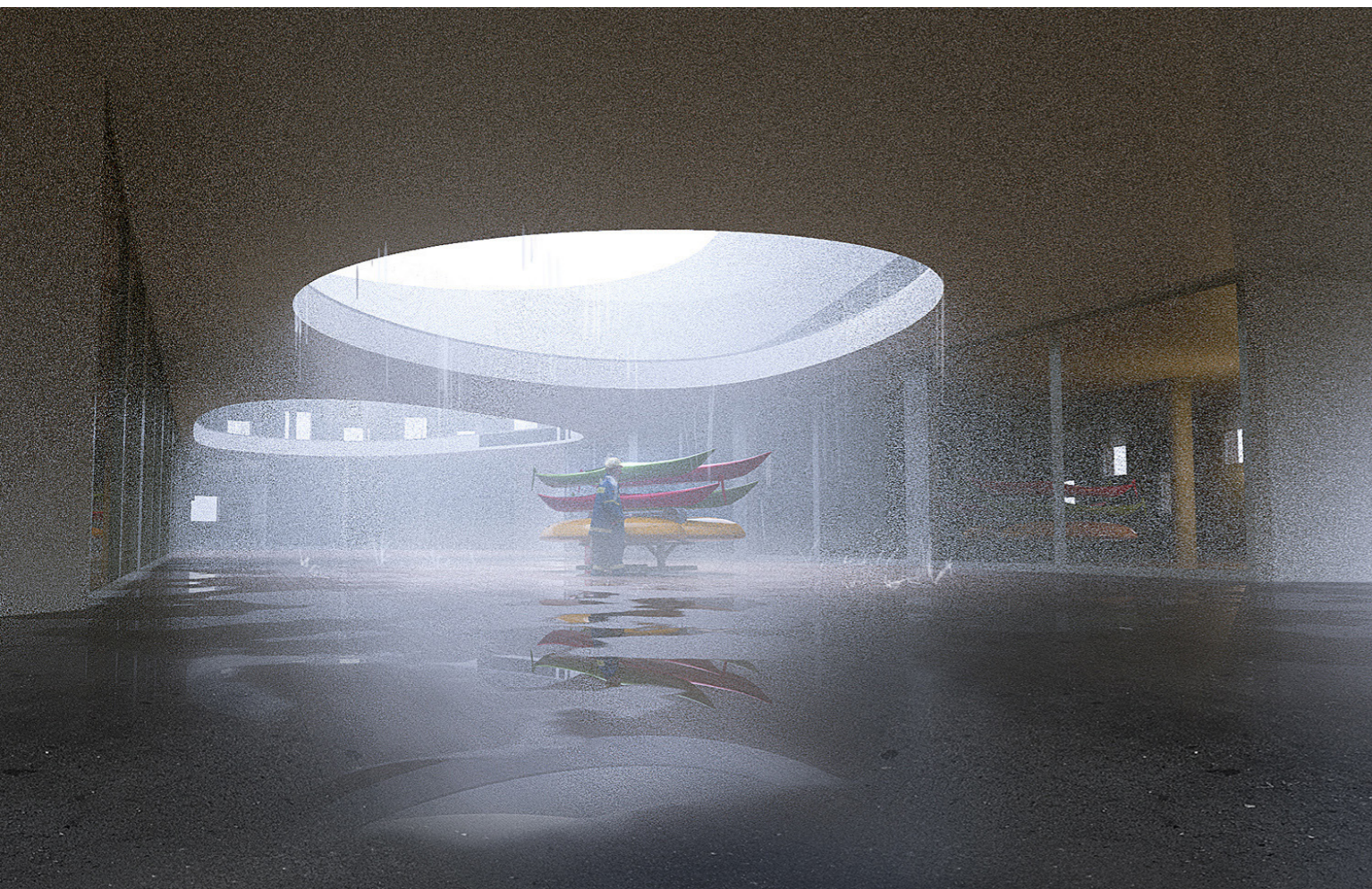
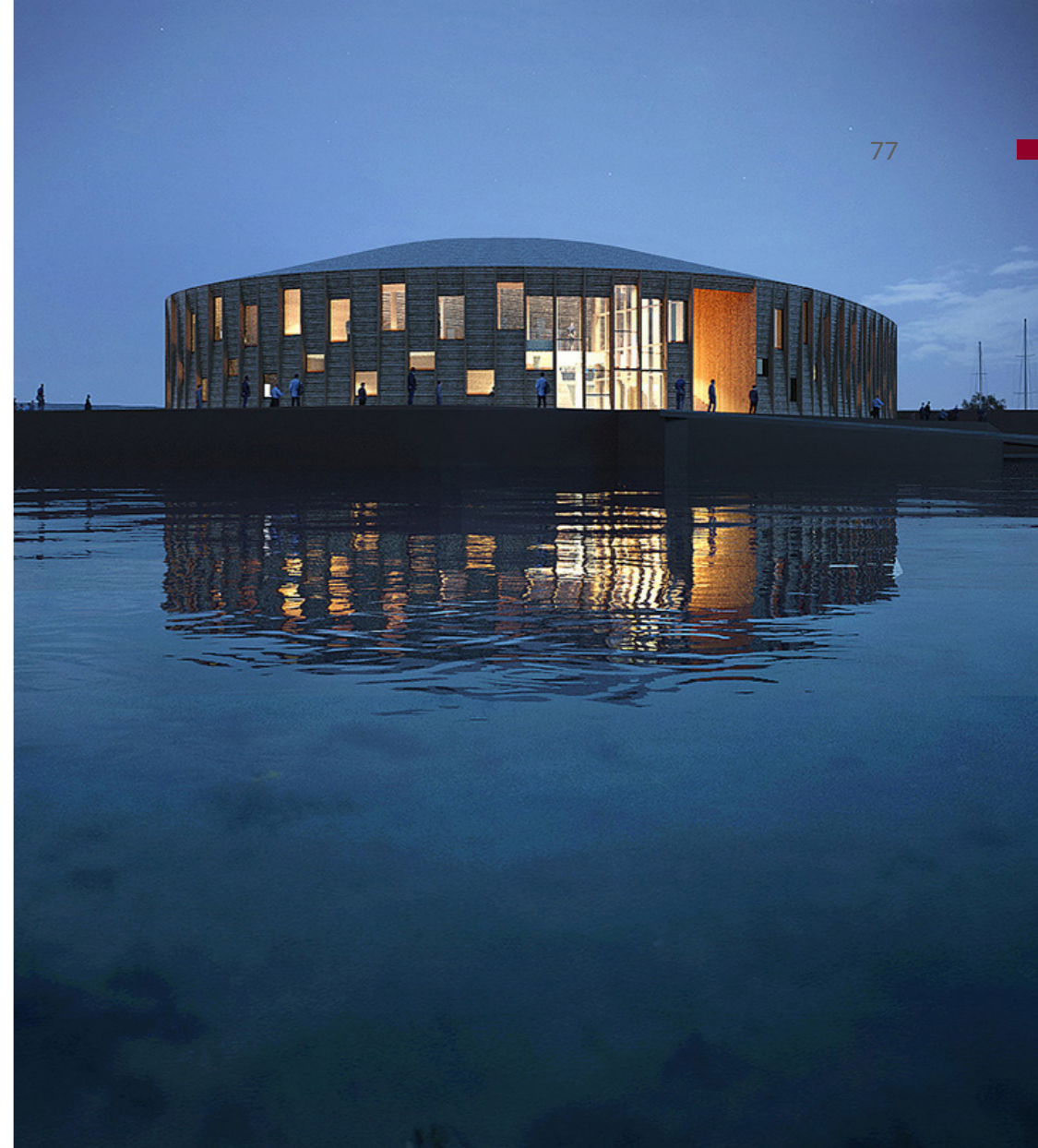

PRECEDENT STUDIES (SIMILAR PROJECTS)

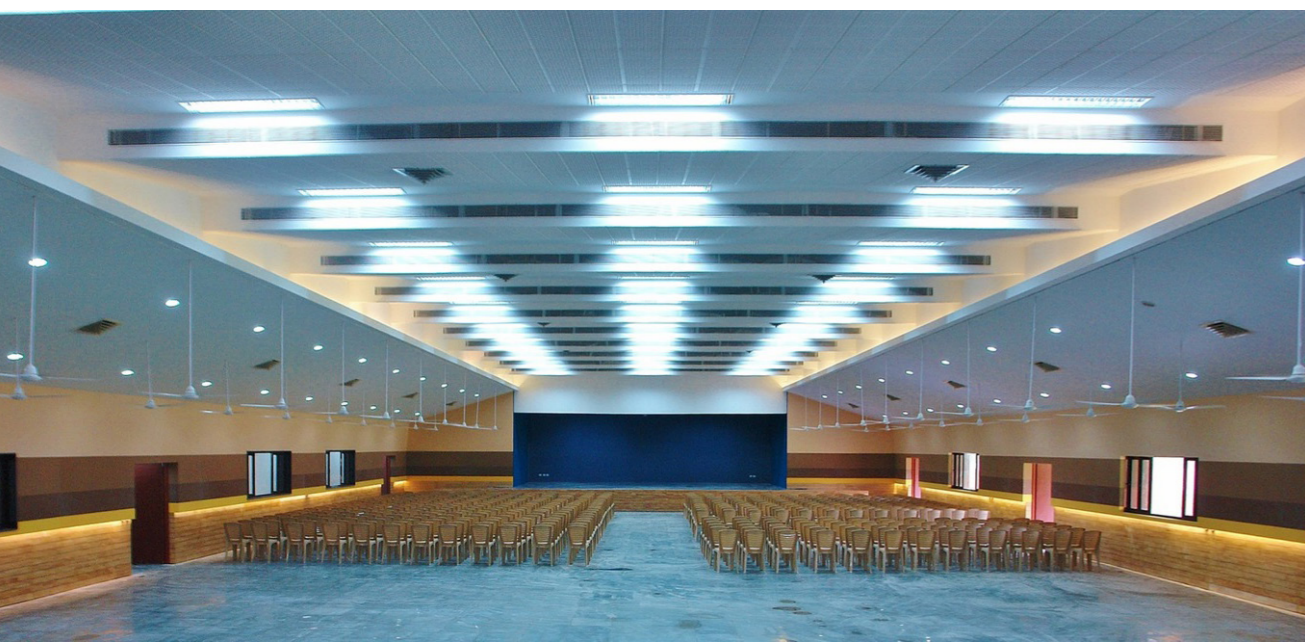

PRECEDENT STUDIES (CONCLUSION)

Projects with similar urban context, functionality, virtues and goals were studied and selected upon criteria that matches ICH's visions and objectives, and a great deal of information was learned from each of them, from a functional program and spacial requirements, to the fulfillment of the community and students' needs.

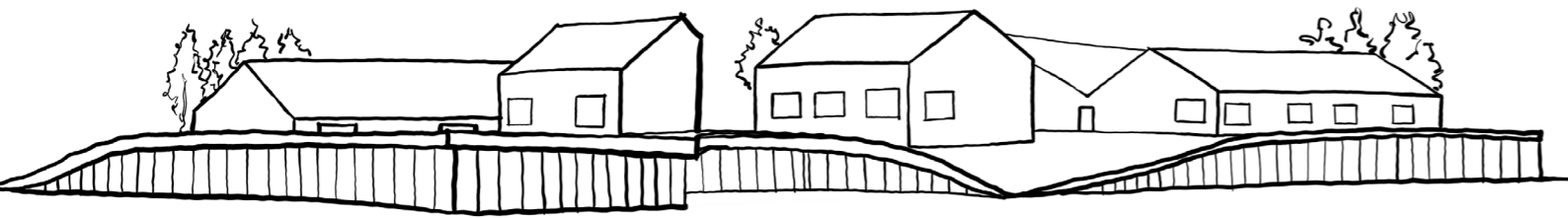

Kobenhavn Student Center by Nicolas Maugery

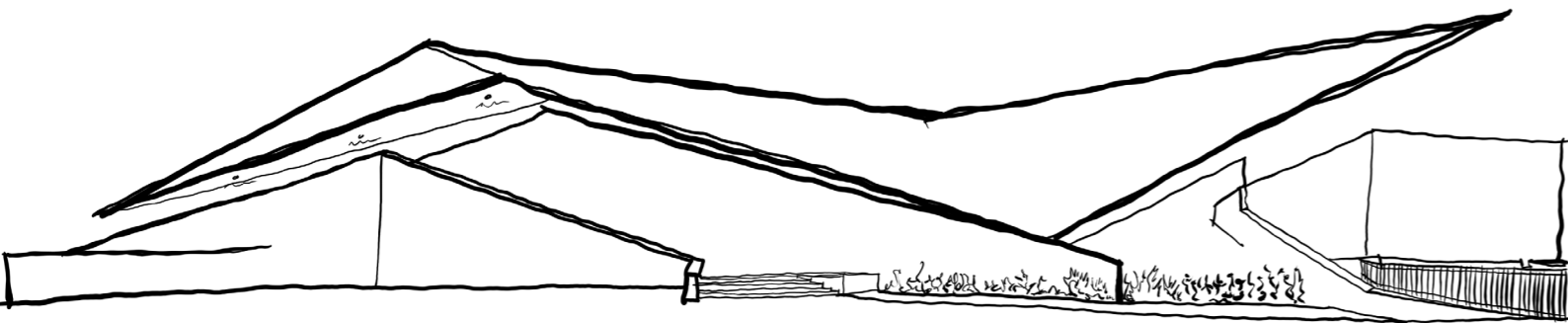

Valpoi Busstand and Community Hall by Rahul Deshpande and Associates

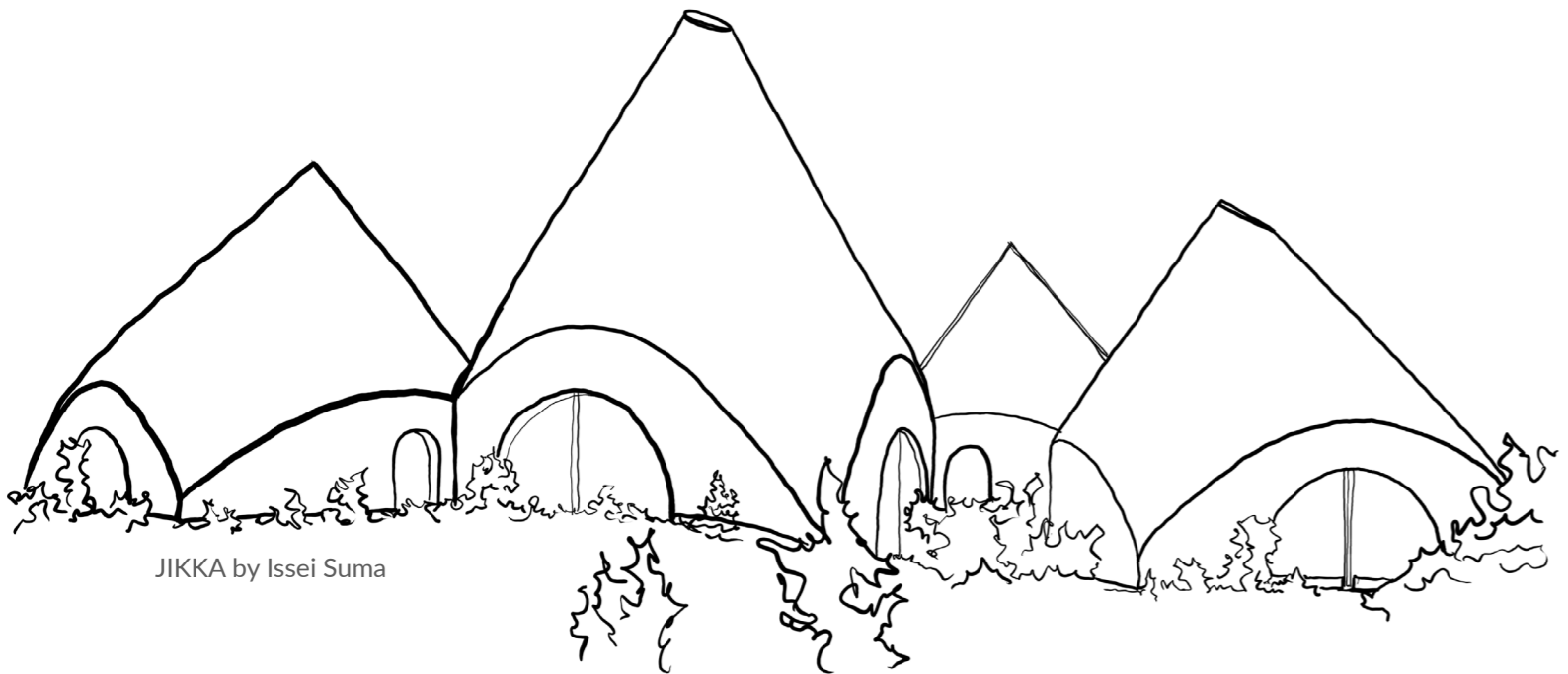

JIKKA by Issei Suma

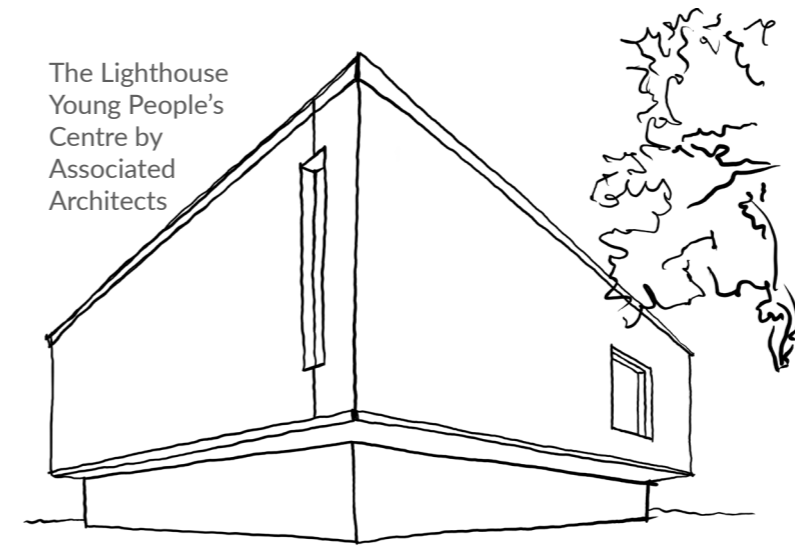

The Lighthouse Young People's Centre by Associated Architects

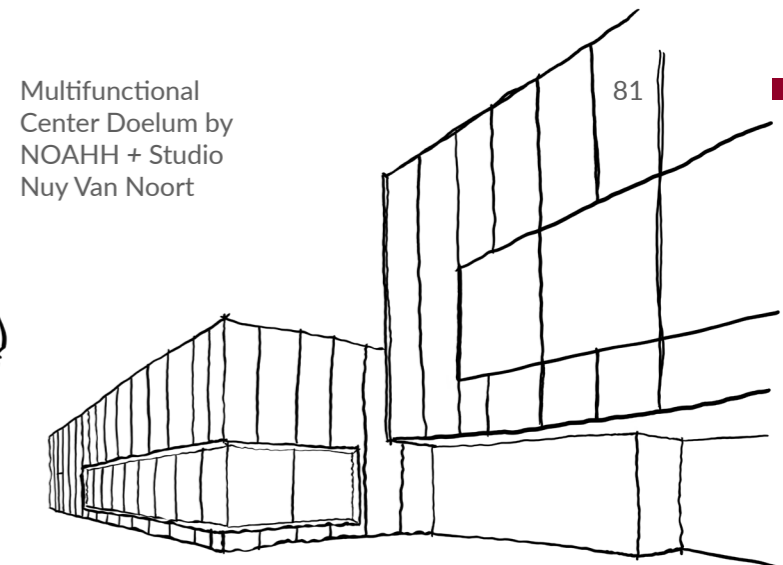

Multifunctional Center Doelum by NOAHH + Studio Nuy Van Noort

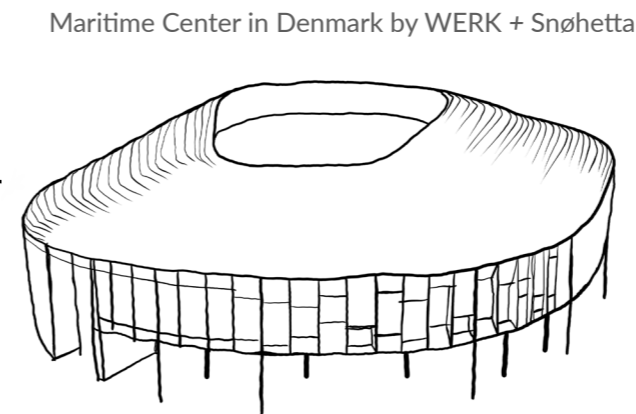

Maritime Center in Denmark by WERK + Snøhetta



Moncayo Club House by Iconico Studio

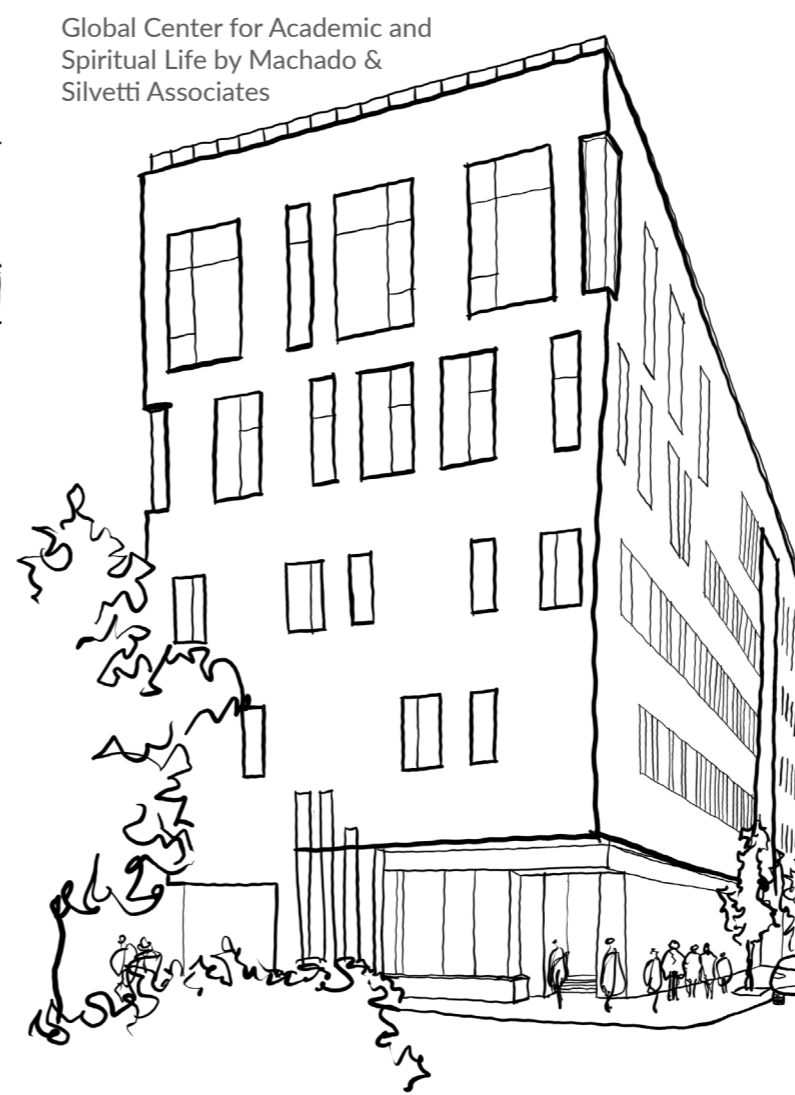

Global Center for Academic and Spiritual Life by Machado & Silvetti Associates



Waiinga Martinborough Community Centre by Warren and Mahoney

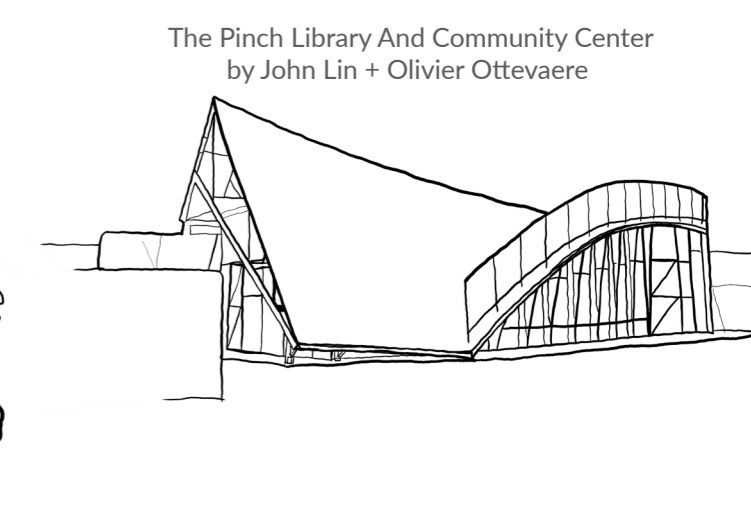

The Pinch Library And Community Center by John Lin + Olivier Ottevaere

ICH DESIGN CONCEPT

CONTEXT

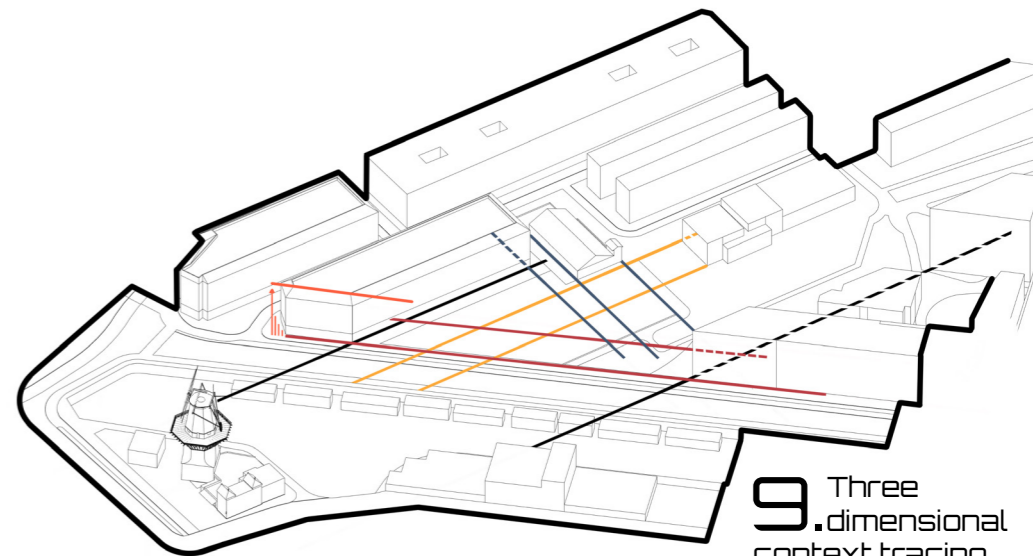
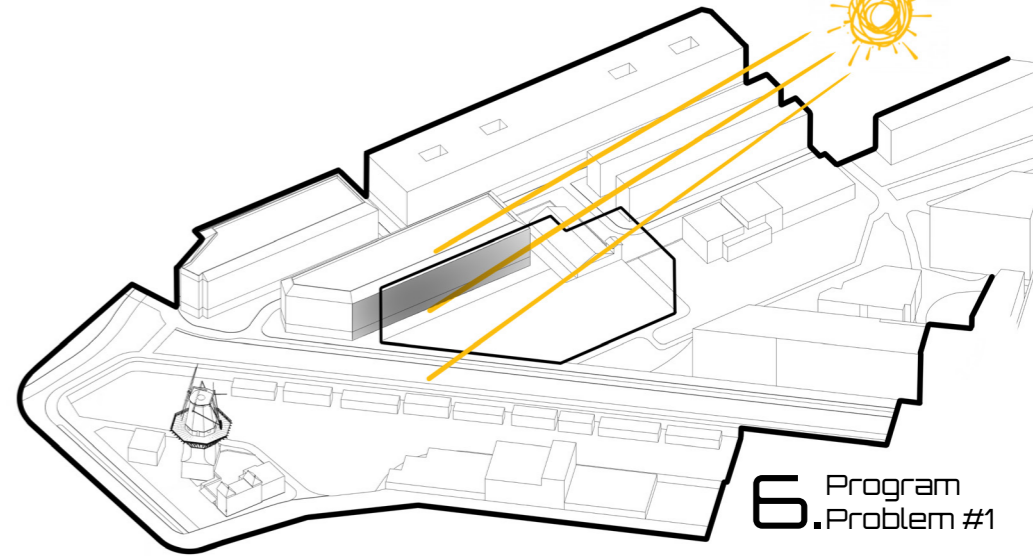
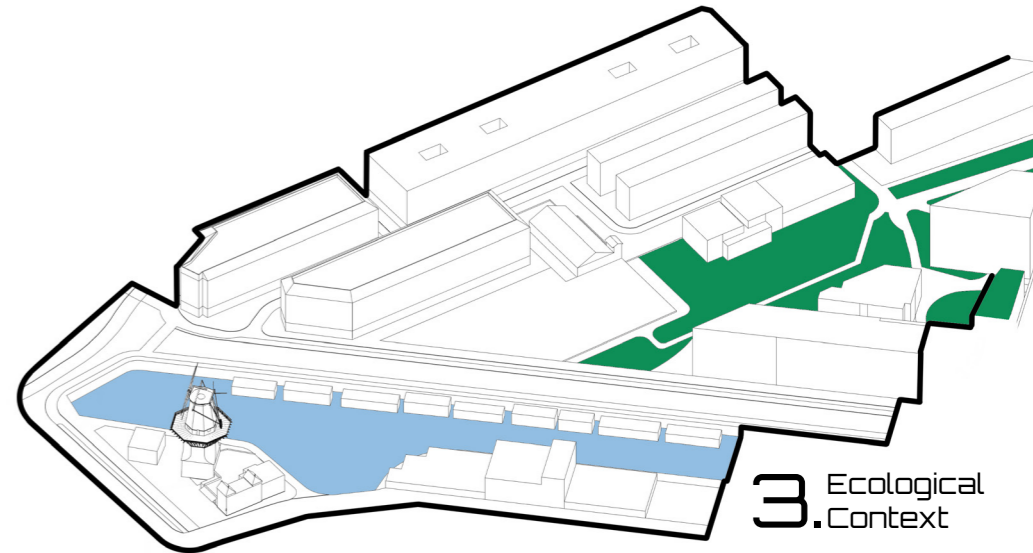
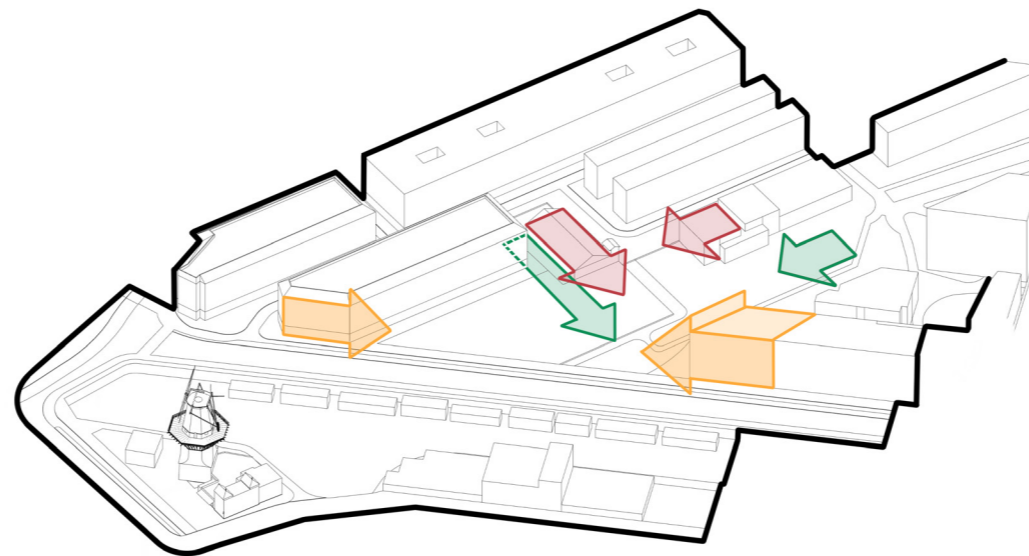
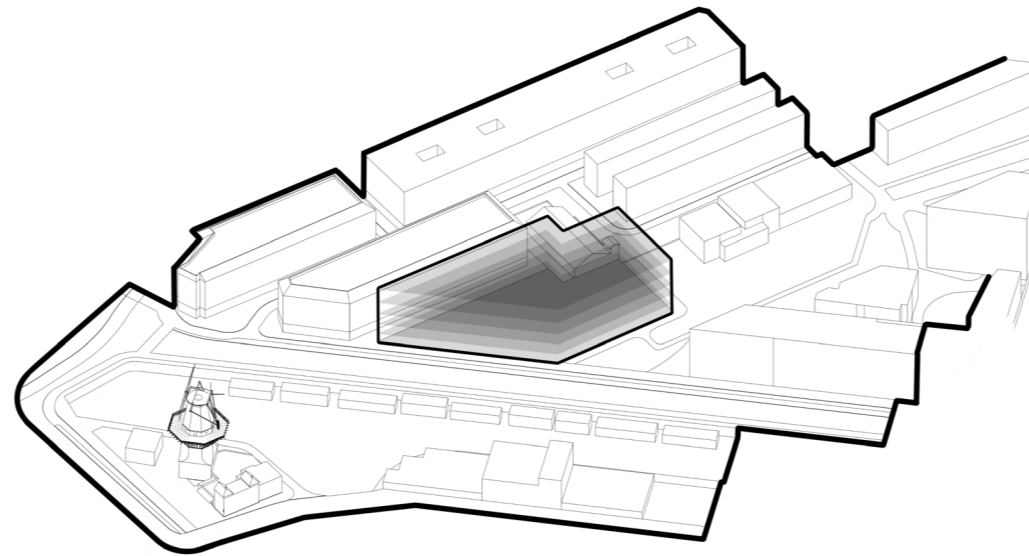
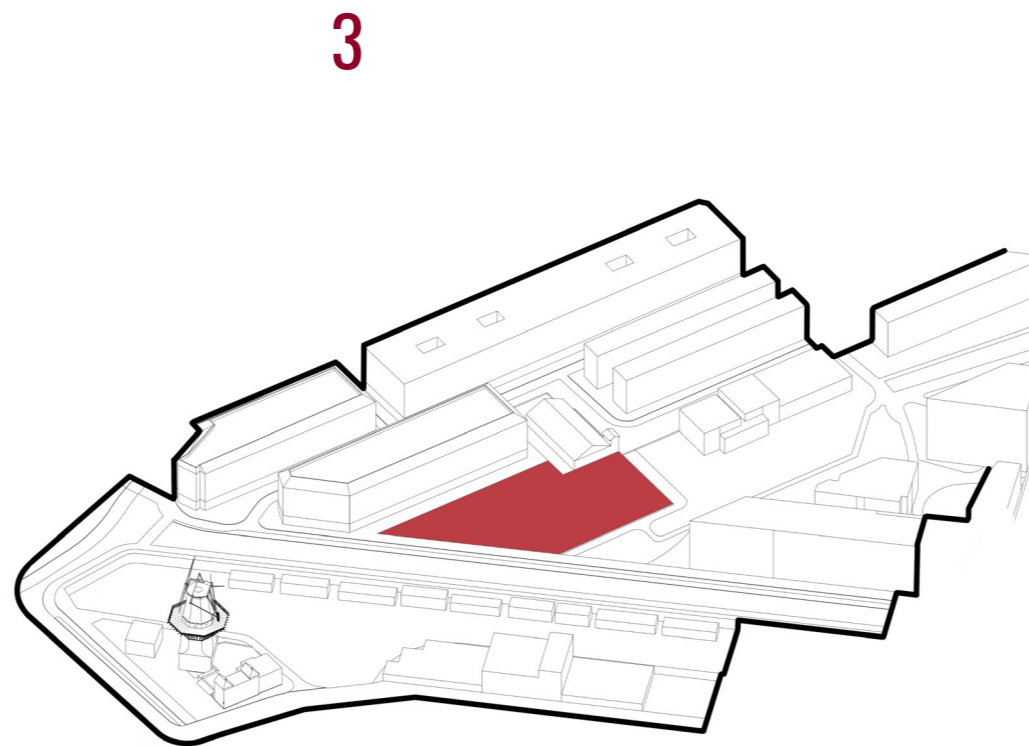
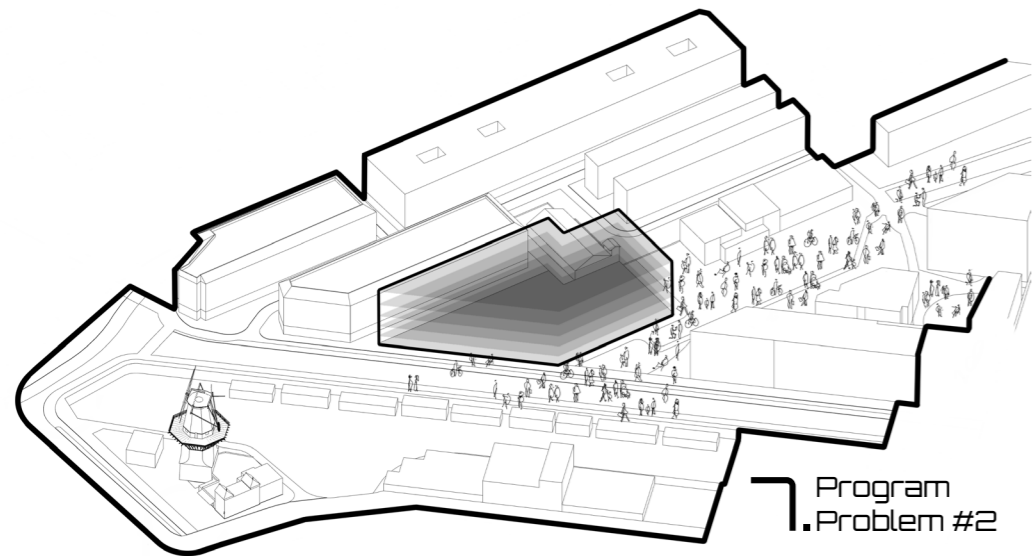
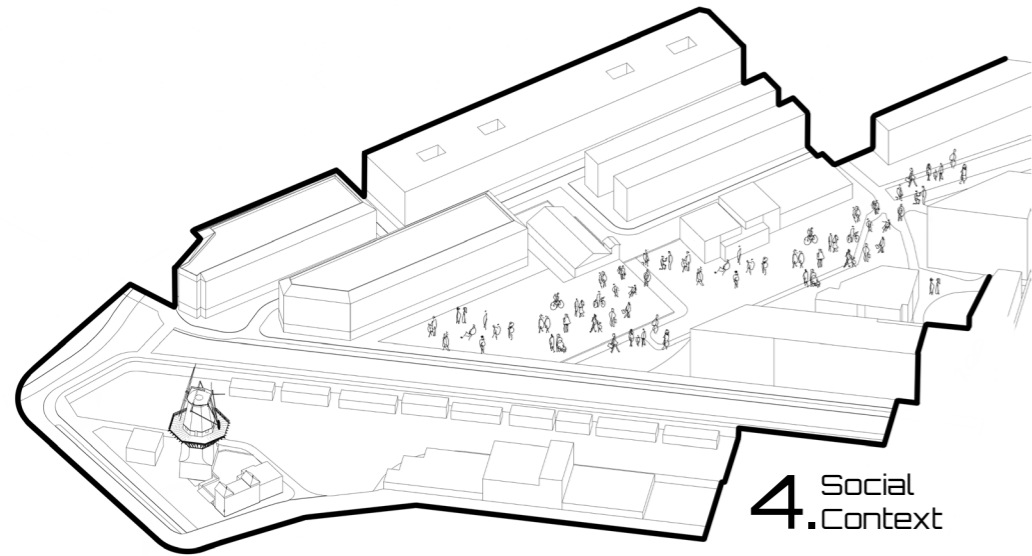
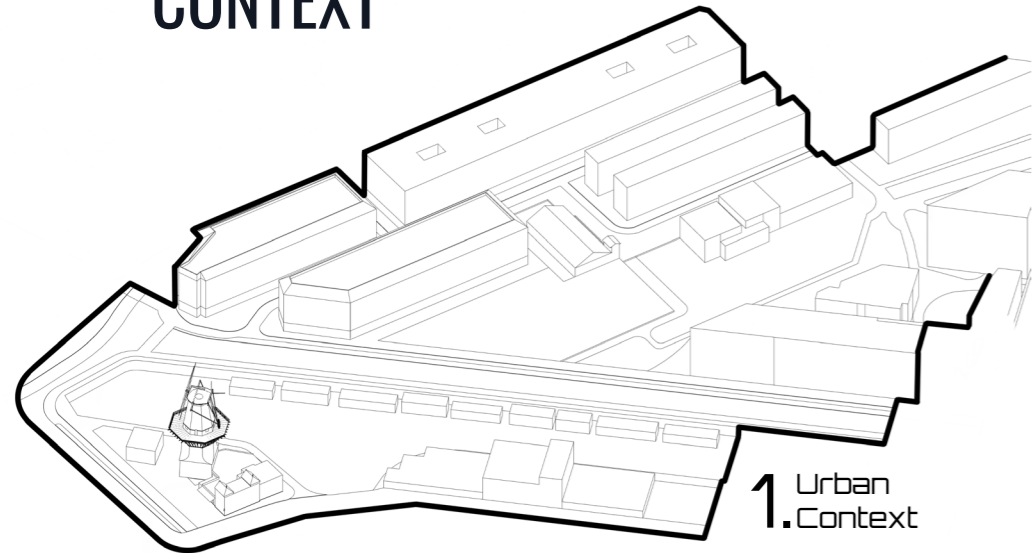

ICH DESIGN CONCEPT

SOLUTION- & FORM-FINDING

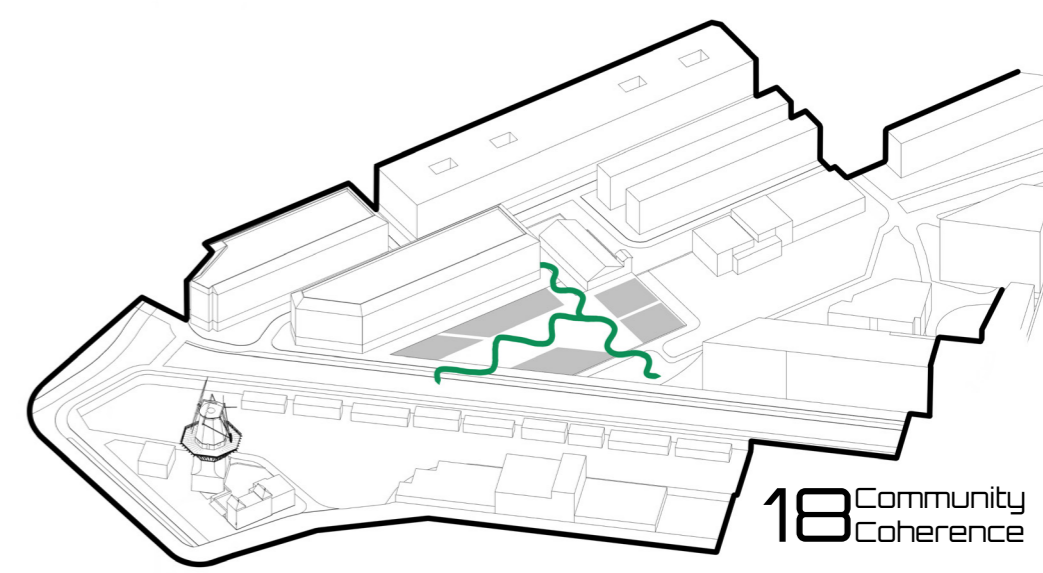
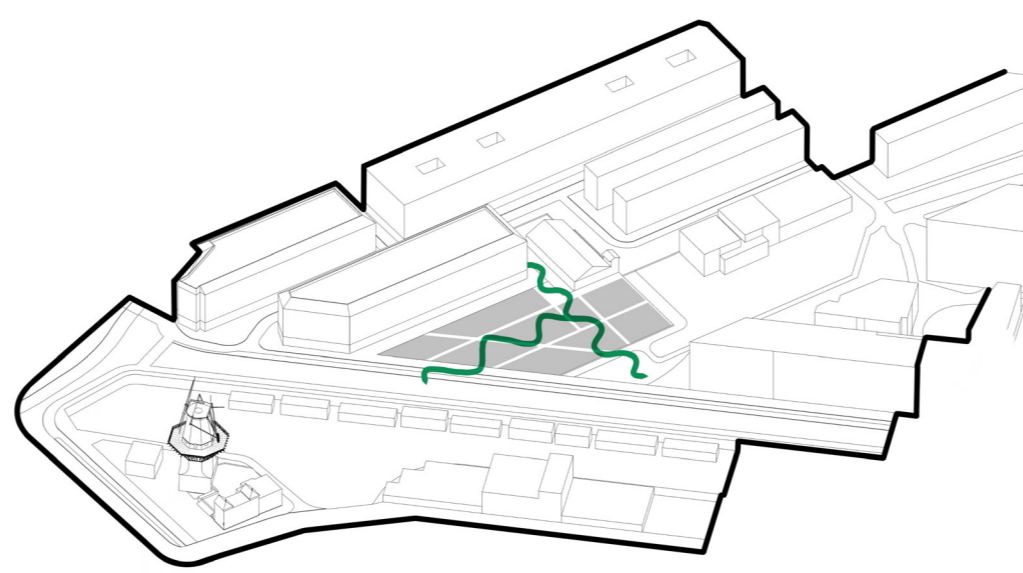
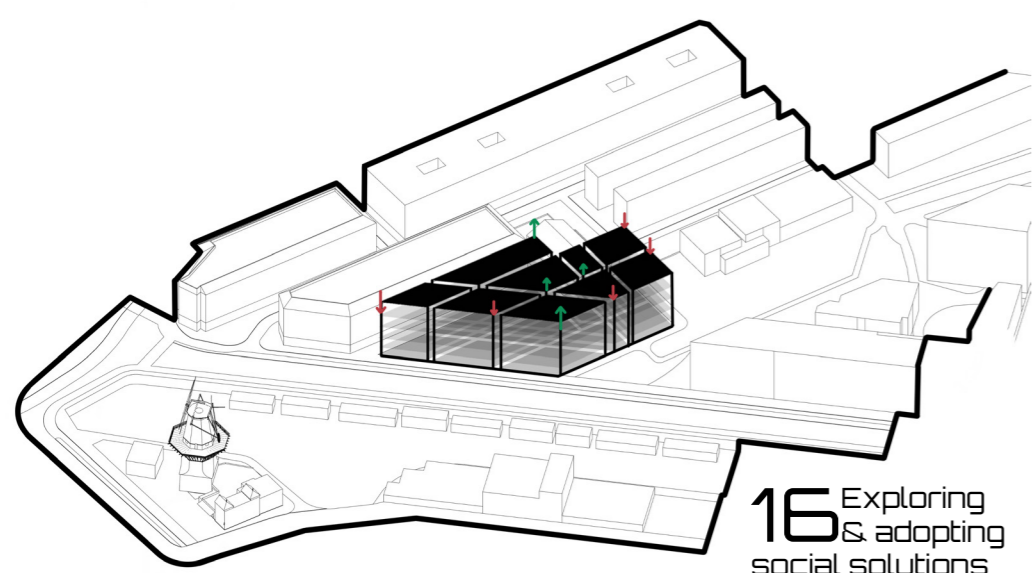
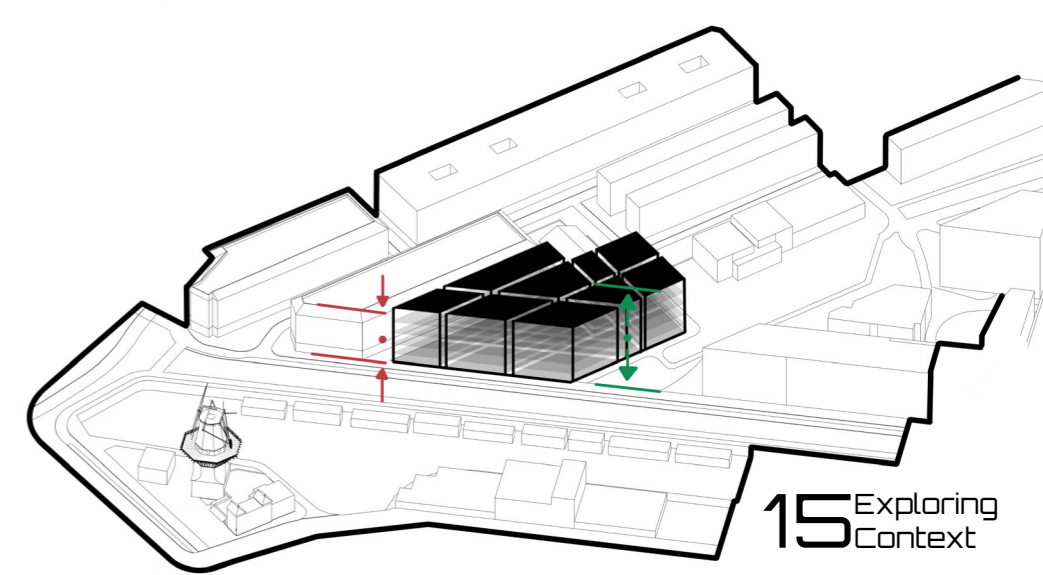
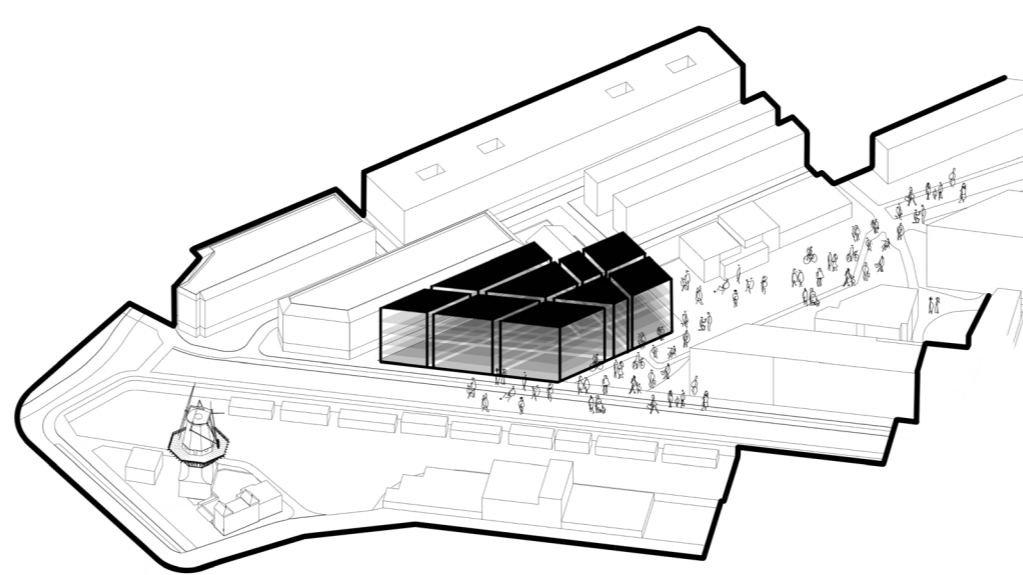
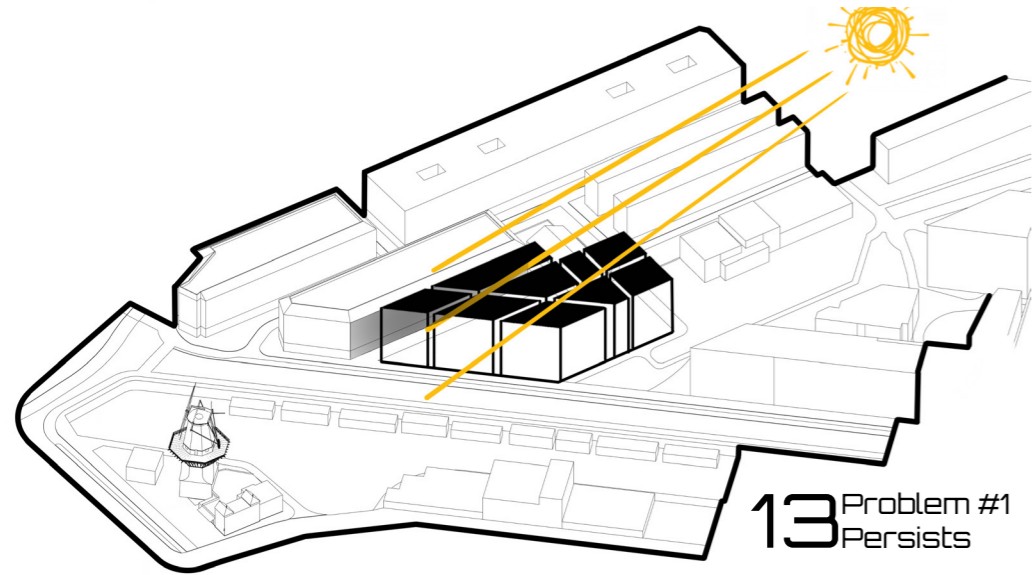
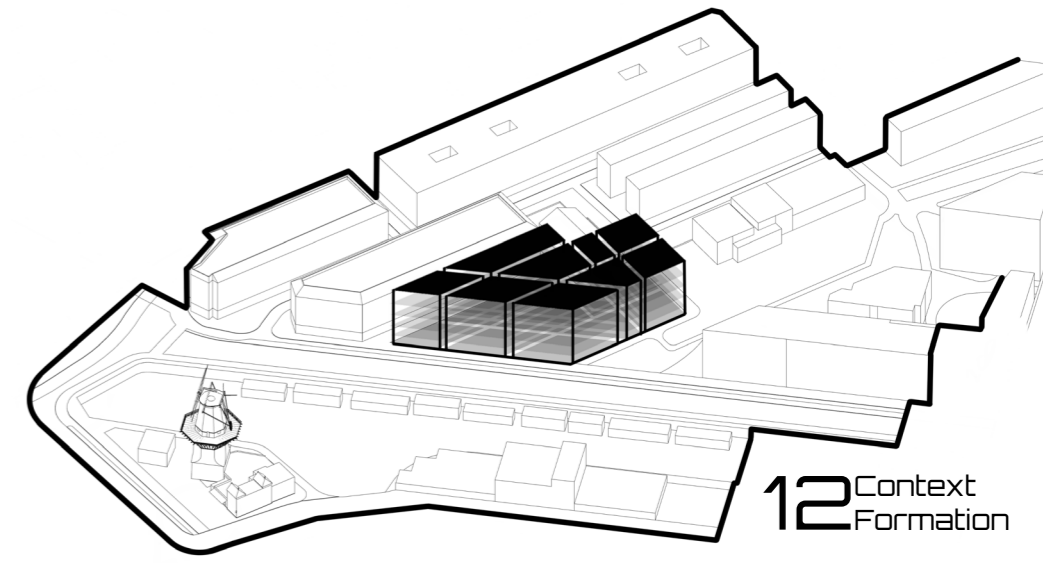
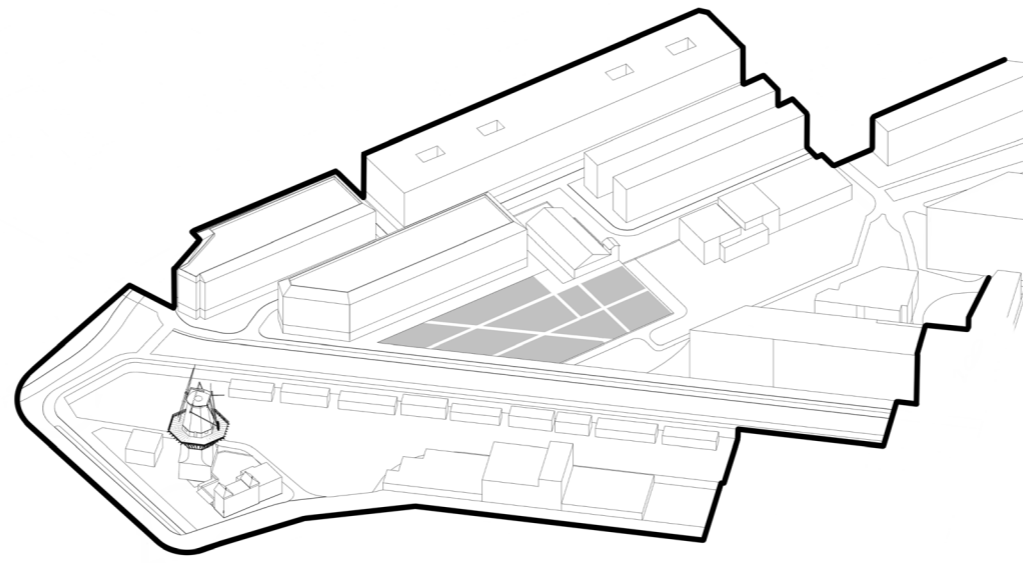
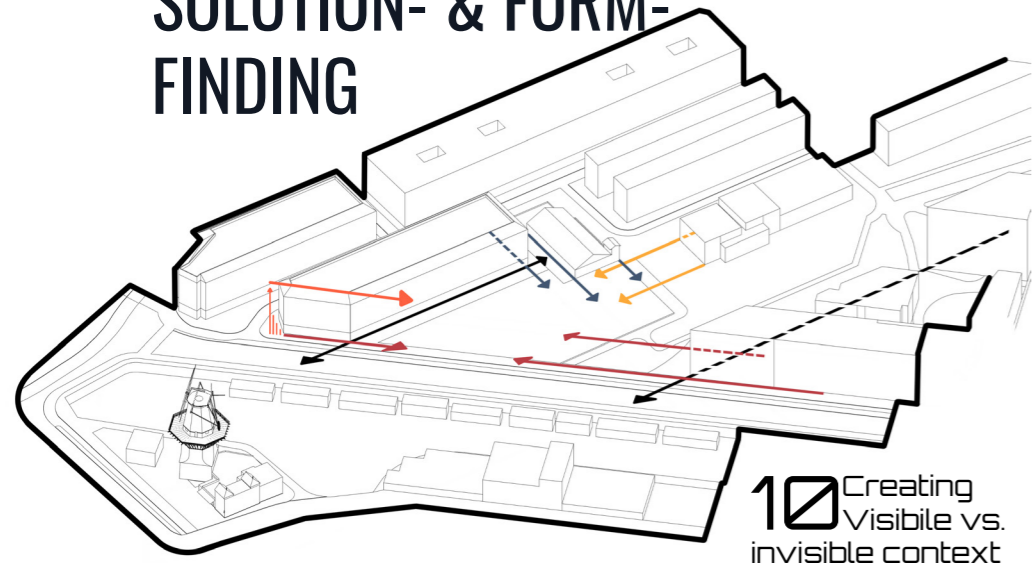

ICH DESIGN CONCEPT

FINAL SOLUTIONS

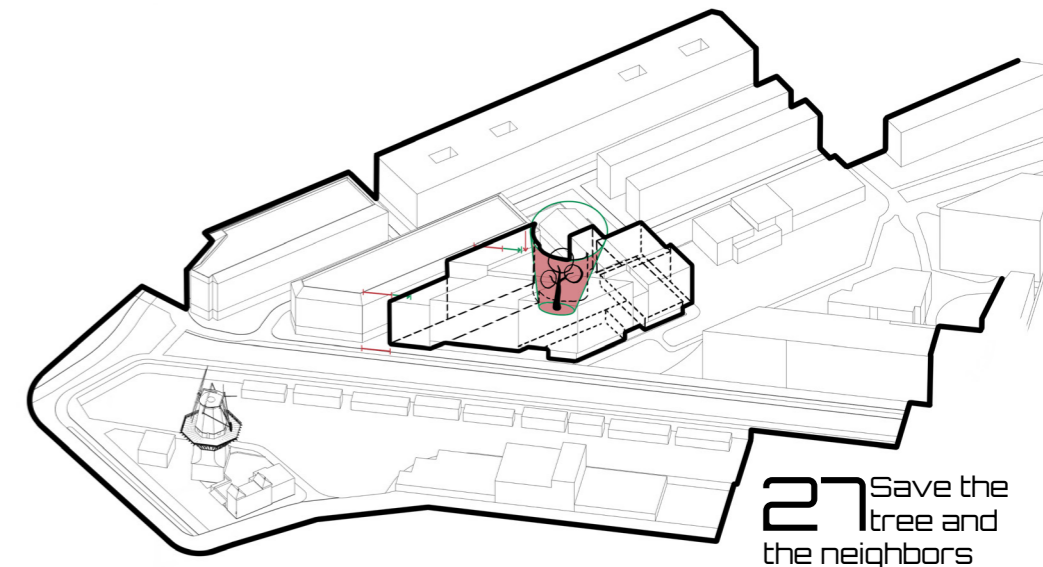
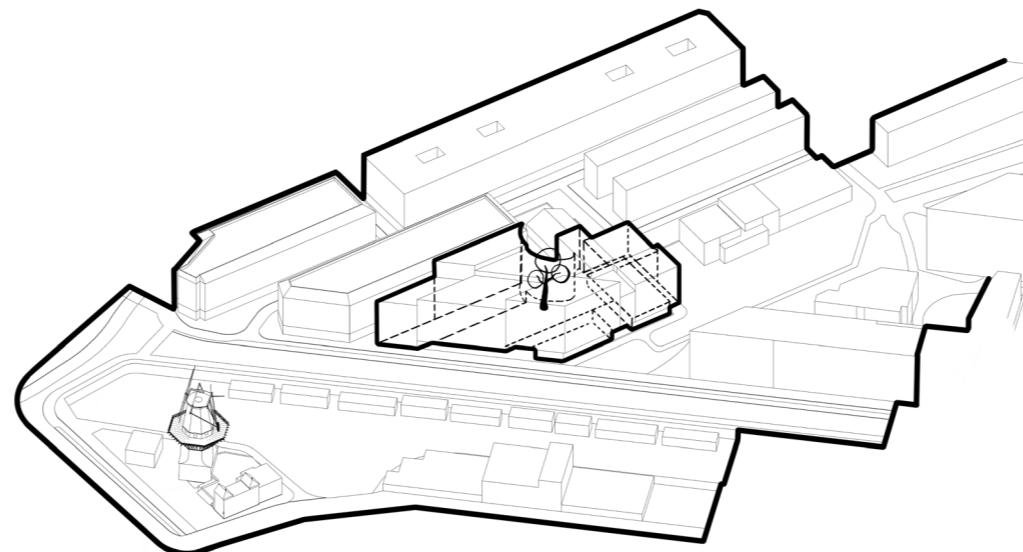
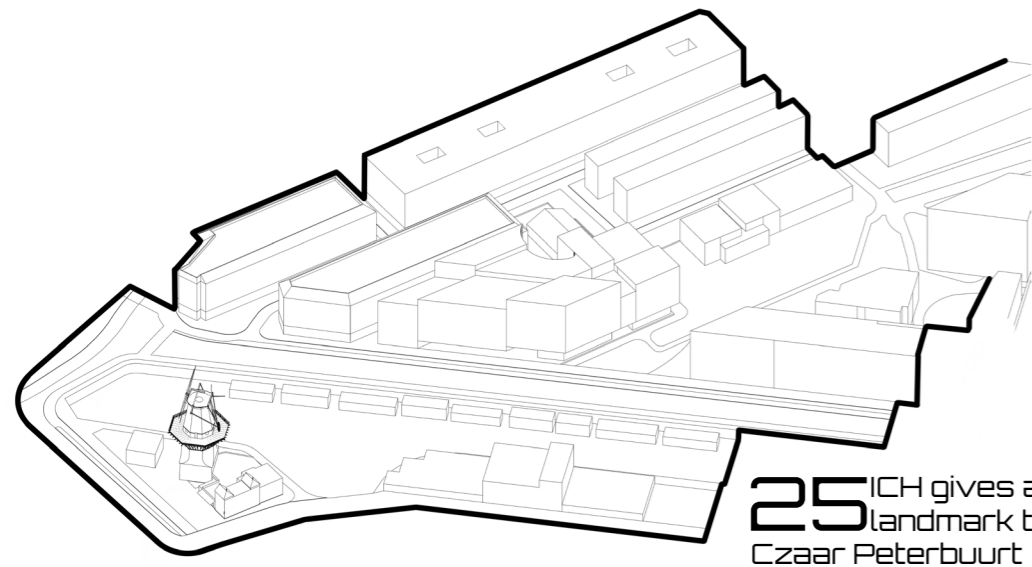
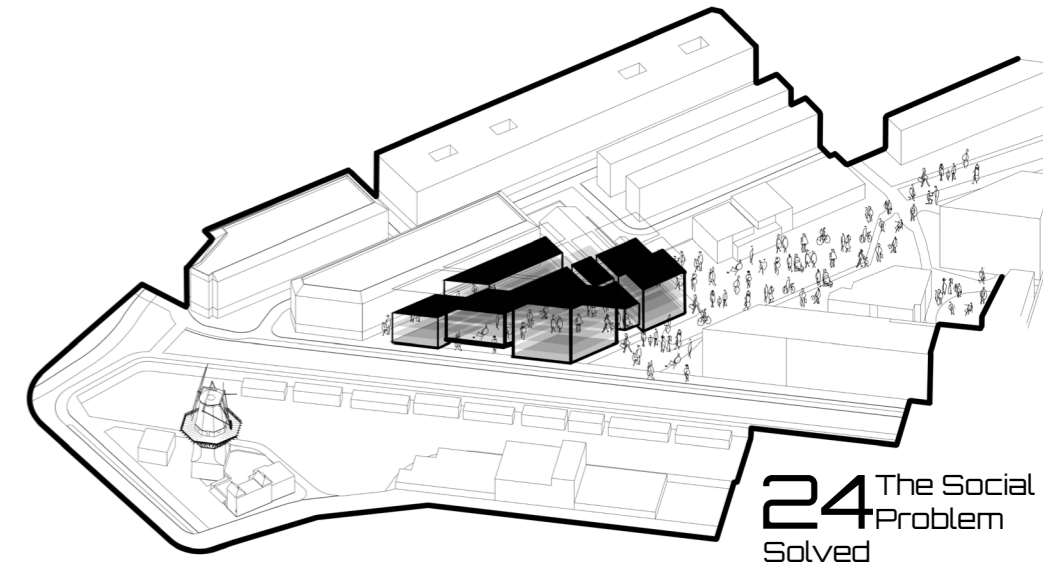
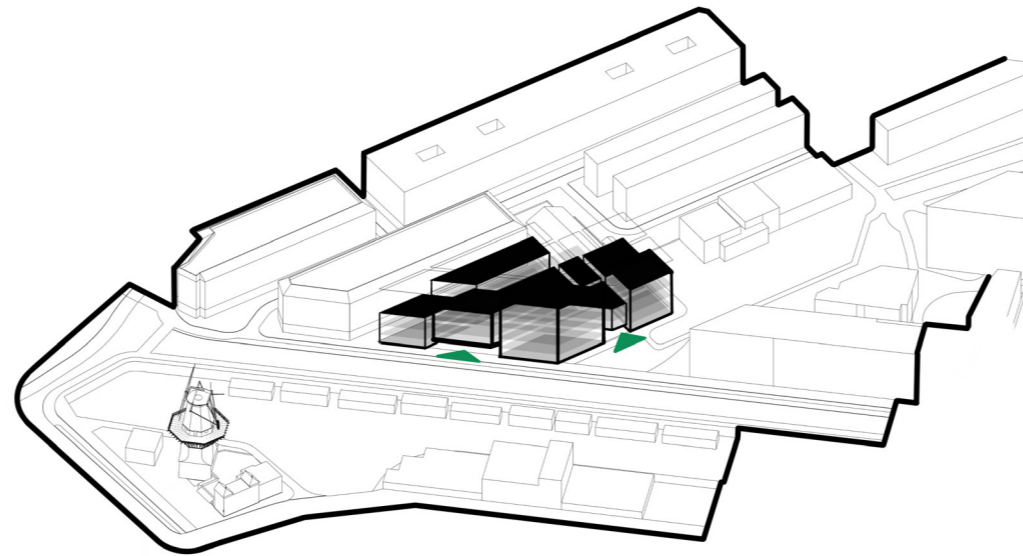
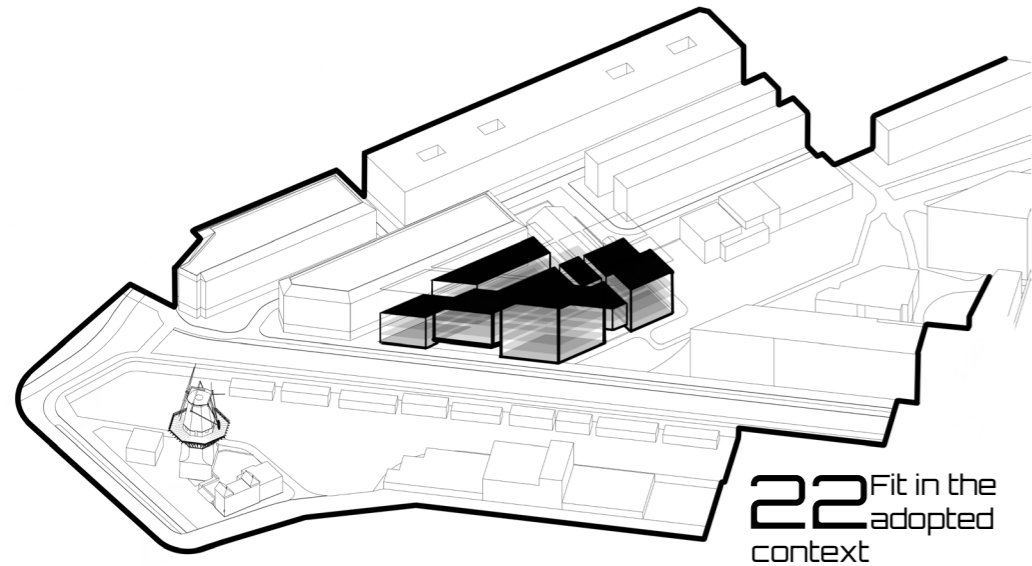
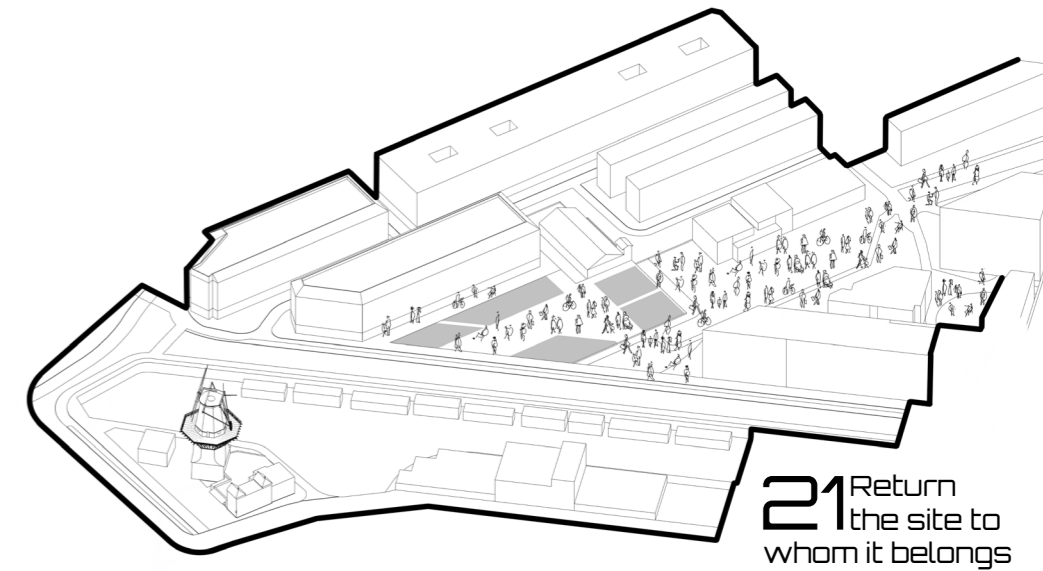
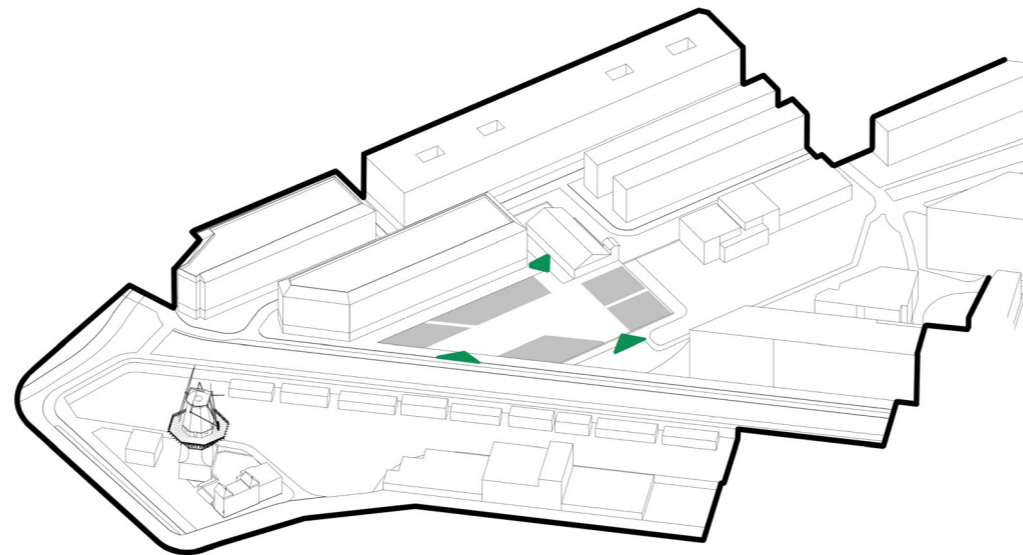
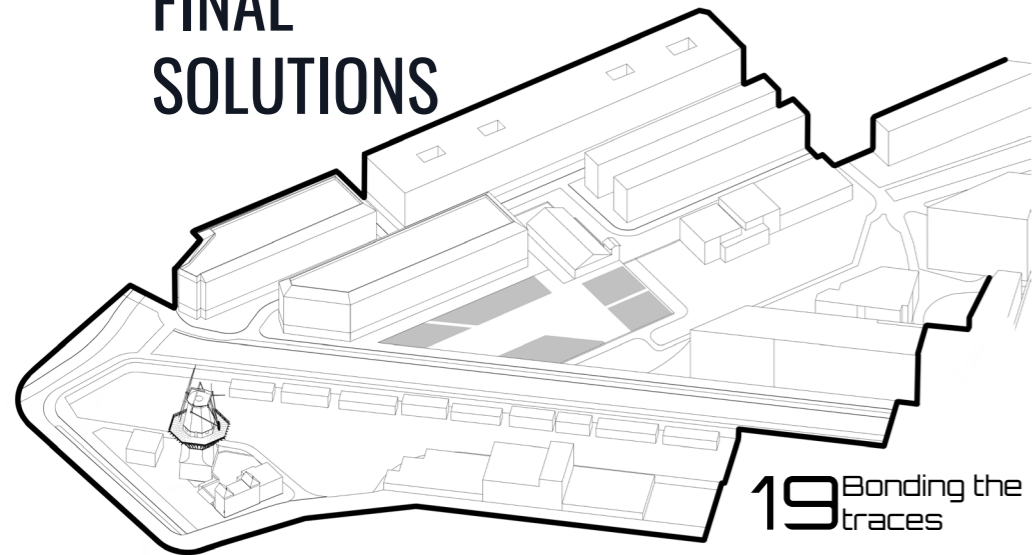

ICH DESIGN CONCEPT

FINAL SOLUTIONS

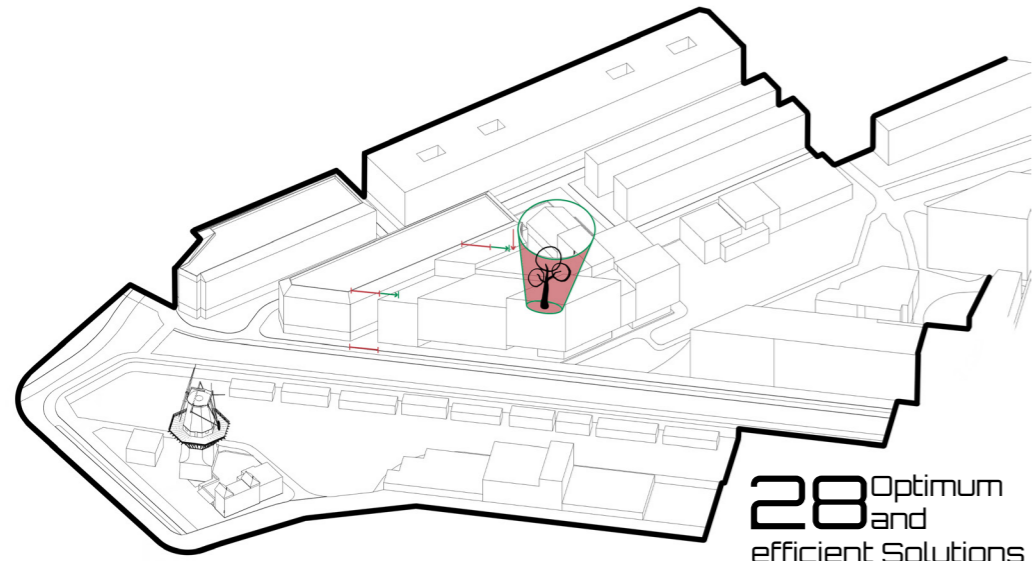

28 Optimum and efficient Solutions

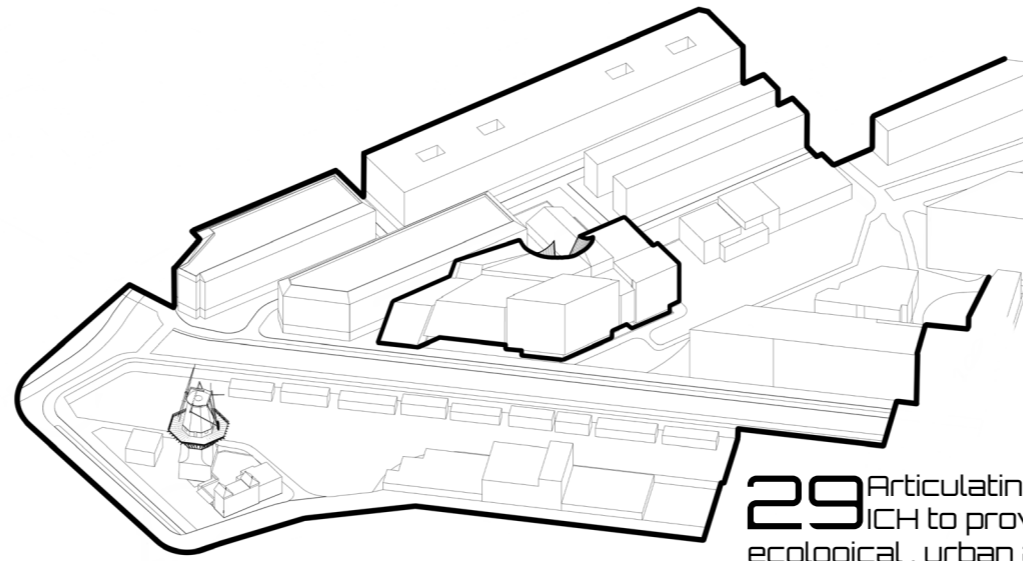

29 Articulating ICH to provide ecological, urban and social solutions

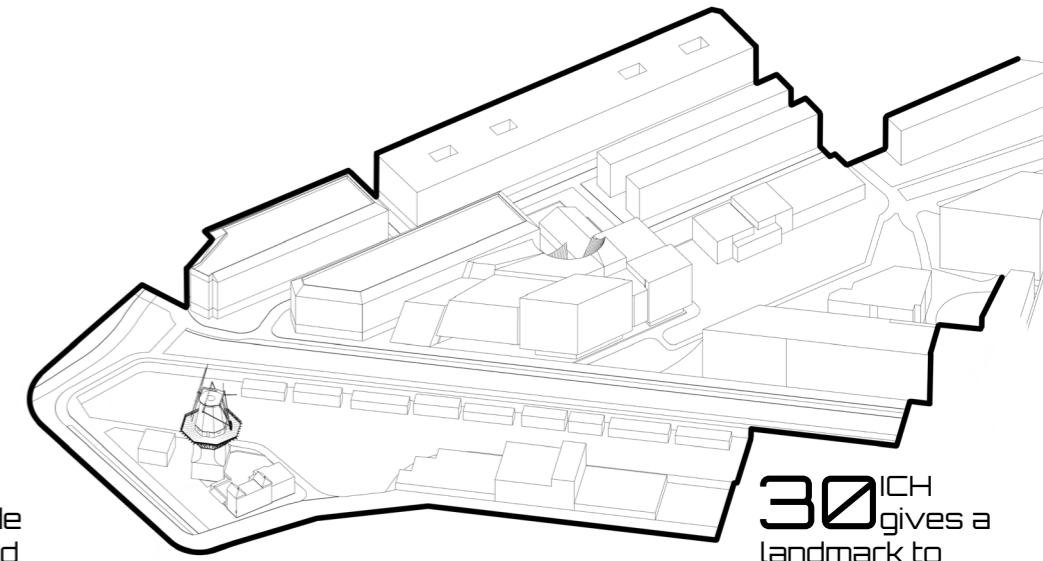

30 ICH gives a landmark to Czaar Peterbuurt

31 Before Commencement



31 Input



31 Efficient Design

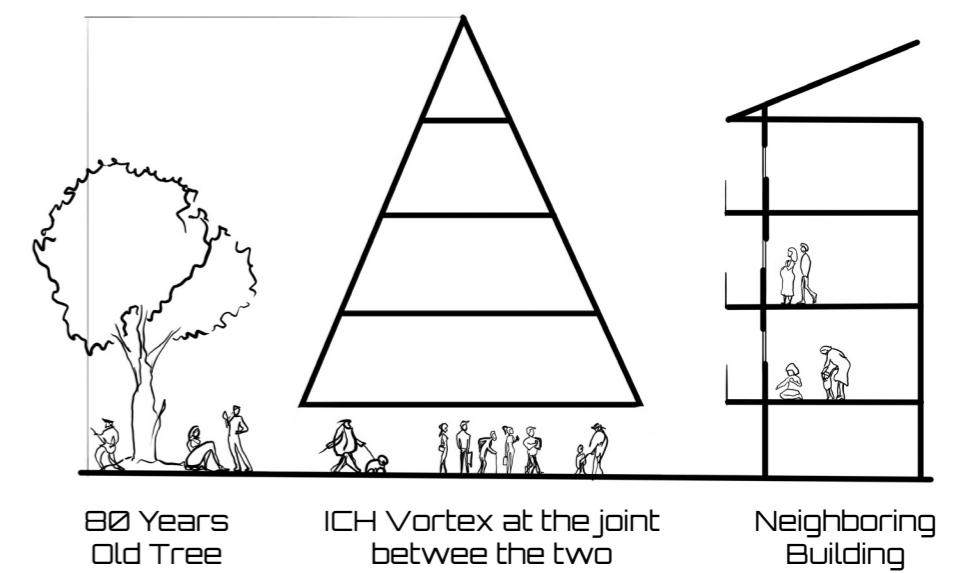
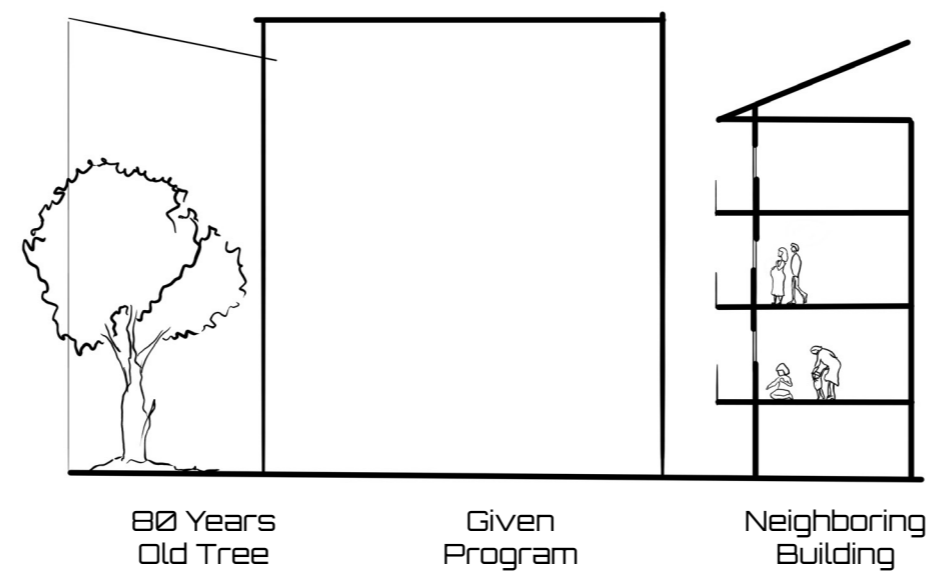
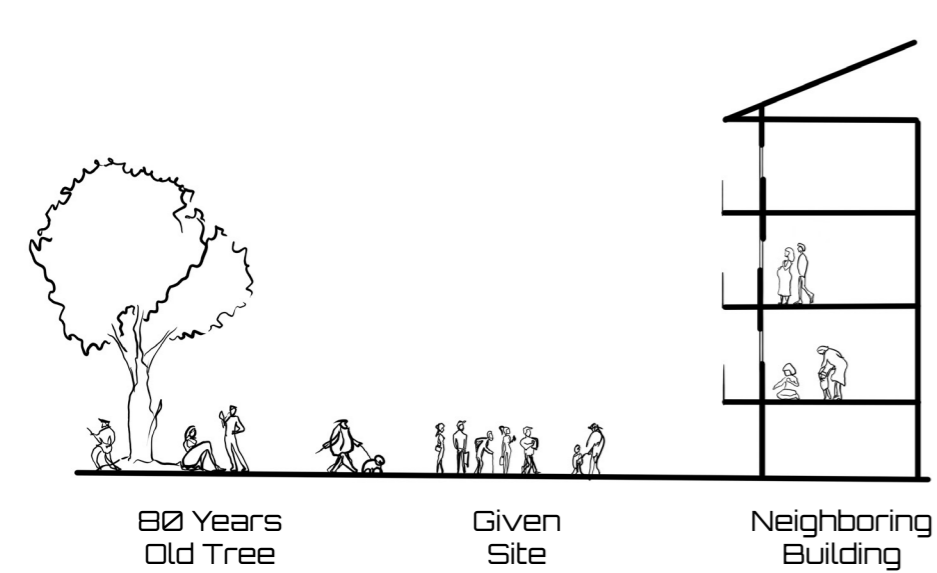

ICH MODEL



3D IMAGERY TO ILLUSTRATE THE DESIGN IDEAS

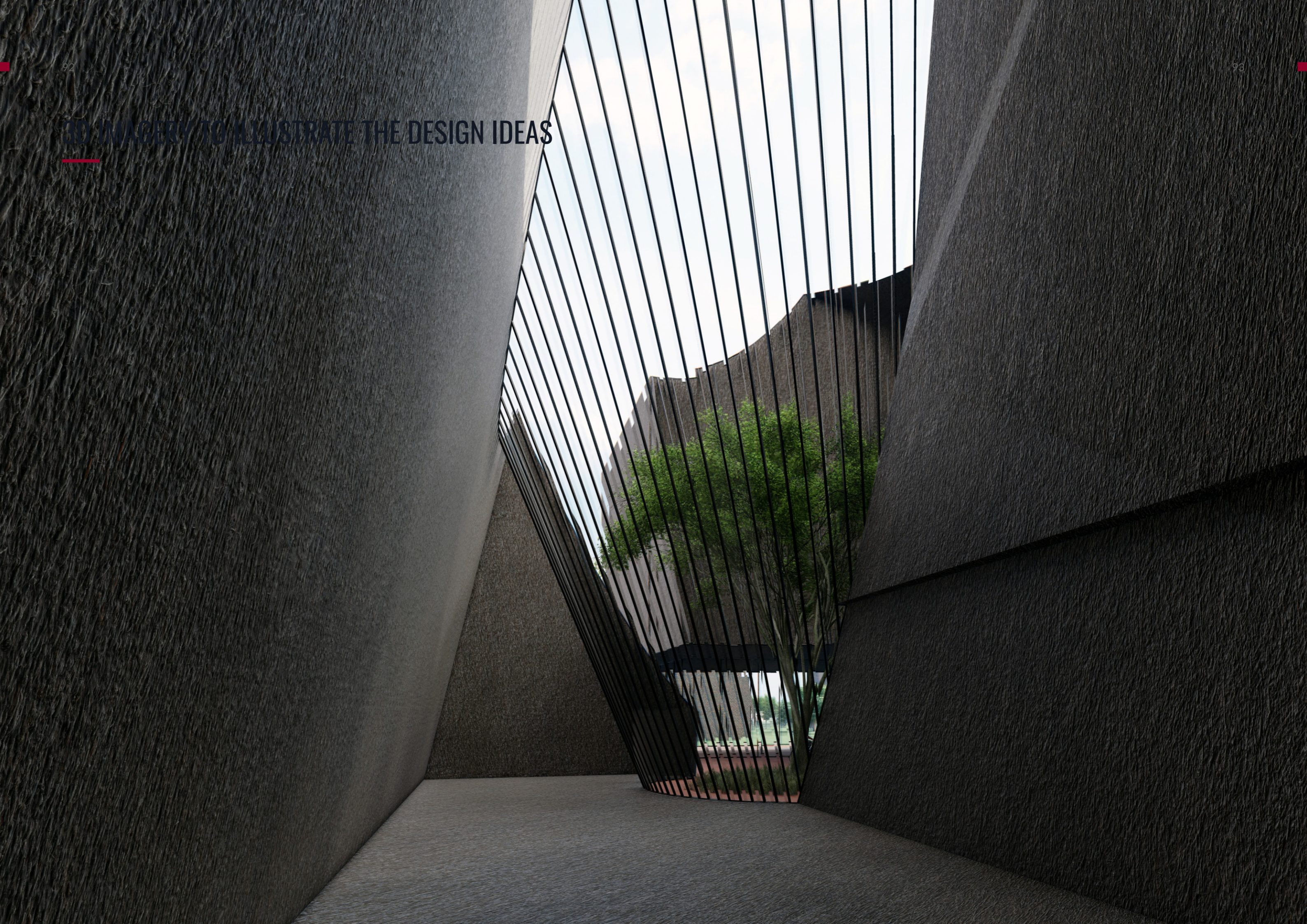



3D IMAGERY TO ILLUSTRATE THE DESIGN IDEAS FROM PAST SUBMISSIONS

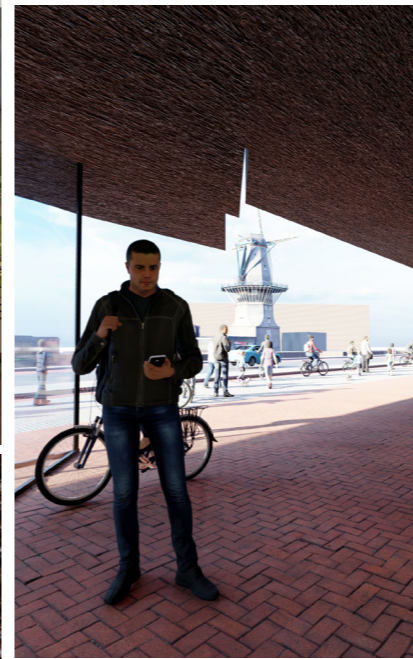
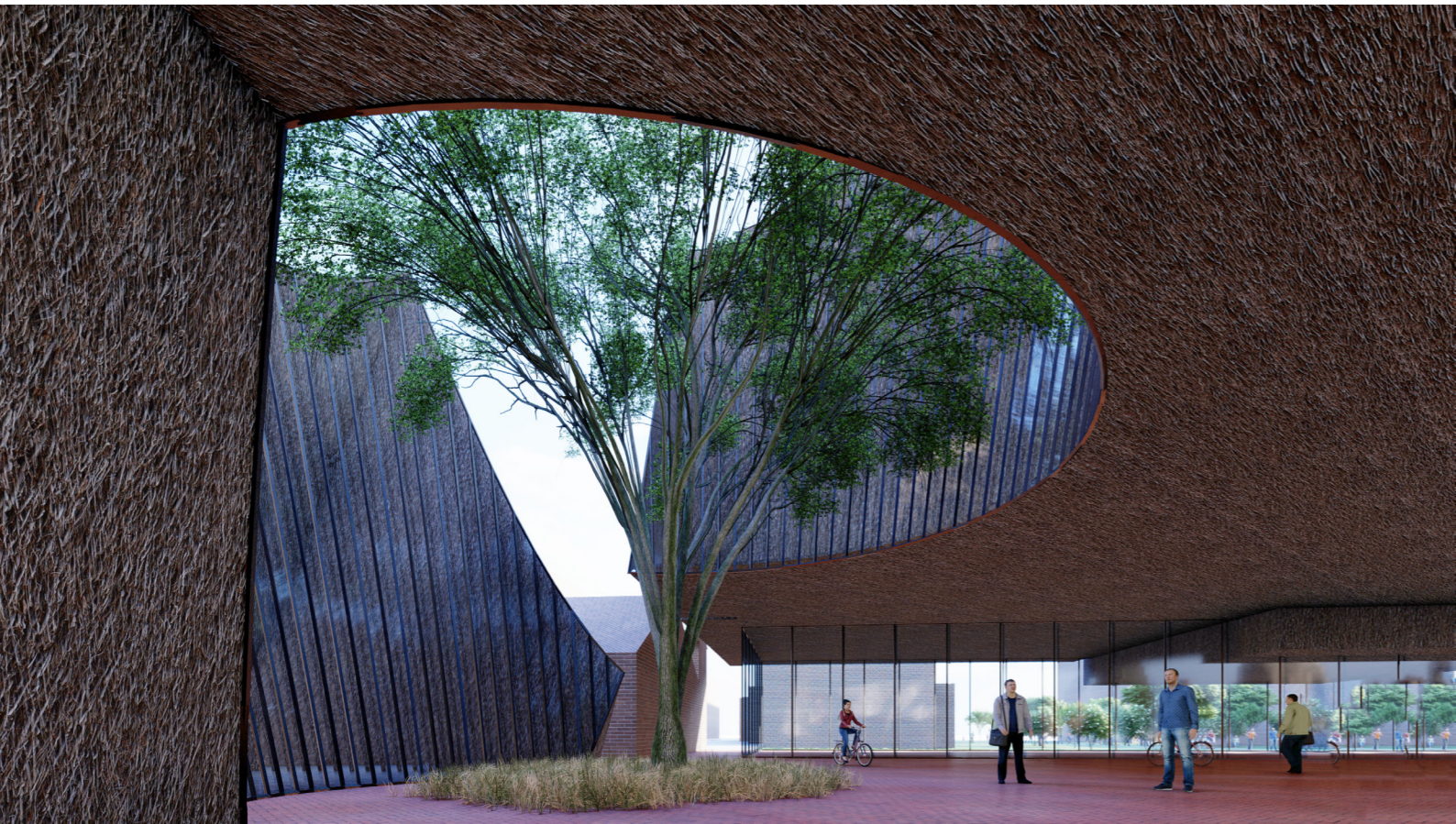
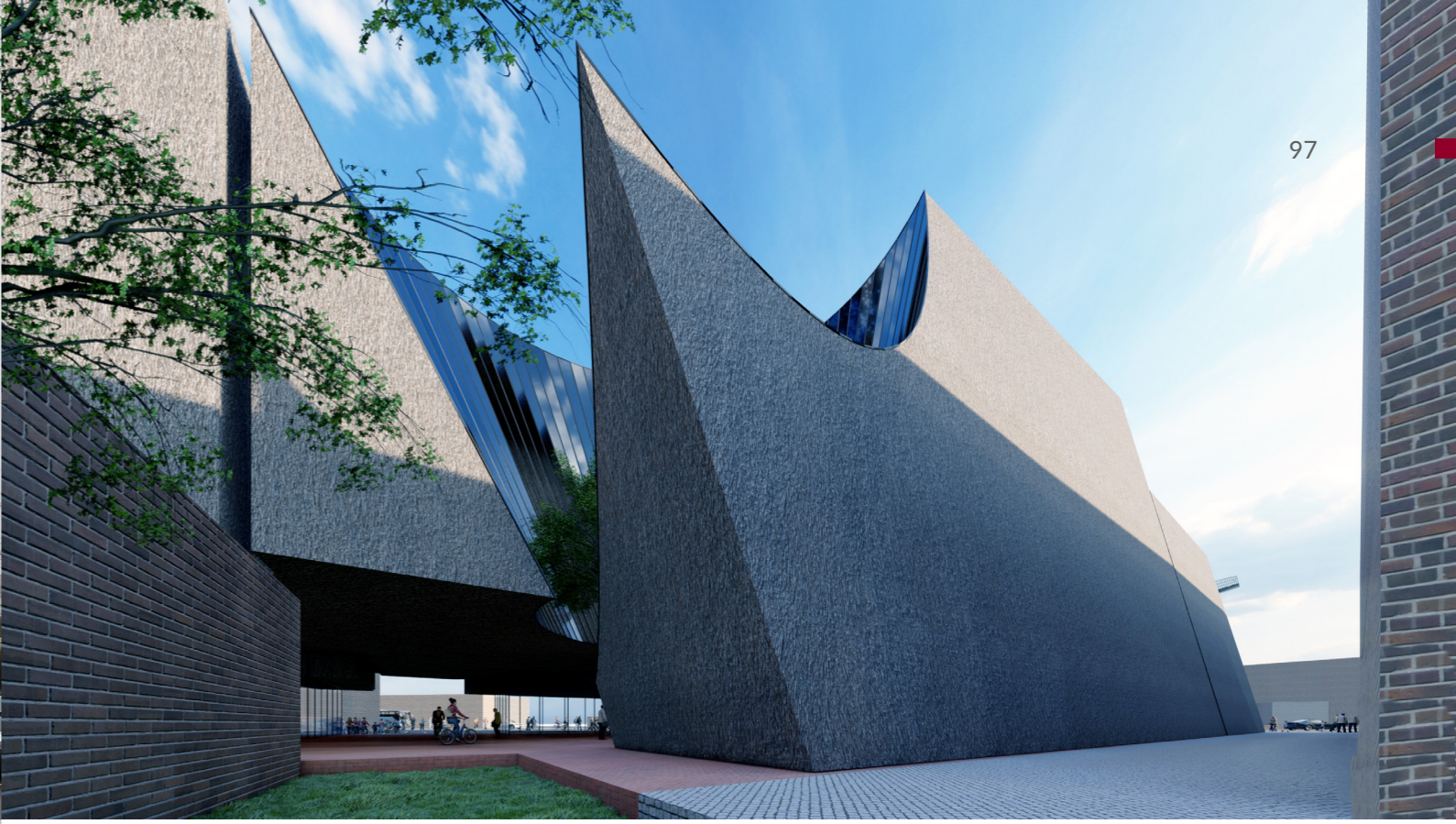

AERIAL SKETCH THE SITE LAYOUT



EARLY SKETCHES

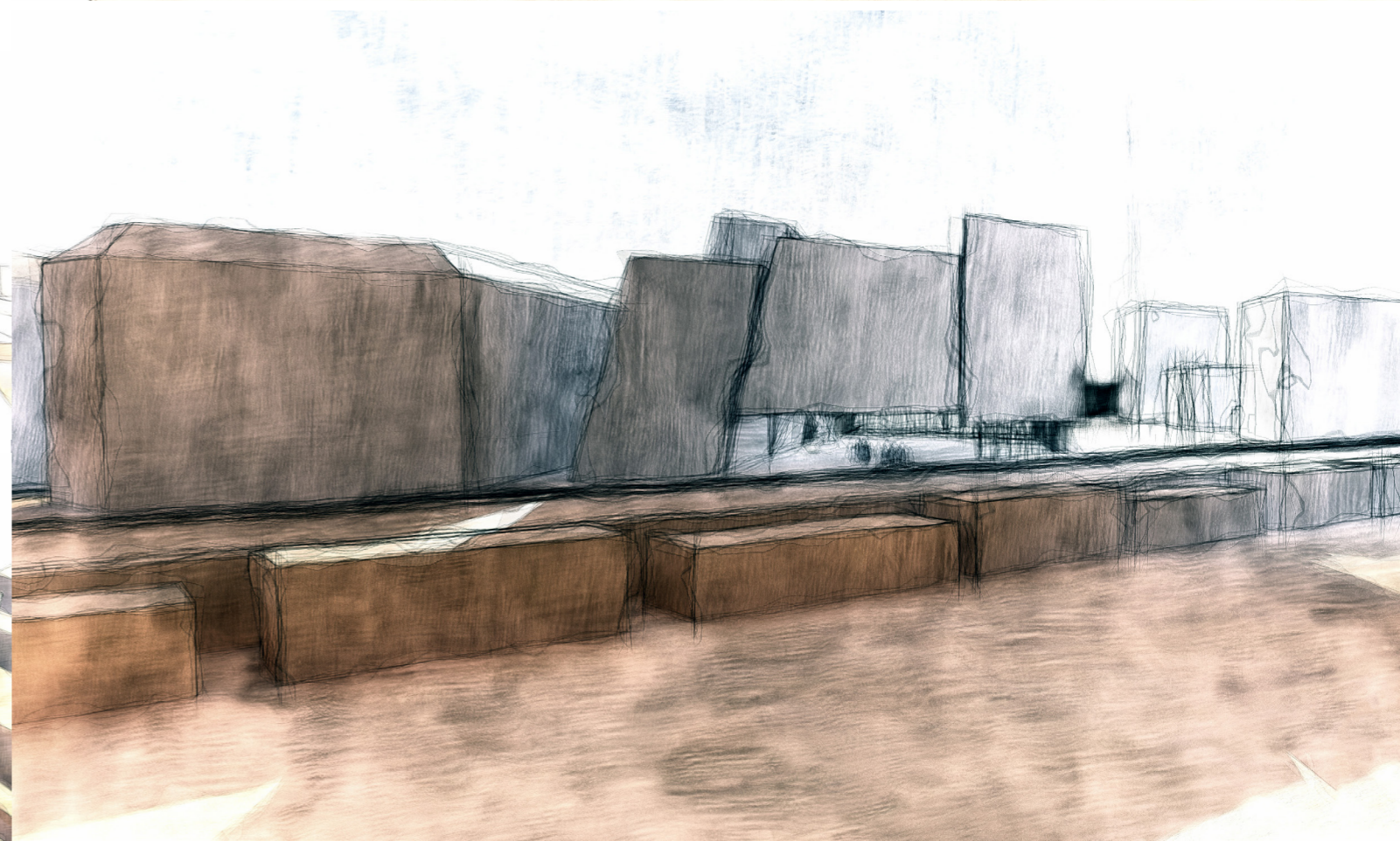
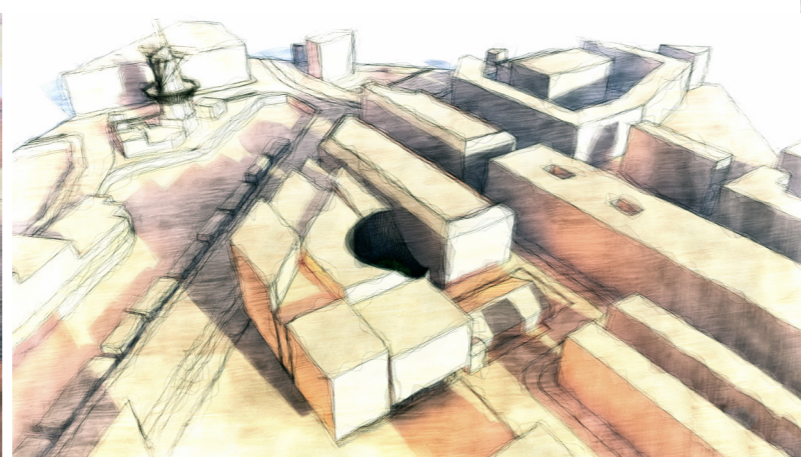
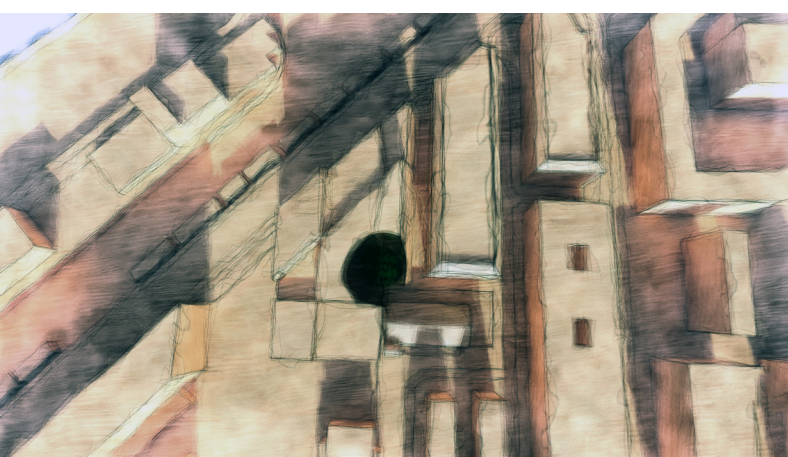
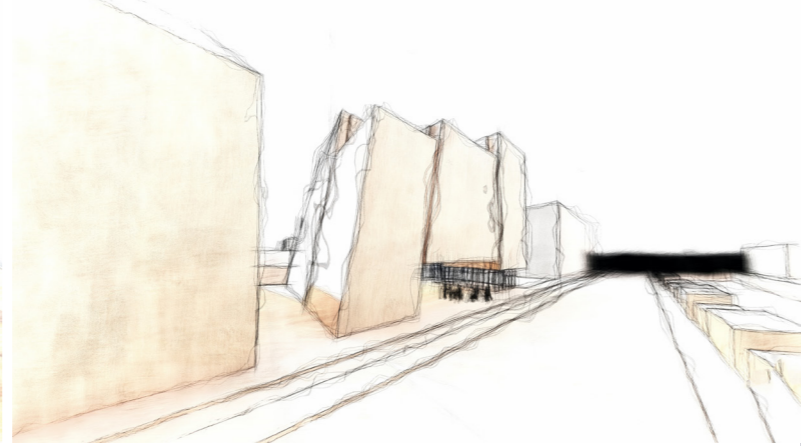
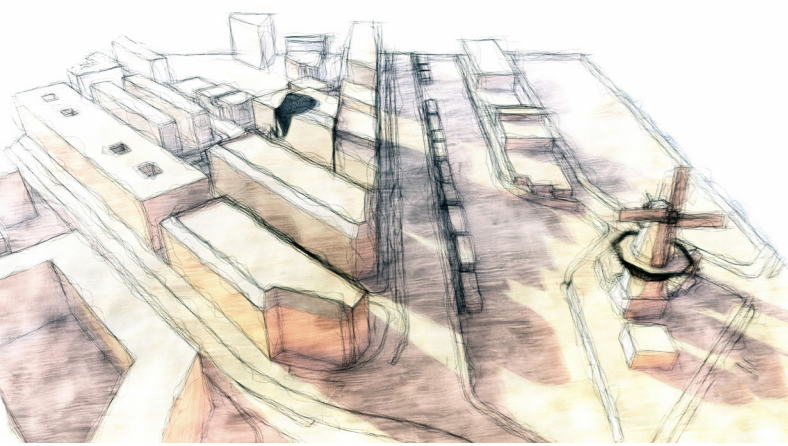
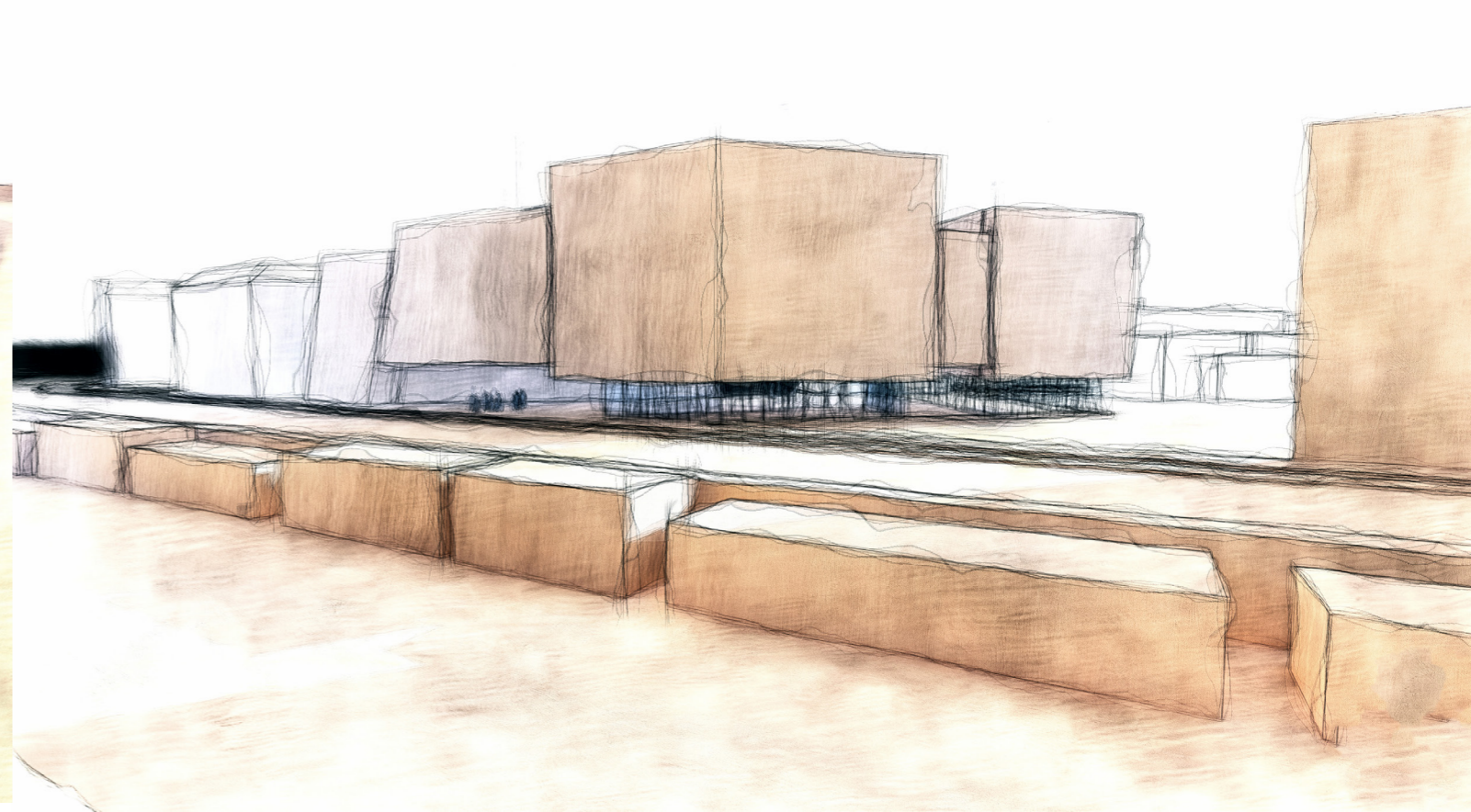
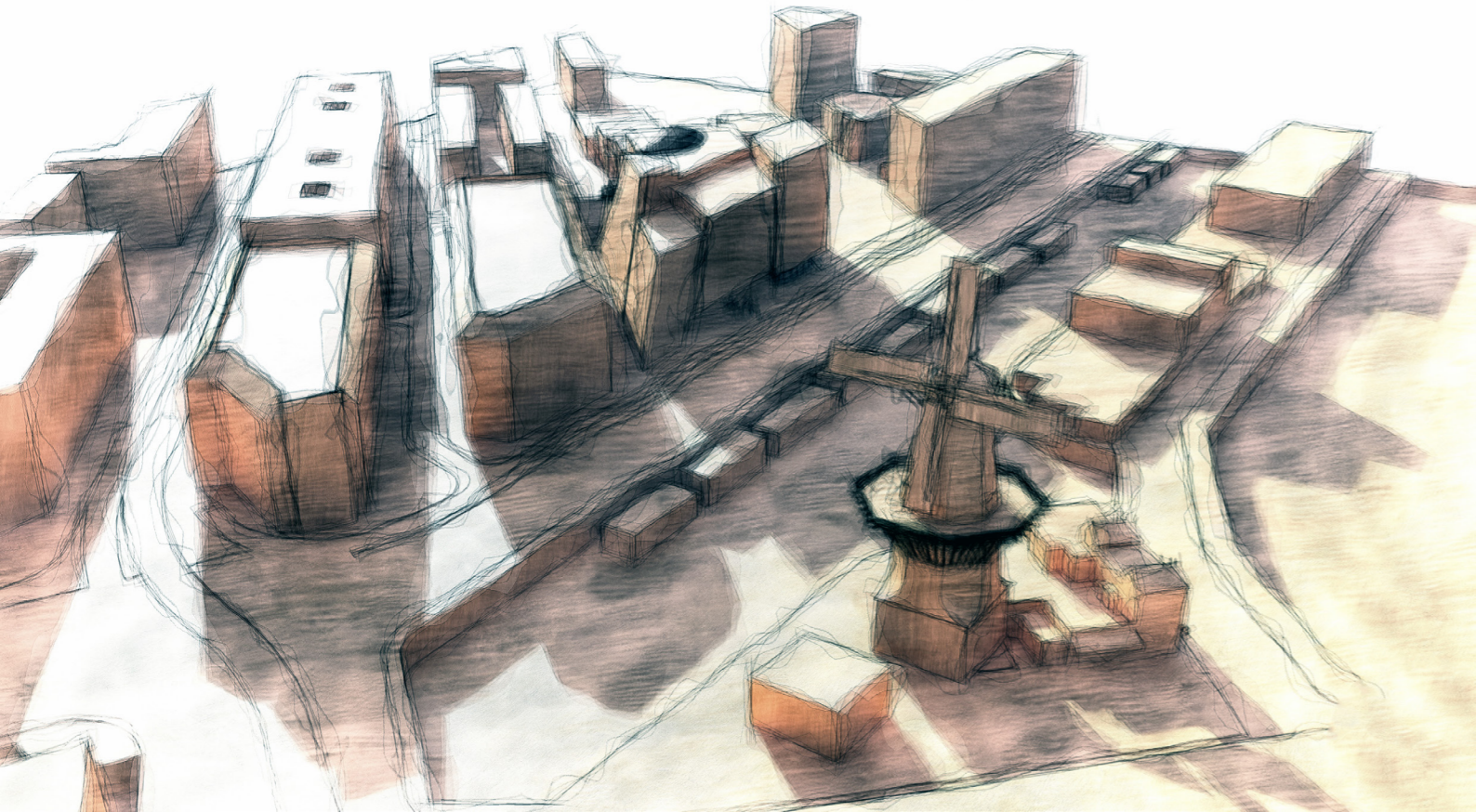

STUDY MODEL

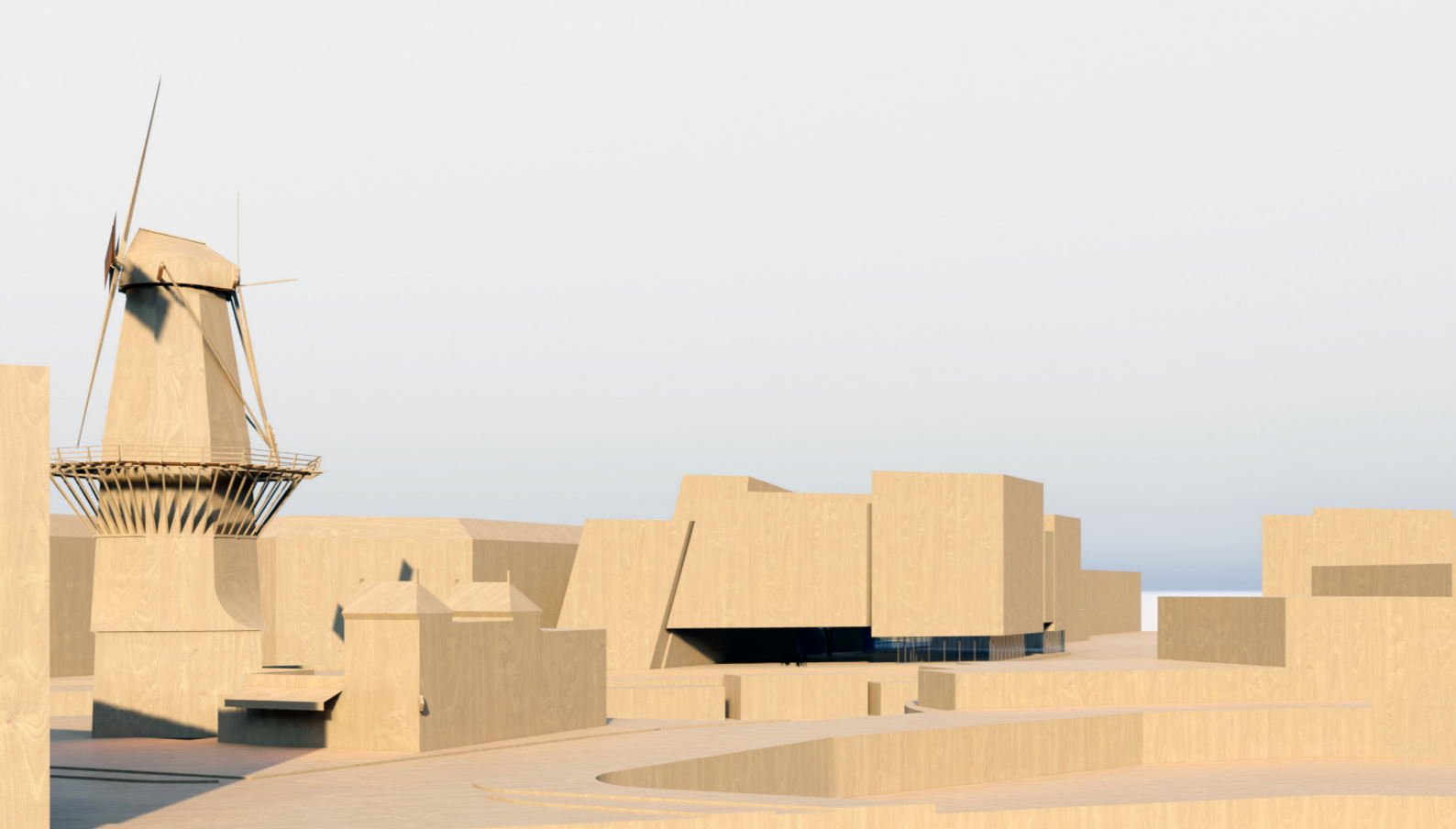
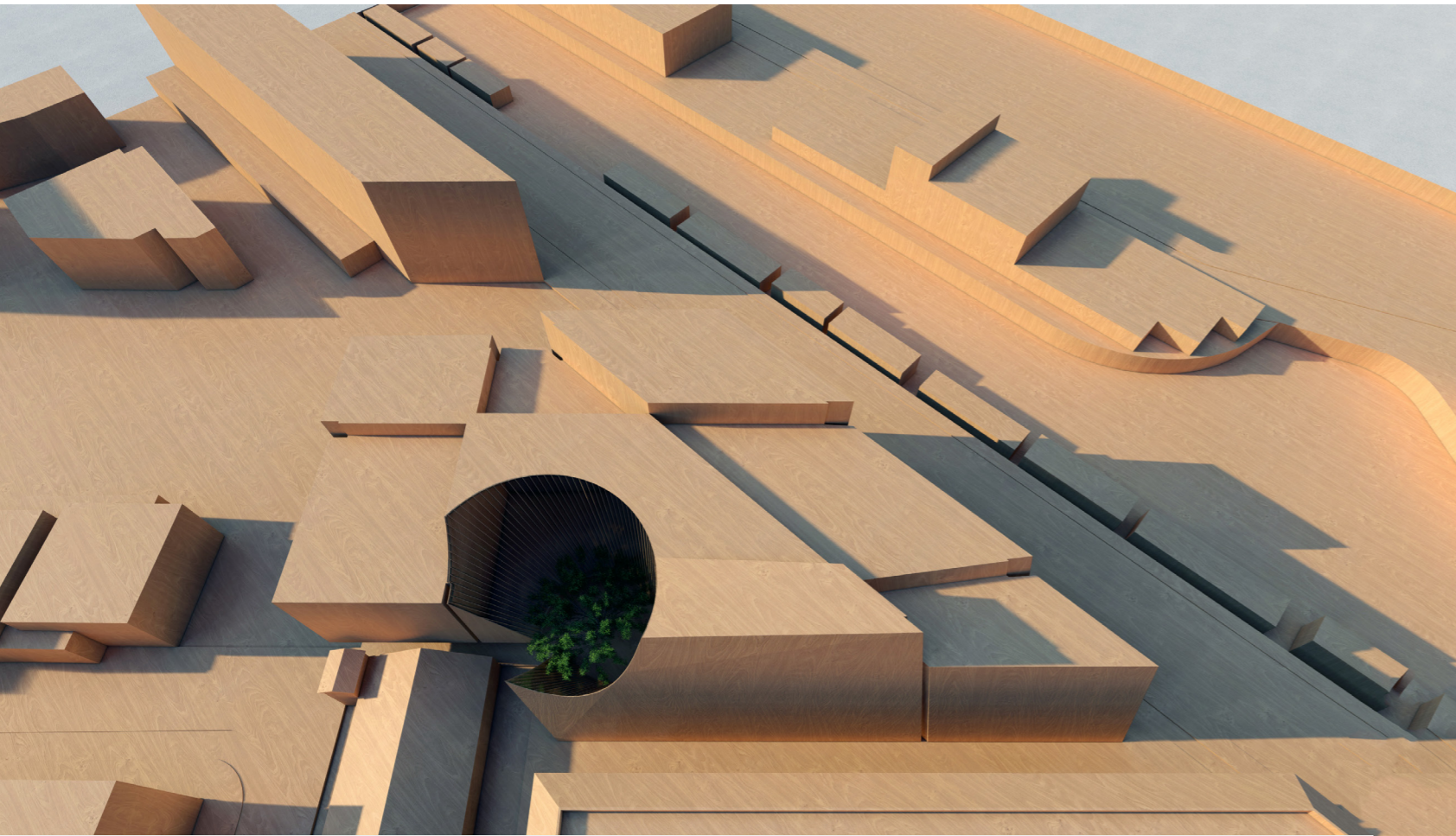

TECHNICAL INFORMATION OF ICH COMPLEX

4

The 2500 sqm site of the ICH Complex planned in Czaar Petersbuurt, in a vacant plot right beside the Funnenpark and it is to be constructed on the closest point of the approaching street to the site that is planned to be part of the park.

There is relatively a quiet street network around the site due to the residential park of

Funnenpark, though it is a great potential to create this integral community center to meeting variant young innovatives and talents. The problem with this street network is not that it is a quiet one, but actually it is a narrow one, although it could be pointed out as a weakness due to the hassle it brings to mobilization, the site of ICH itself could be very easily accessed since it will sit on the edge of the park, where there is plenty of complete openness and space, although it will have a fence during the process of construction, but the huge plane around it, clean off any built structures, will be in turn an easements for all the construction activities to be clearly and comfortably laid out on the site, from the bench marking Total Station to the bench marks of the to-be-built structures, offices for the PM, staff rooms, and their waterclosets, the workshop and fabrication areas to even the machinery parking (the transportation trucks) and the guard room as well. The new structures' infrastructure must be added and connected to those of the surrounding sites of the project, from a main drinking water supply line branch, and sewage network, let alone the power lines, and telecommunication lines. That from the perspective of the construction management.

To discuss the technical information of the buildings themselves, the footprint of the new structure is erected up to 5 floors. The finishing is to be of futuristic steel sheets cladding over the insulated RC walls. To speak of the function of the project is to serve the ICH, and its community integral purposes, the design proposal is composed of two existing Hangars, that are to be renovated and remodeled, and adding two masses to serve the purposes of entertainment, relaxation, and administration to the visitors and the project's

and/or site's users. The Activities of entertainment and relaxation is housed by spaces of restaurants, cafes, small pools, sauna, showers, changing rooms, resting area, congregation areas, lobbies offices, workshops, lecture halls and storages.

All the details of the finishings as well are added in a table to Annex E along with the site plan and other drawings of the project.

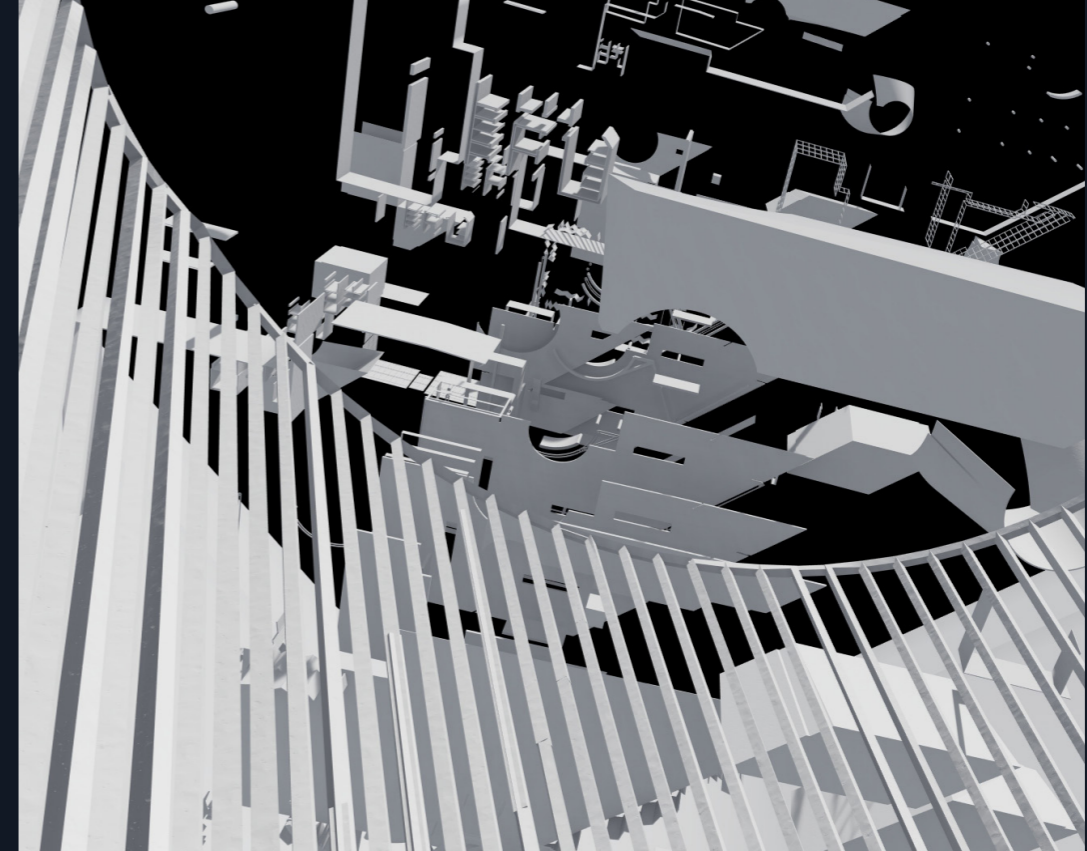
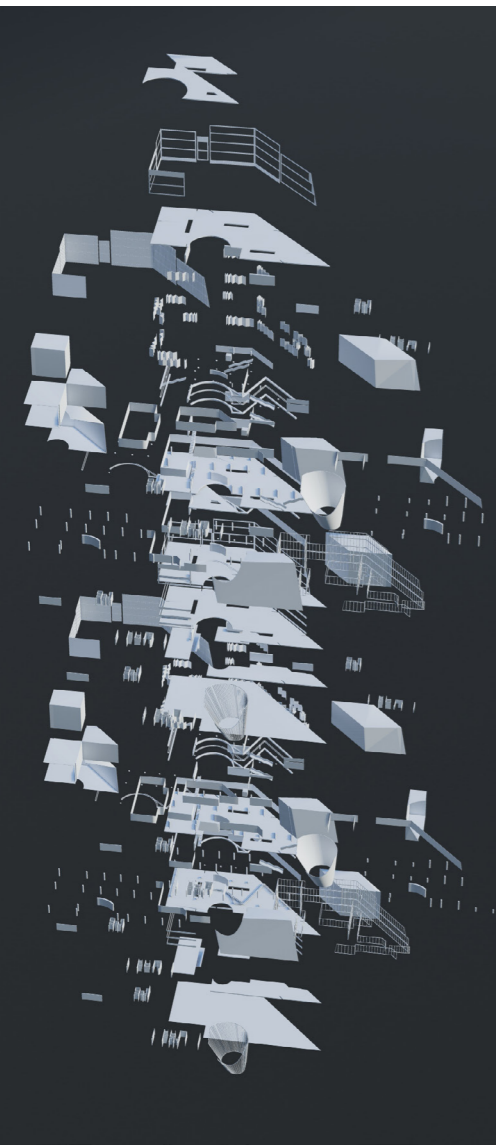

FINISHING MATERIAL LIST (FACADE + ROOF)

1. Steel Sheets over the insulated RC walls for the exterior finishing
2. Recycled Thatch Looking Interior Finishing
3. Green Roof + SunPower Photovoltaic Solar Panels
4. Double railed folding/dynamic steel skin articulating the Breeze Out.
5. The curtain wall behind the folding steel sheets is composed: Double Cardinal 272 coating, double argon, double super spacer, steel framed smart glass of 10 cm width (Sound- and Thermal- Insulating Triple Glazing)

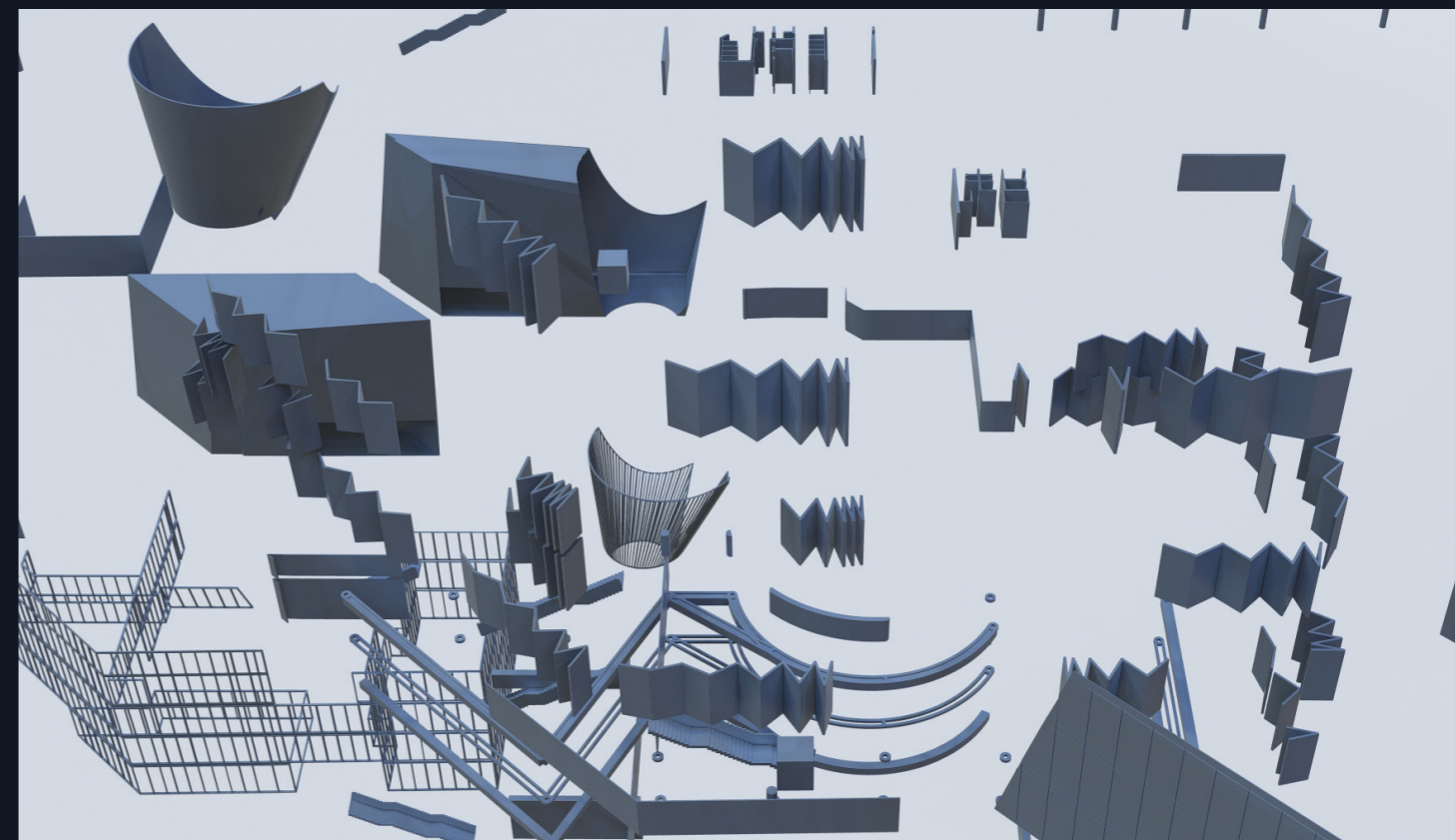

FURNISHING LAYOUTS

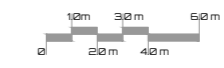
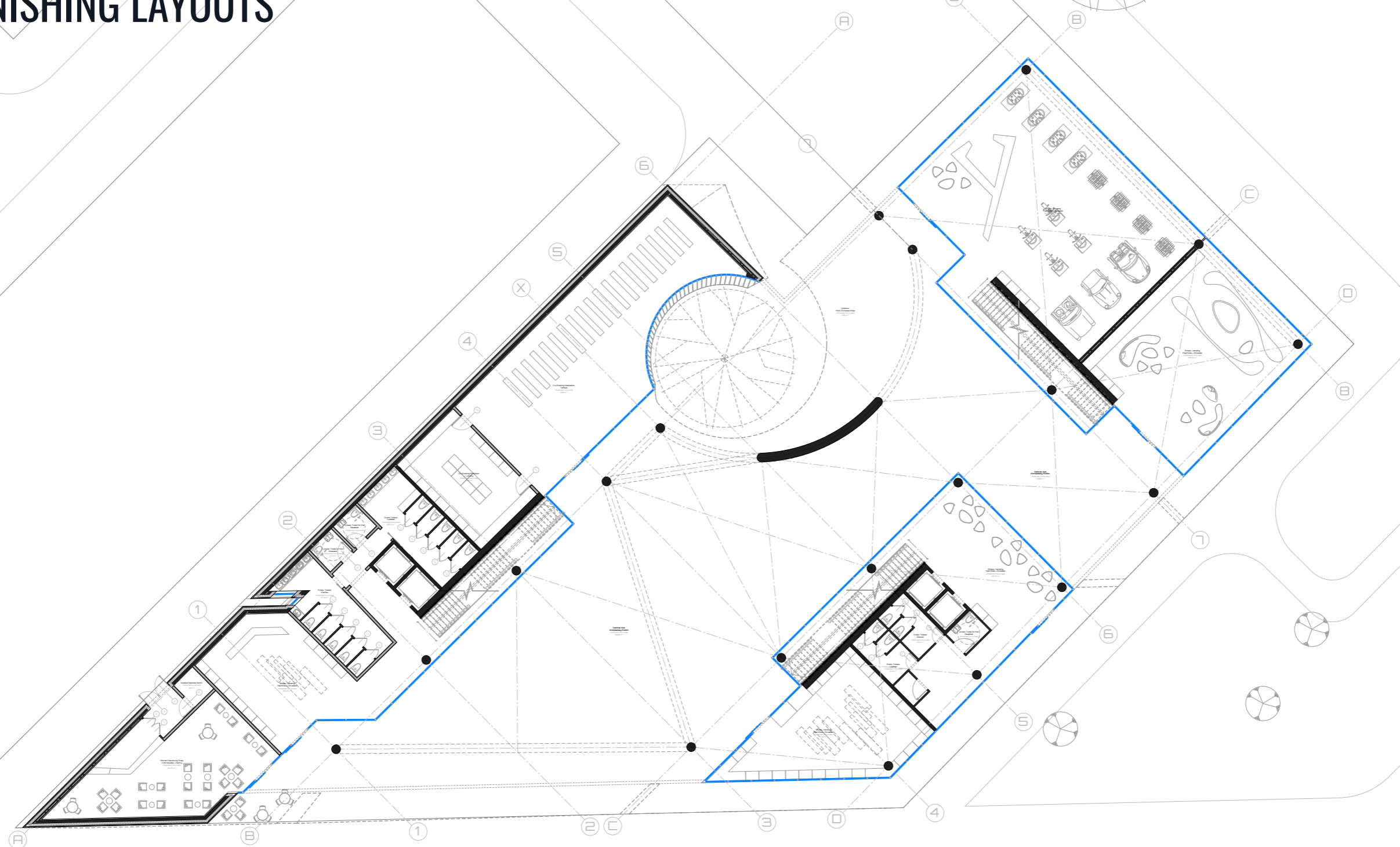

GROUND FLOOR LAYOUT
ICH: INTERNATIONAL COMMUNITY HUB

FURNISHING LAYOUTS

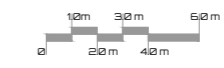
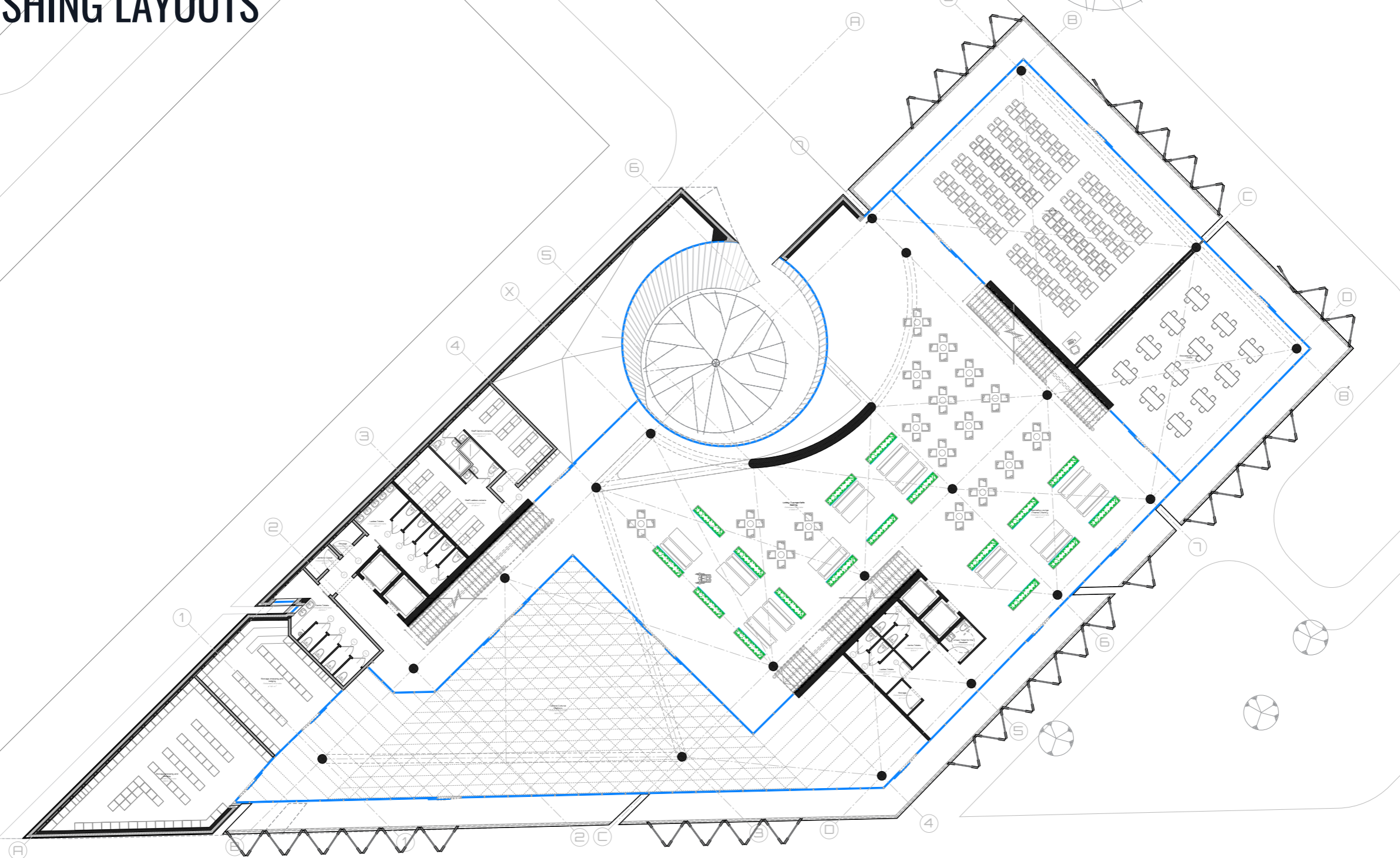

FIRST FLOOR LAYOUT
ICH: INTERNATIONAL COMMUNITY HUB

FURNISHING LAYOUTS

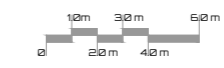
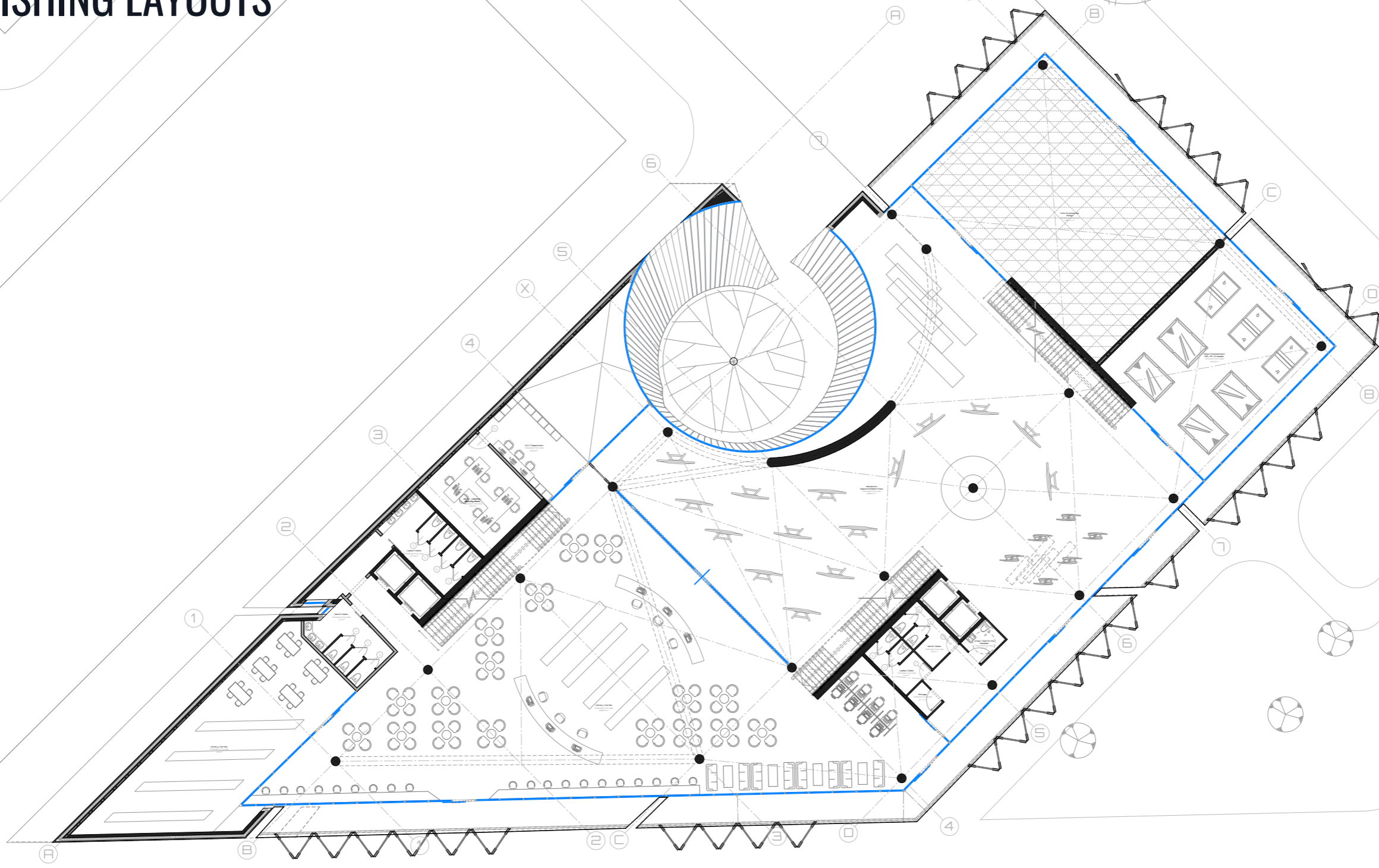

SECOND FLOOR LAYOUT
ICH: INTERNATIONAL COMMUNITY HUB

FURNISHING LAYOUTS

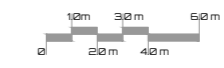
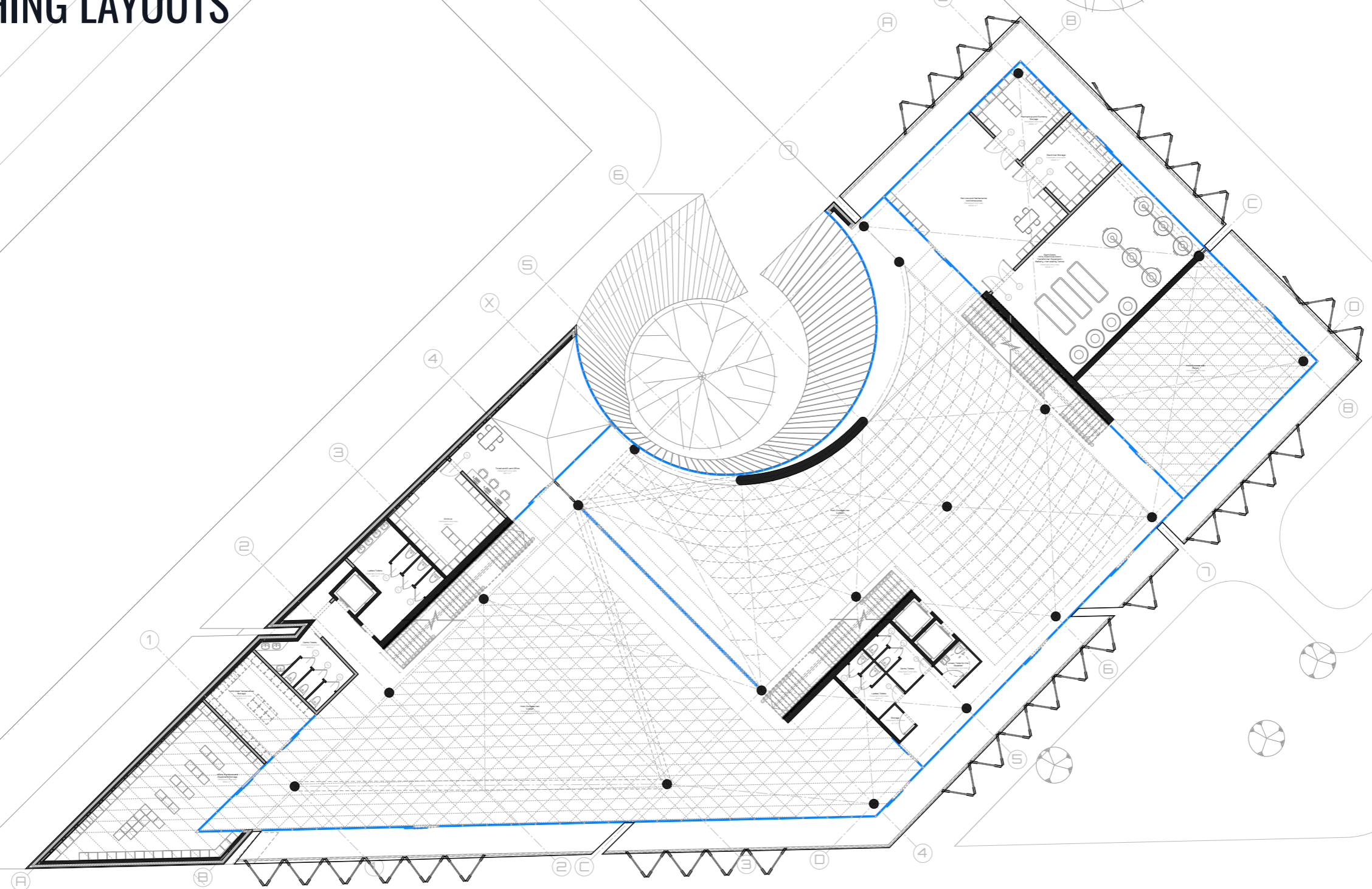

THIRD FLOOR LAYOUT
ICH: INTERNATIONAL COMMUNITY HUB

FURNISHING LAYOUTS

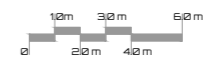
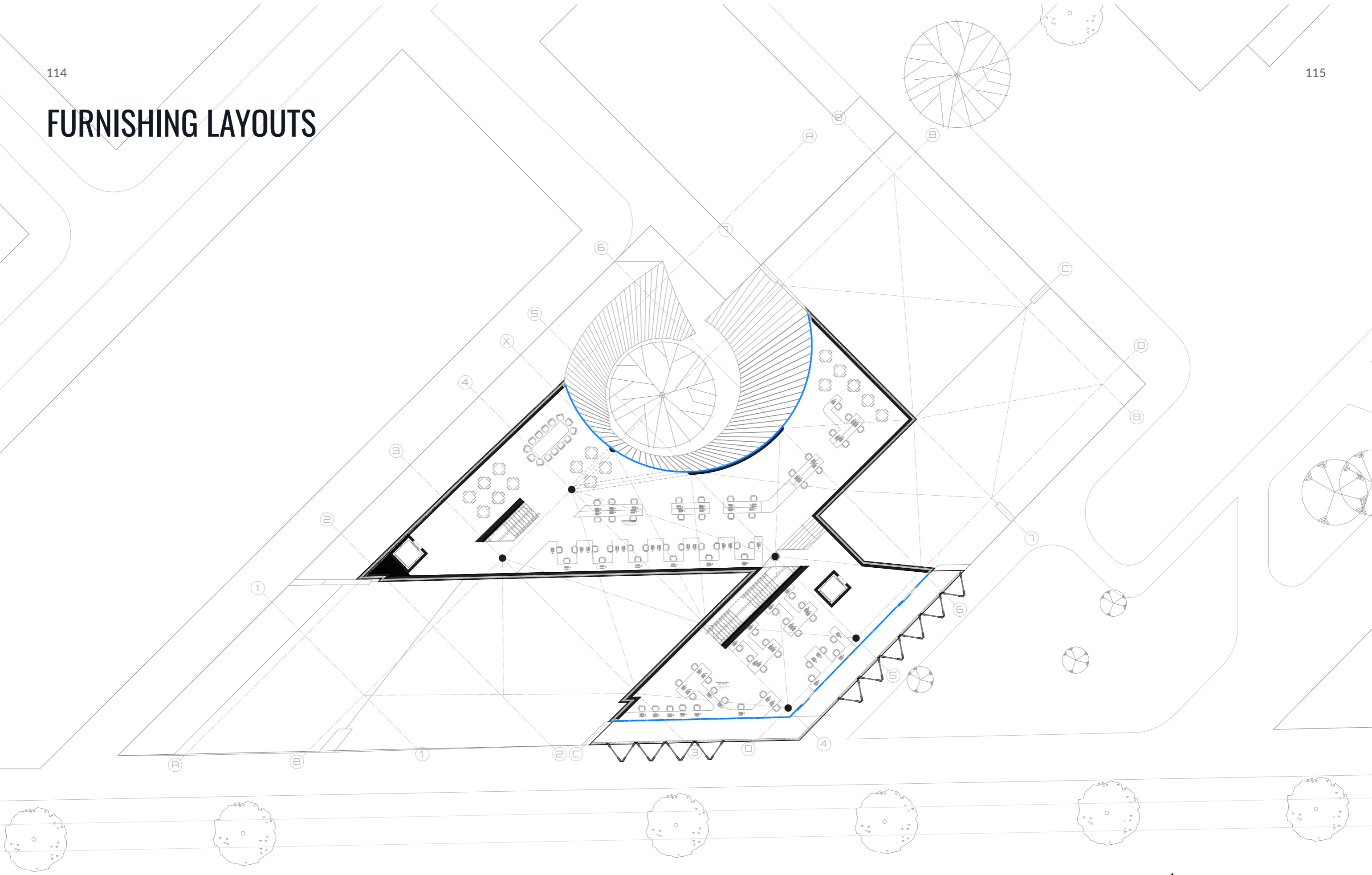

ARCHITECTURAL DRAWINGS

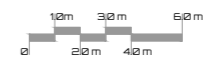
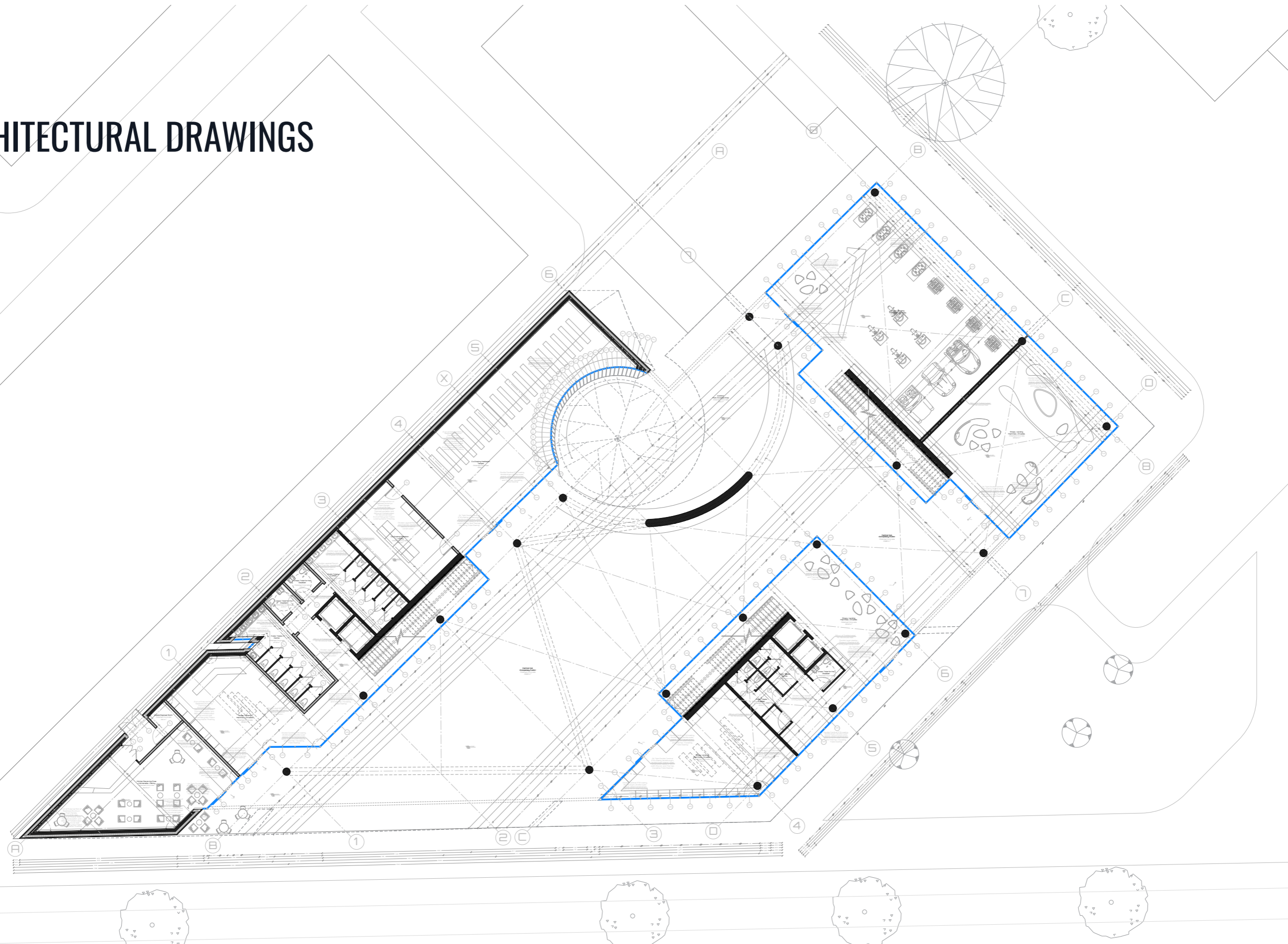

GROUND FLOOR
ARCHITECTURAL LAYOUT
ICH: INTERNATIONAL COMMUNITY HUB

ARCHITECTURAL DRAWINGS

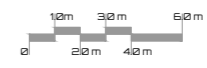
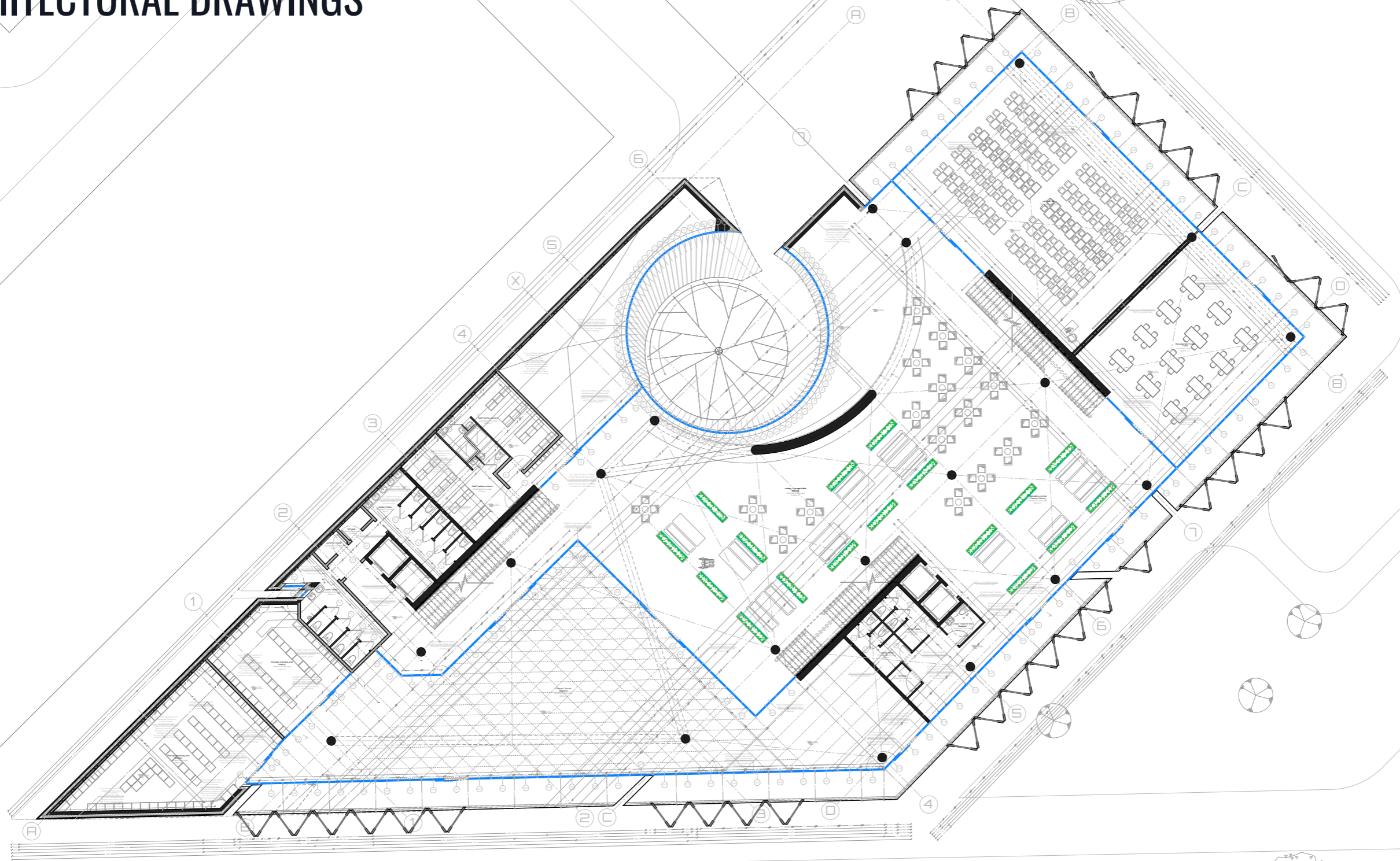

FIRST FLOOR
ARCHITECTURAL LAYOUT
ICH: INTERNATIONAL COMMUNITY HUB

ARCHITECTURAL DRAWINGS

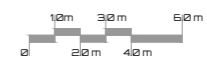
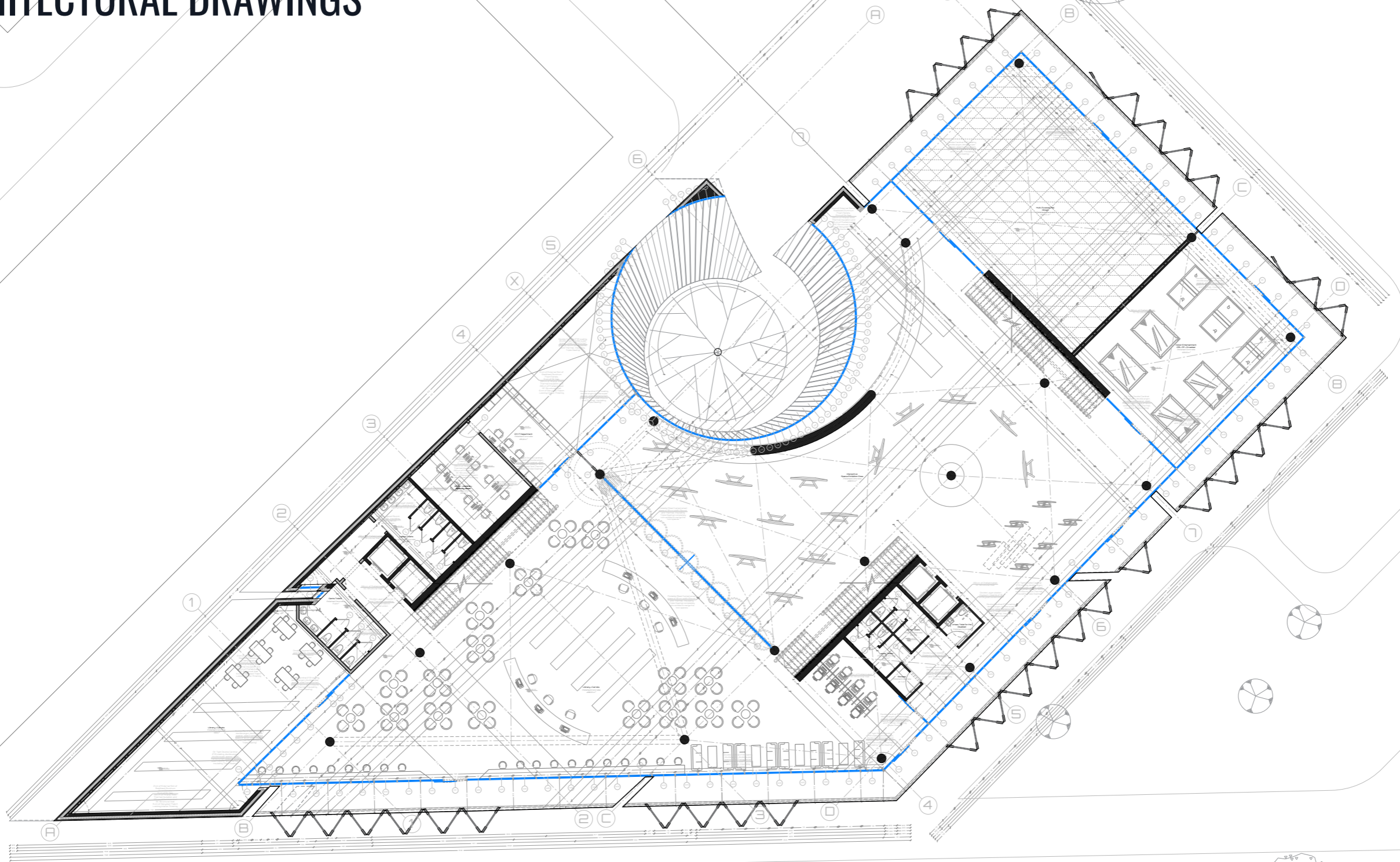

SECOND FLOOR
ARCHITECTURAL LAYOUT
ICH: INTERNATIONAL COMMUNITY HUB

ARCHITECTURAL DRAWINGS

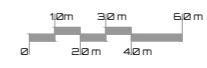
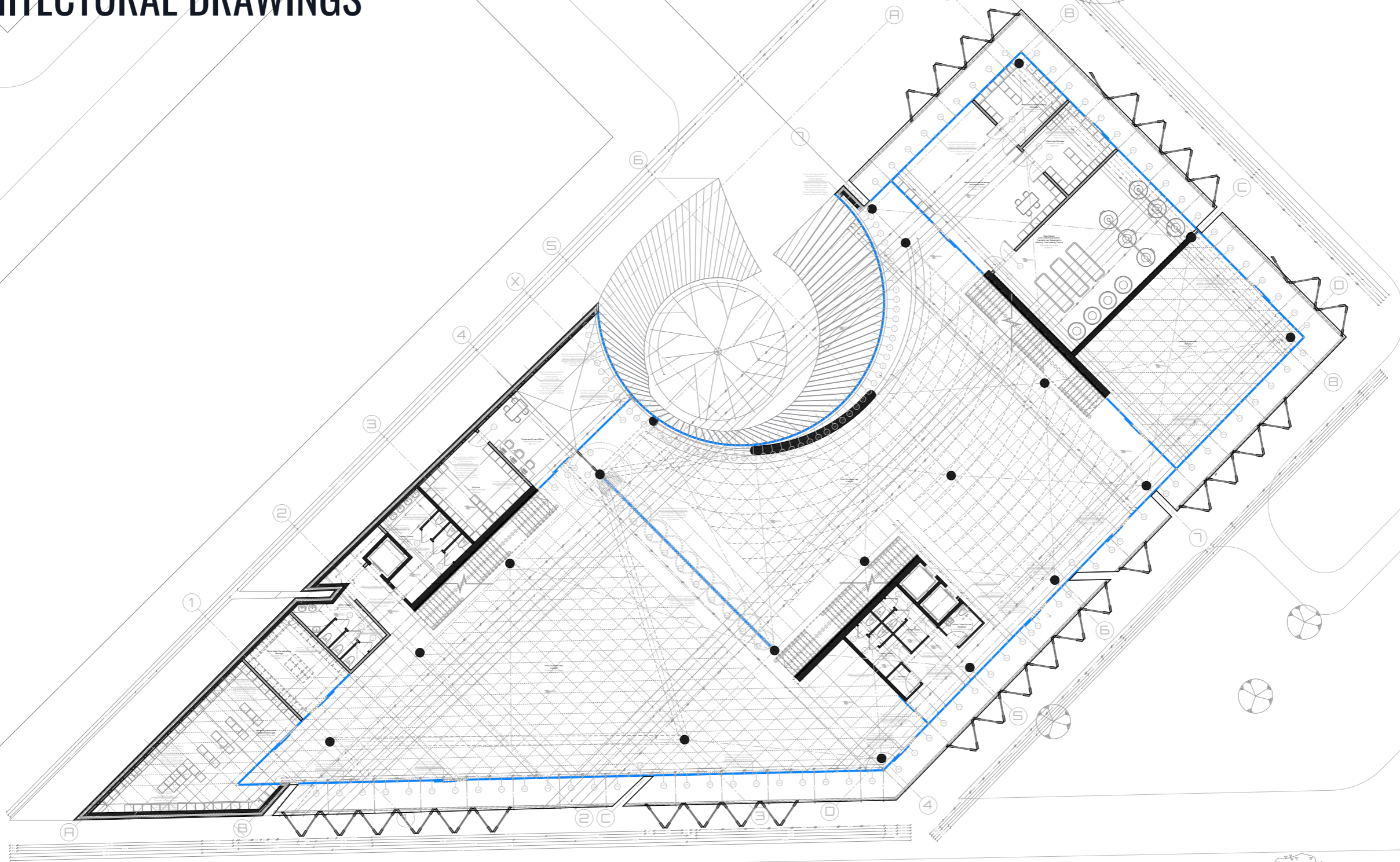

THIRD FLOOR
ARCHITECTURAL LAYOUT
ICH: INTERNATIONAL COMMUNITY HUB

ARCHITECTURAL DRAWINGS

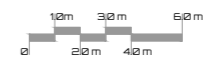
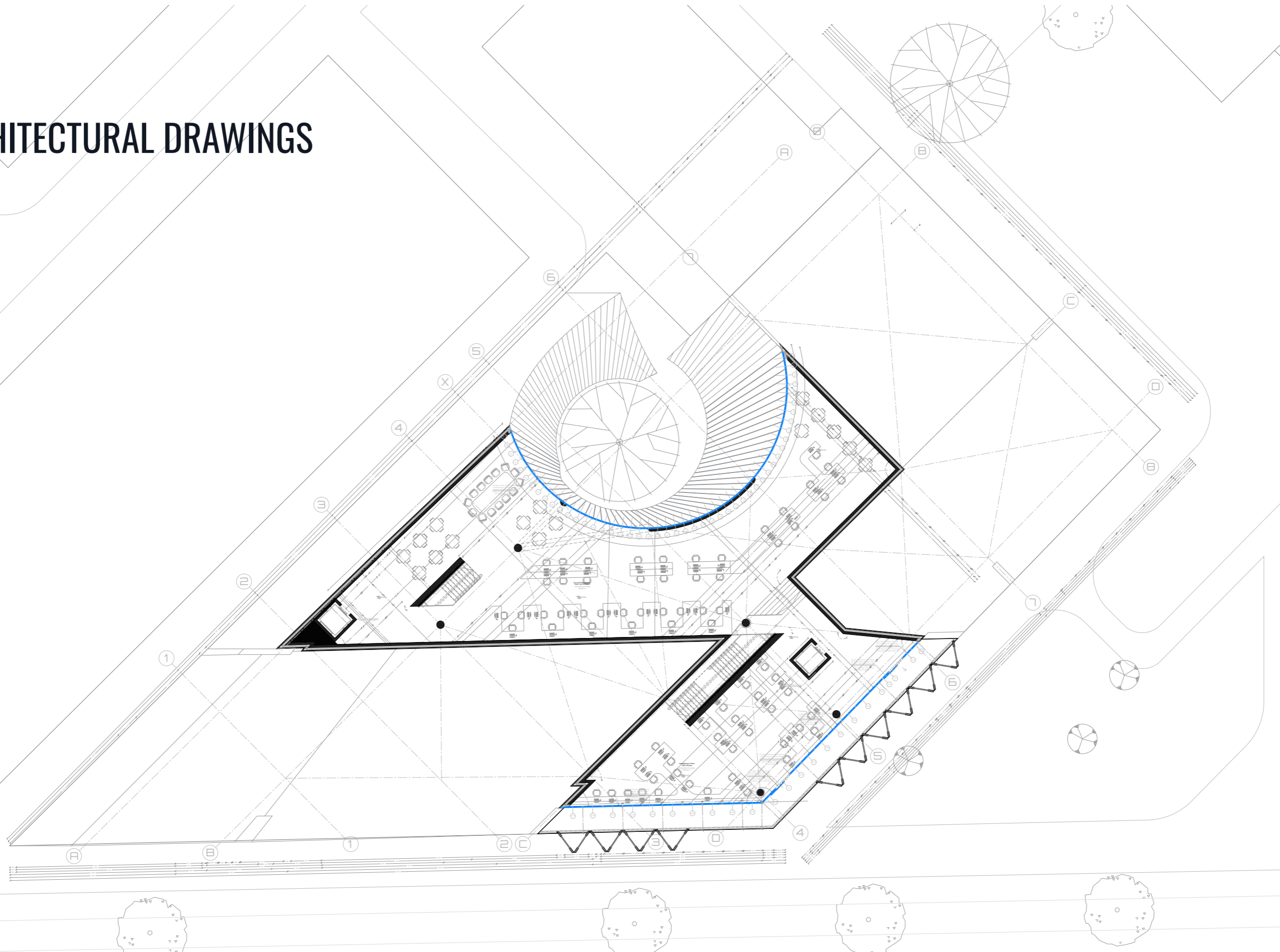

**FOURTH FLOOR
ARCHITECTURAL LAYOUT**
ICH: INTERNATIONAL COMMUNITY HUB

ARCHITECTURAL DRAWINGS

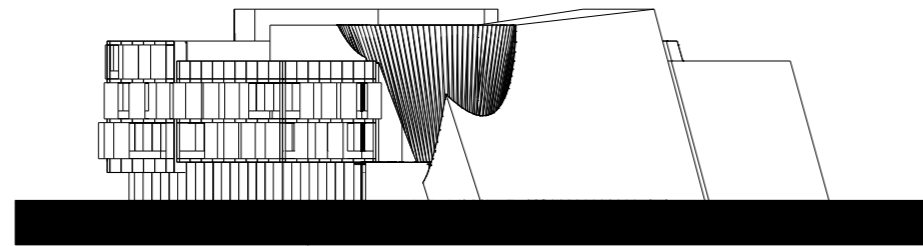

Northern Facade

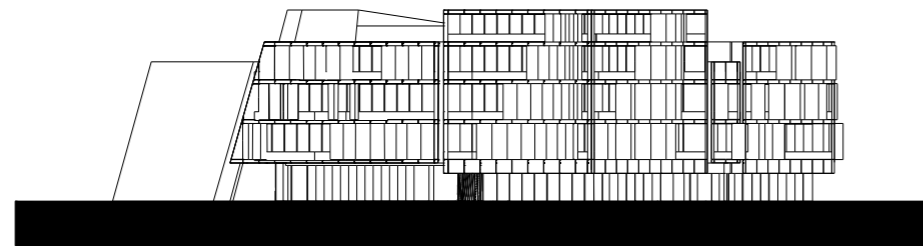
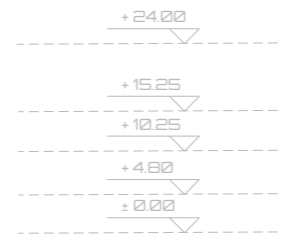

Southern Facade

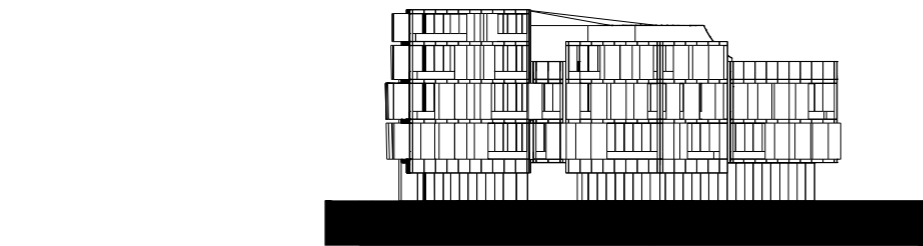
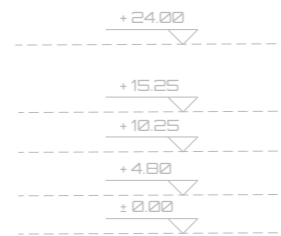

Eastern Facade

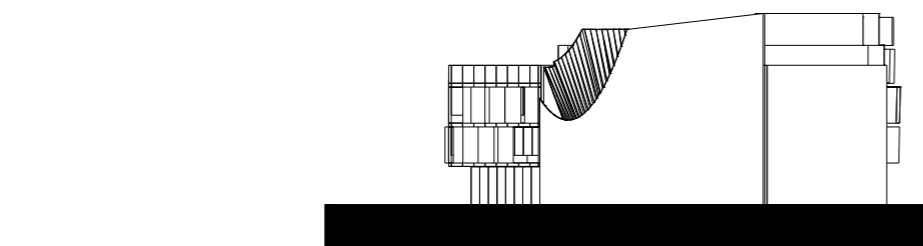
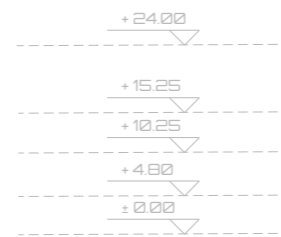

Western Facade

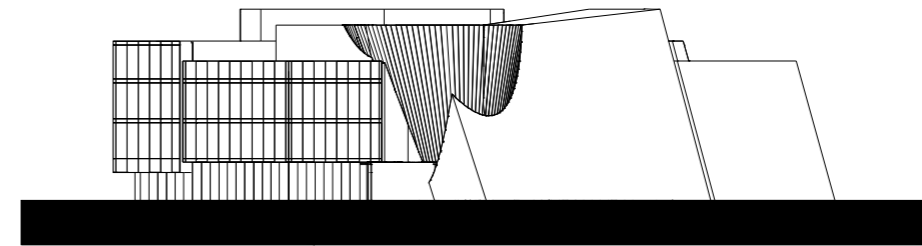
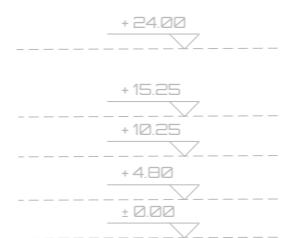

Northern Facade

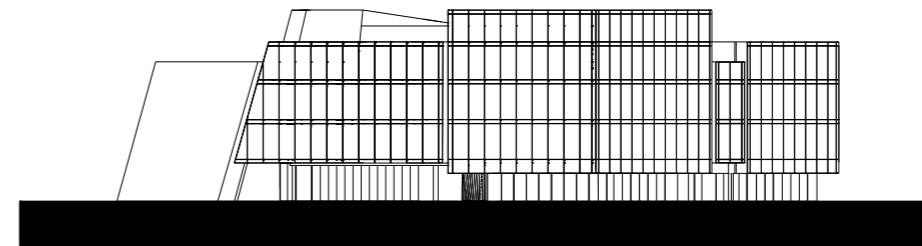

Southern Facade

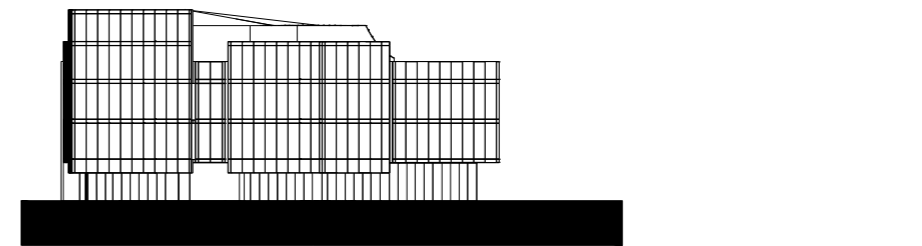

Eastern Facade

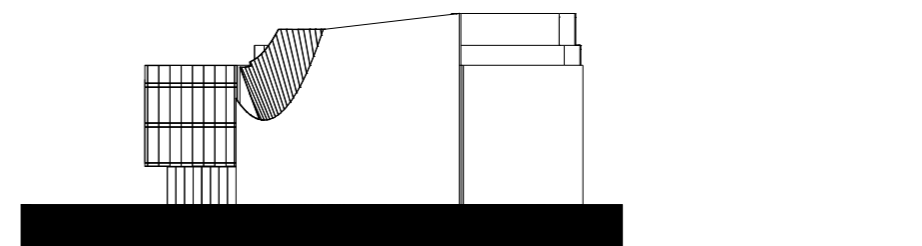

Western Facade

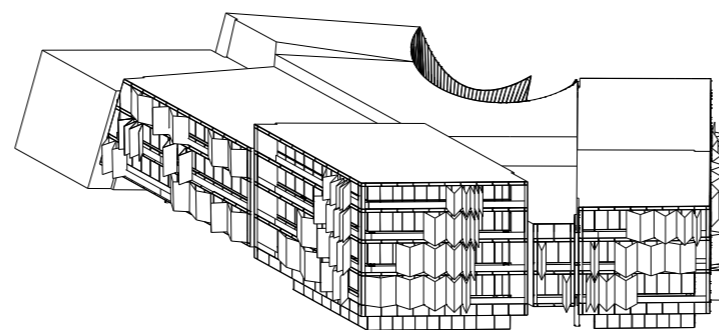

ARCHITECTURAL DRAWINGS

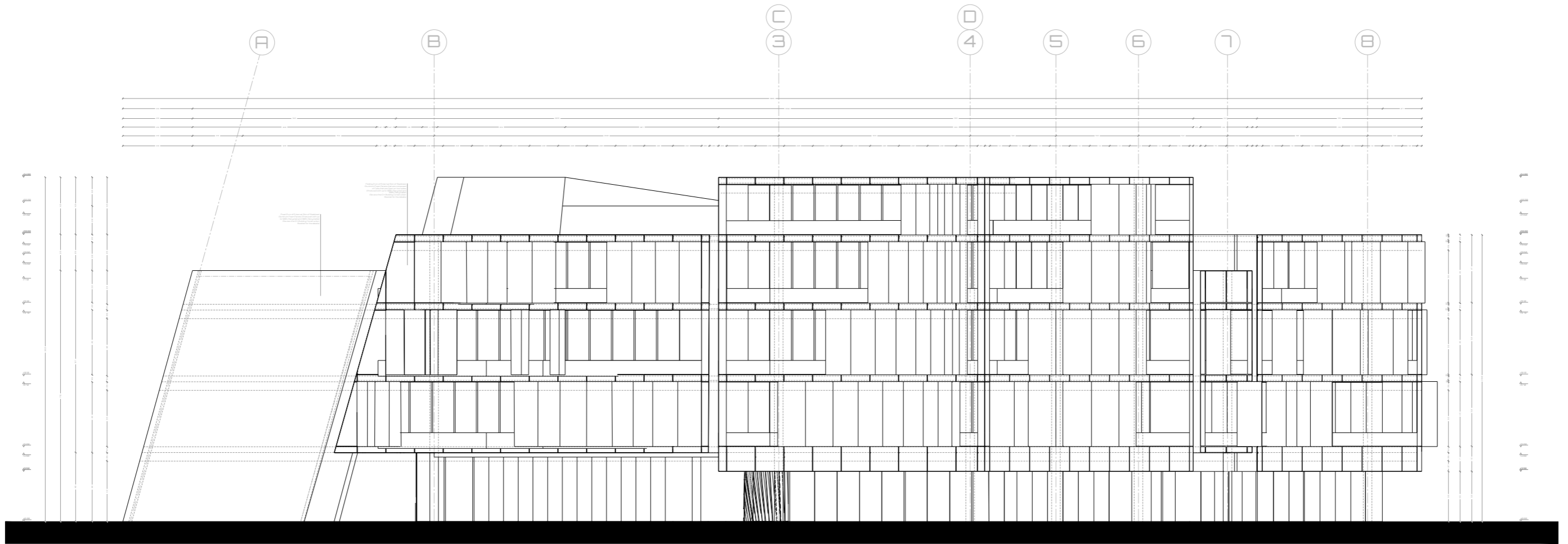
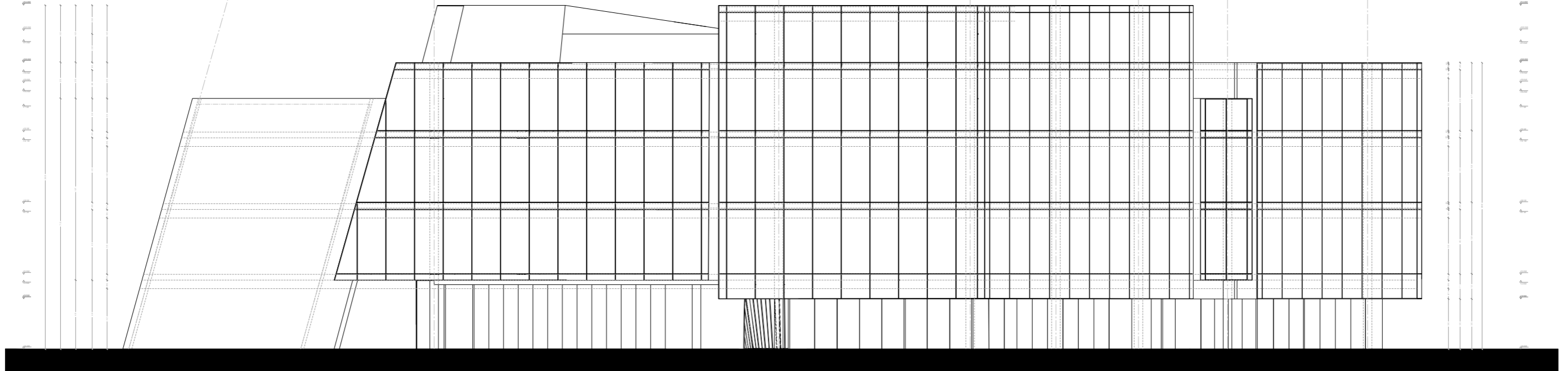

ARCHITECTURAL DRAWINGS

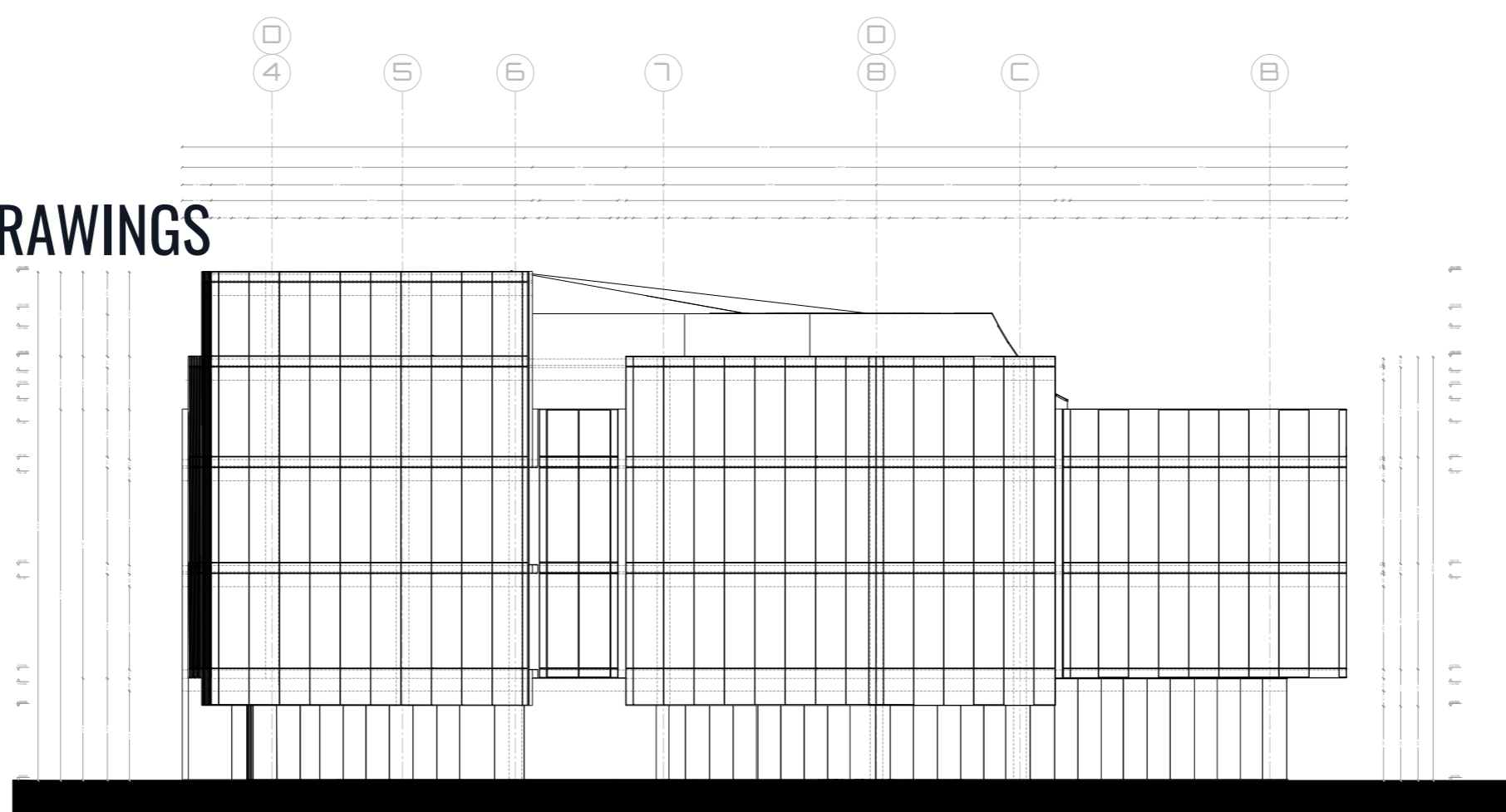

Eastern Facade
الواجهة الشرقية

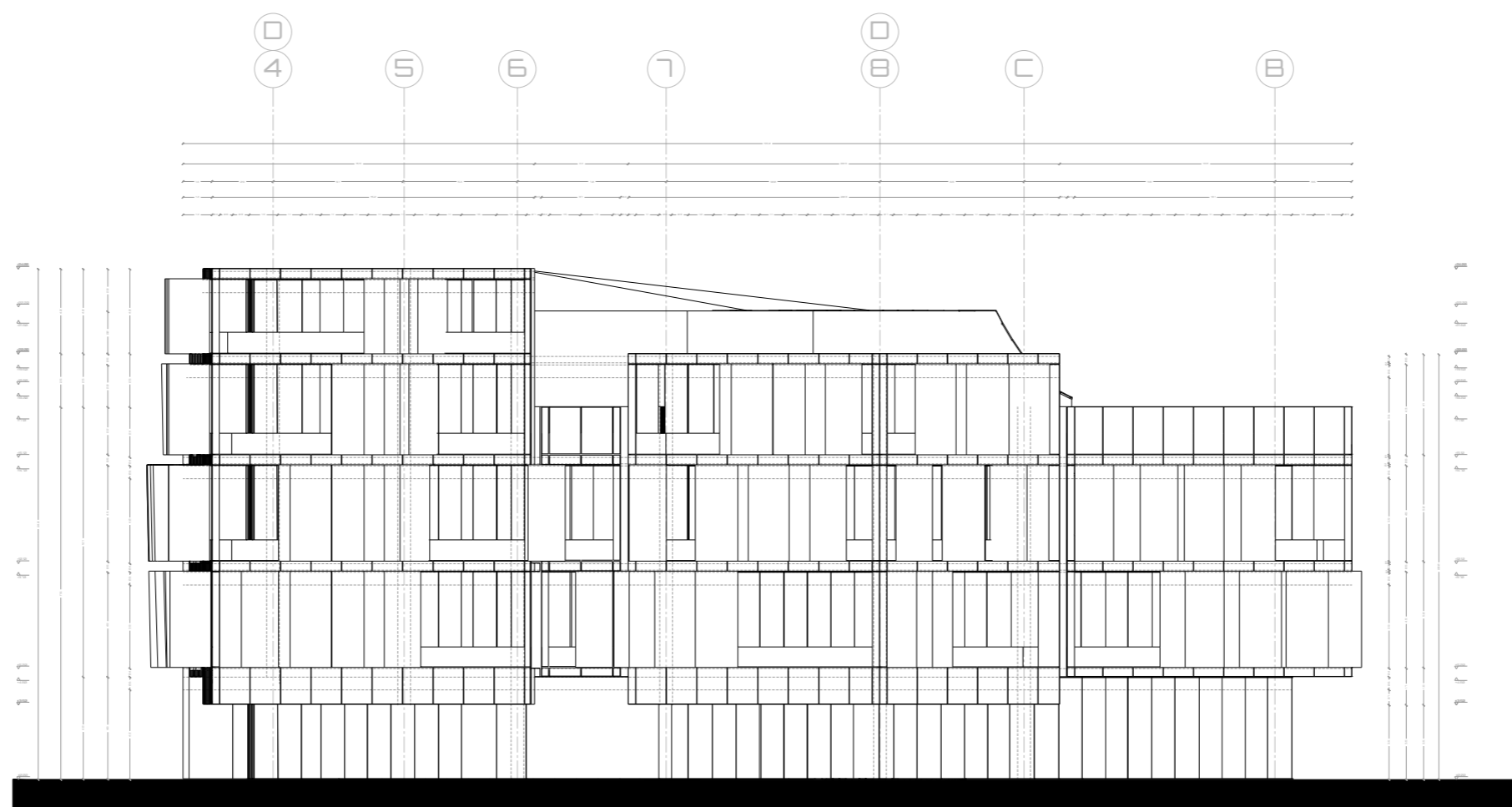

Eastern Facade
الواجهة الشرقية

ARCHITECTURAL DRAWINGS

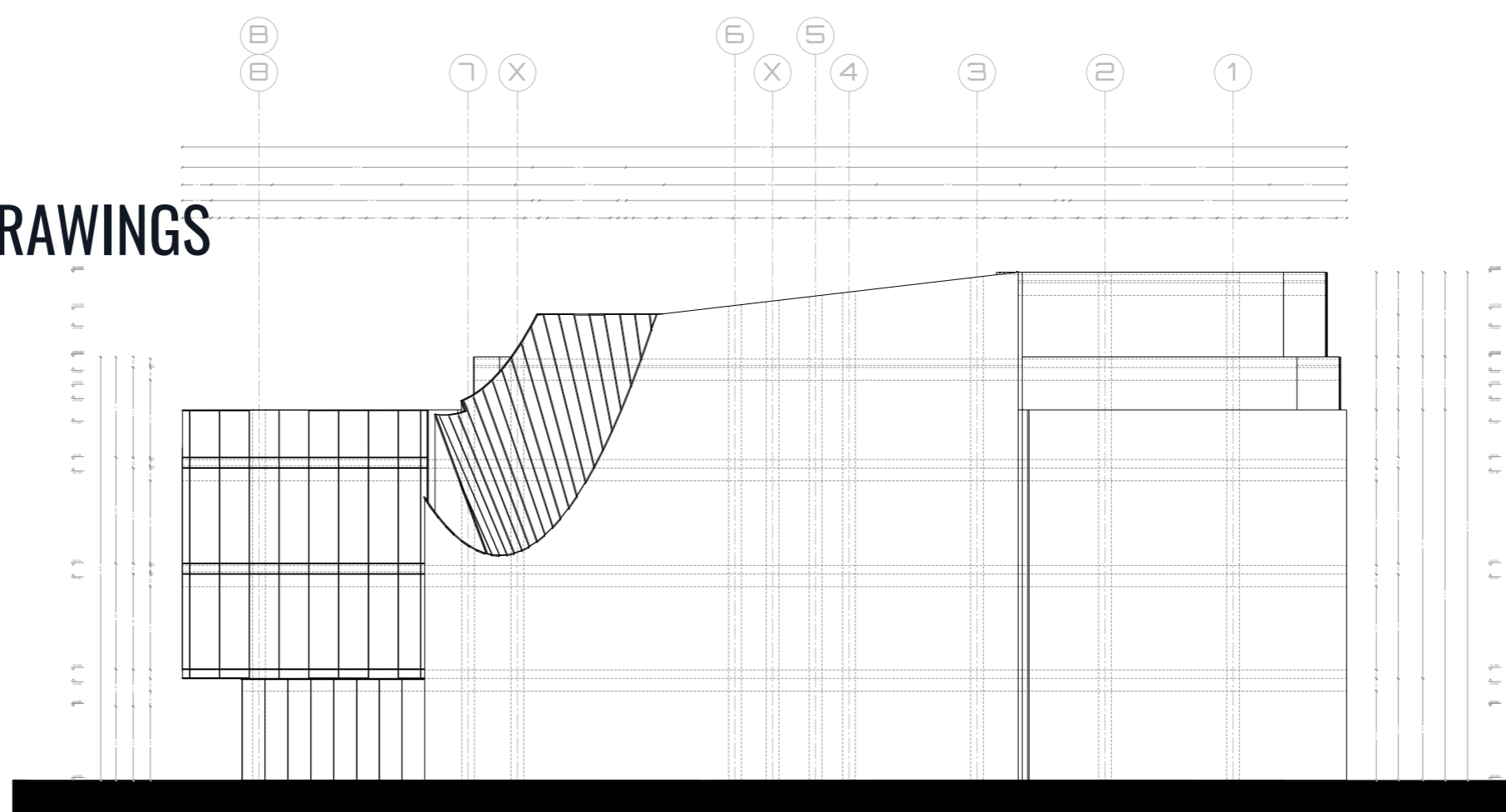

Western Facade
Architectural
[Logo]

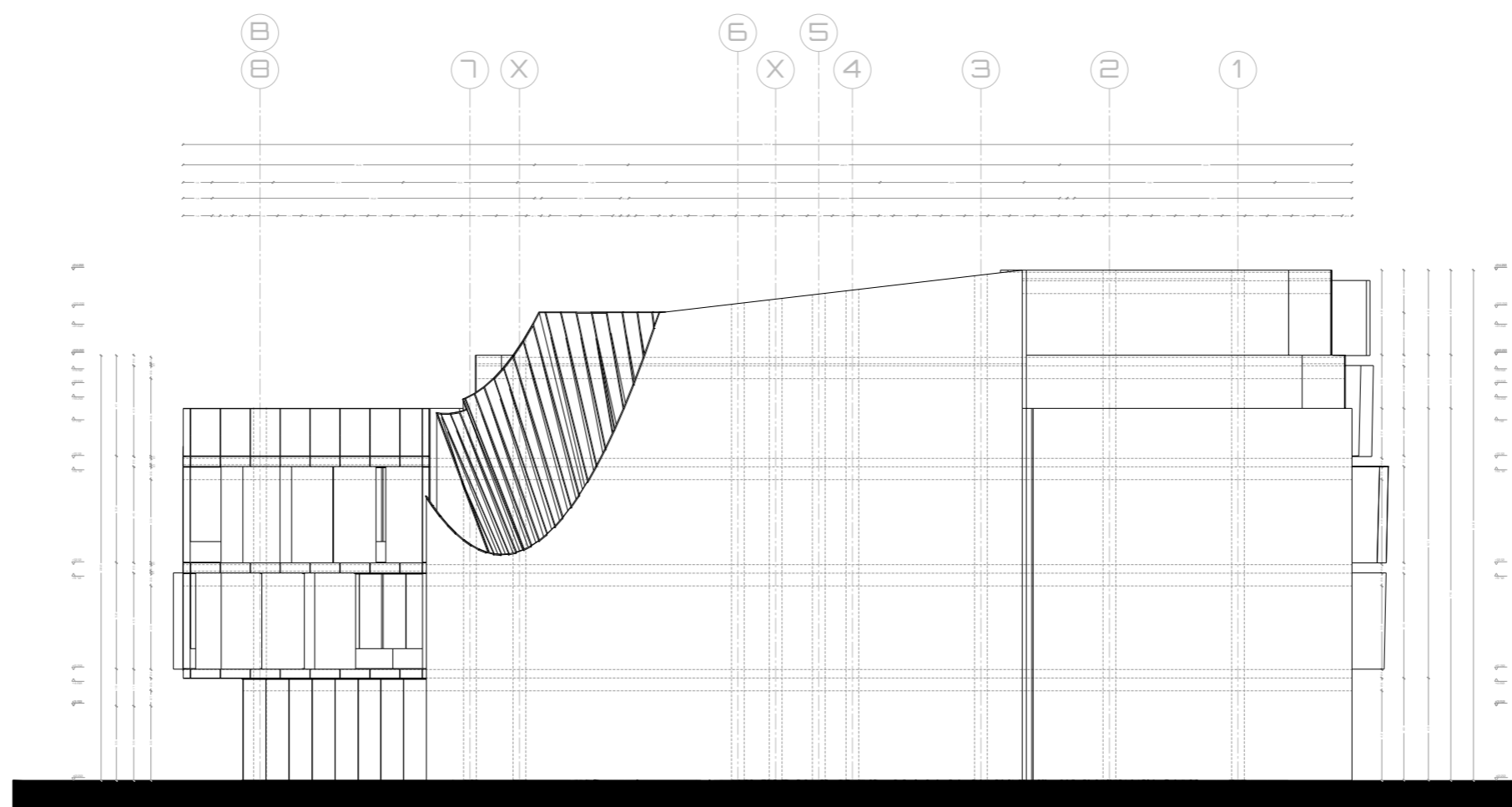

Western Facade
Architectural
[Logo]

ARCHITECTURAL DRAWINGS

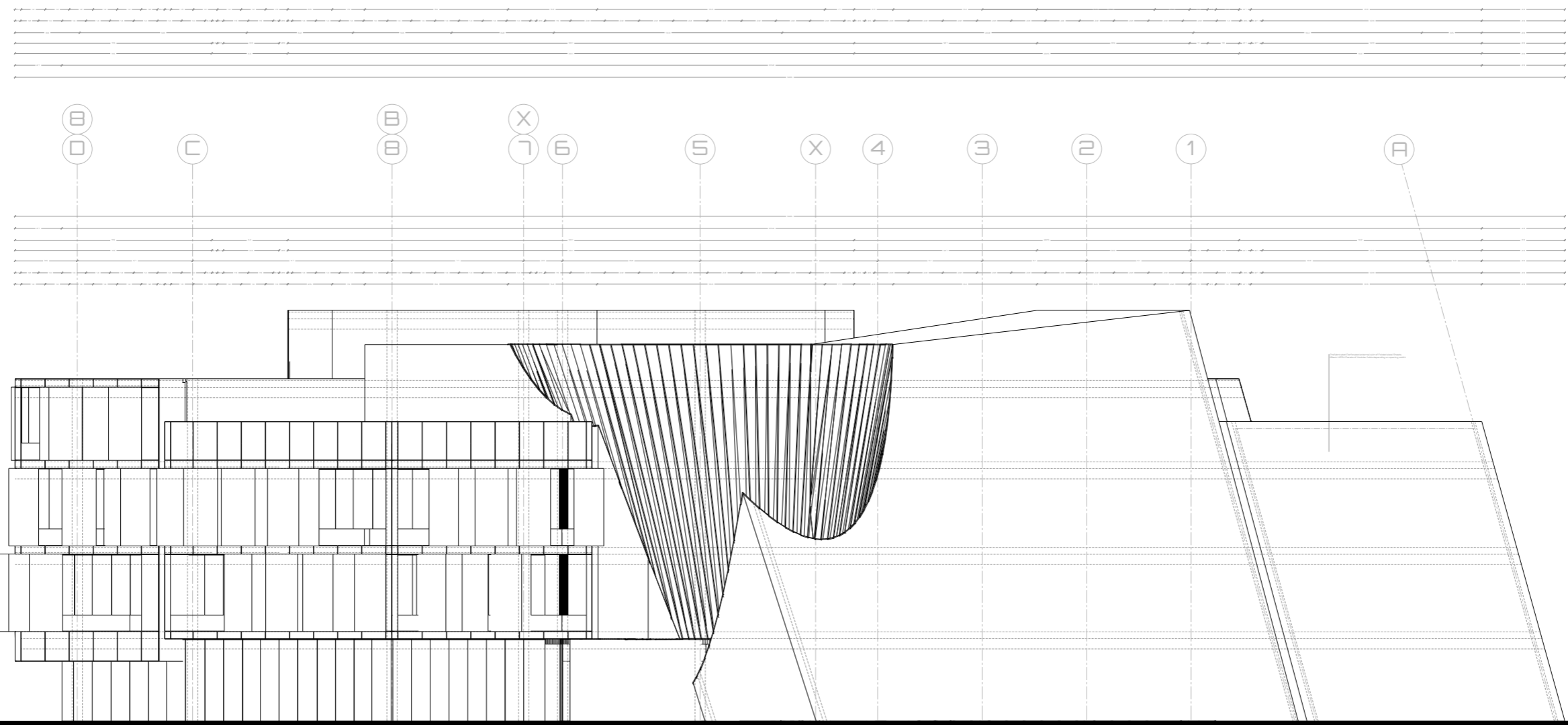
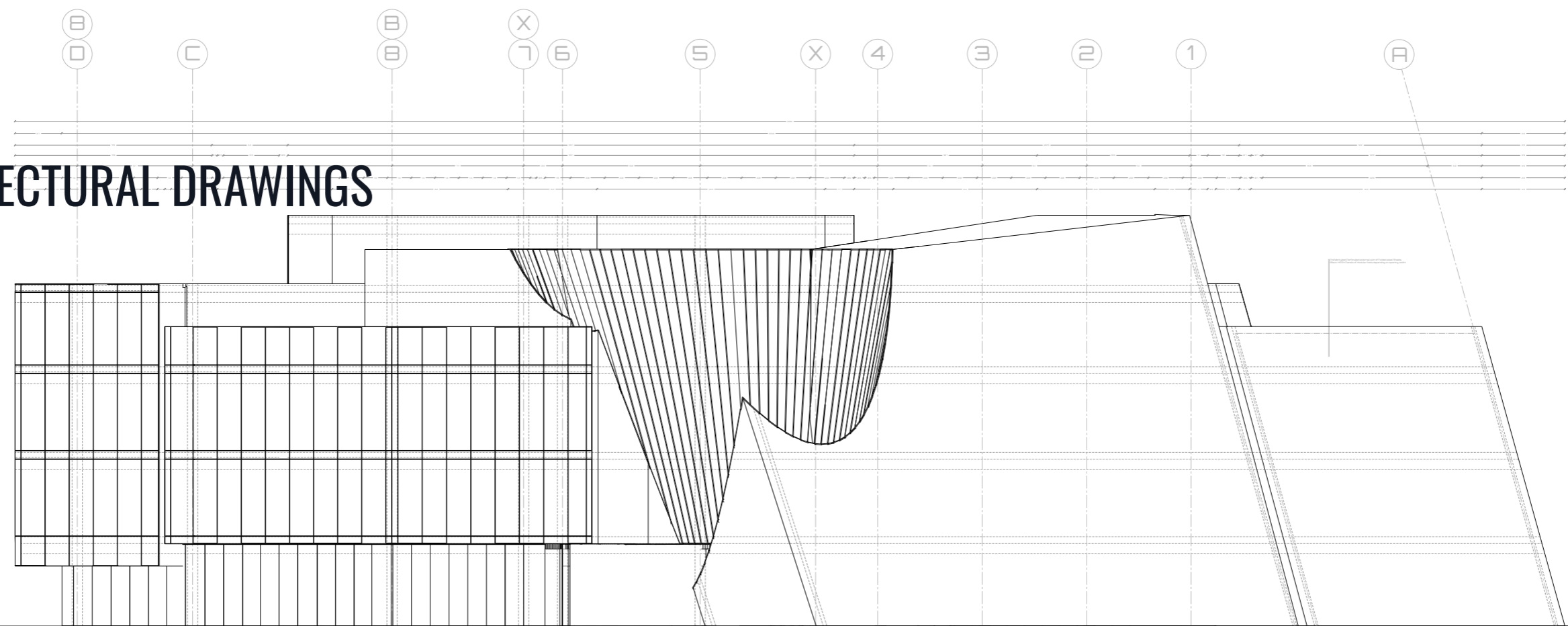

ARCHITECTURAL DRAWINGS

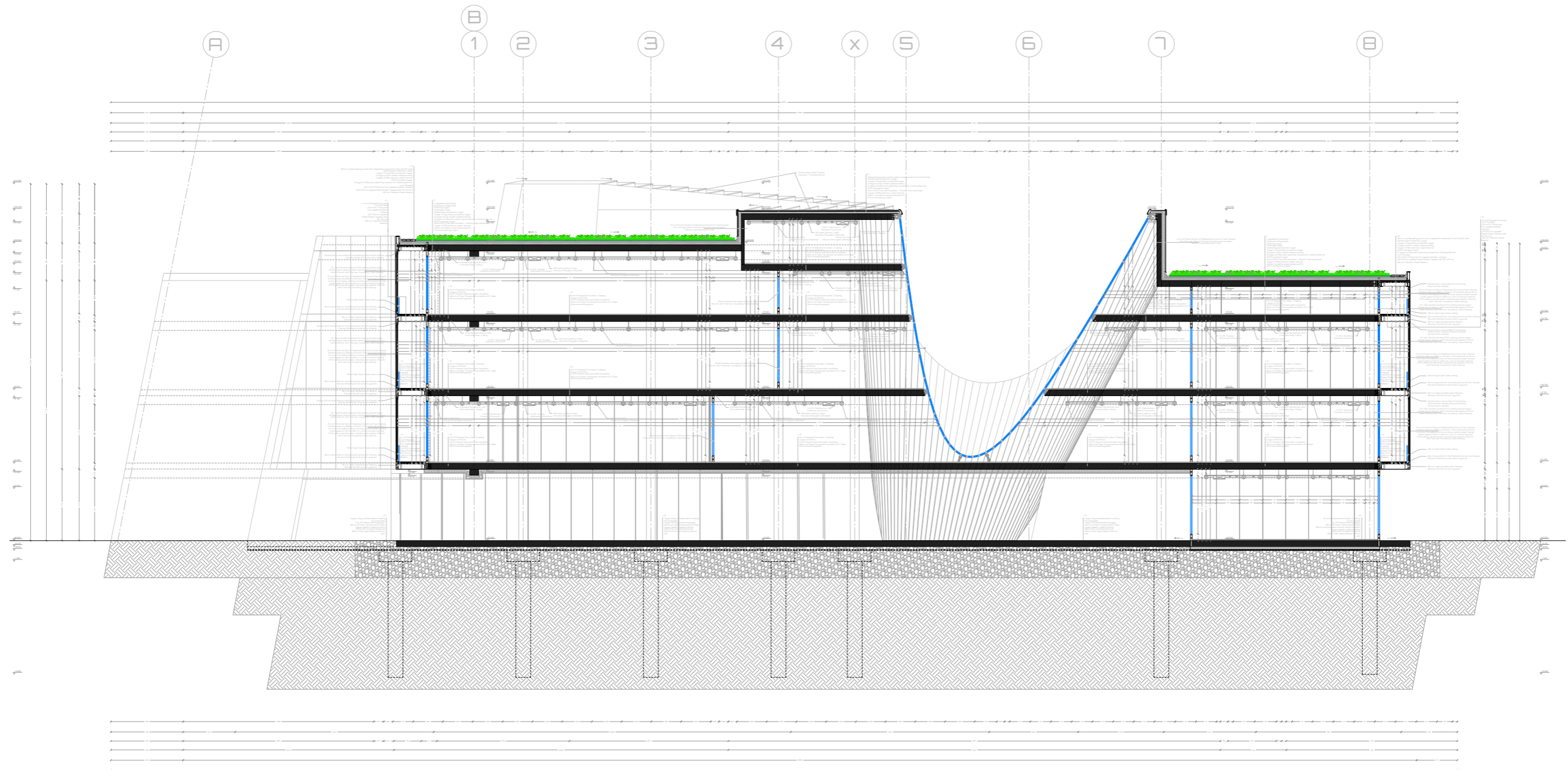

ARCHITECTURAL DRAWINGS

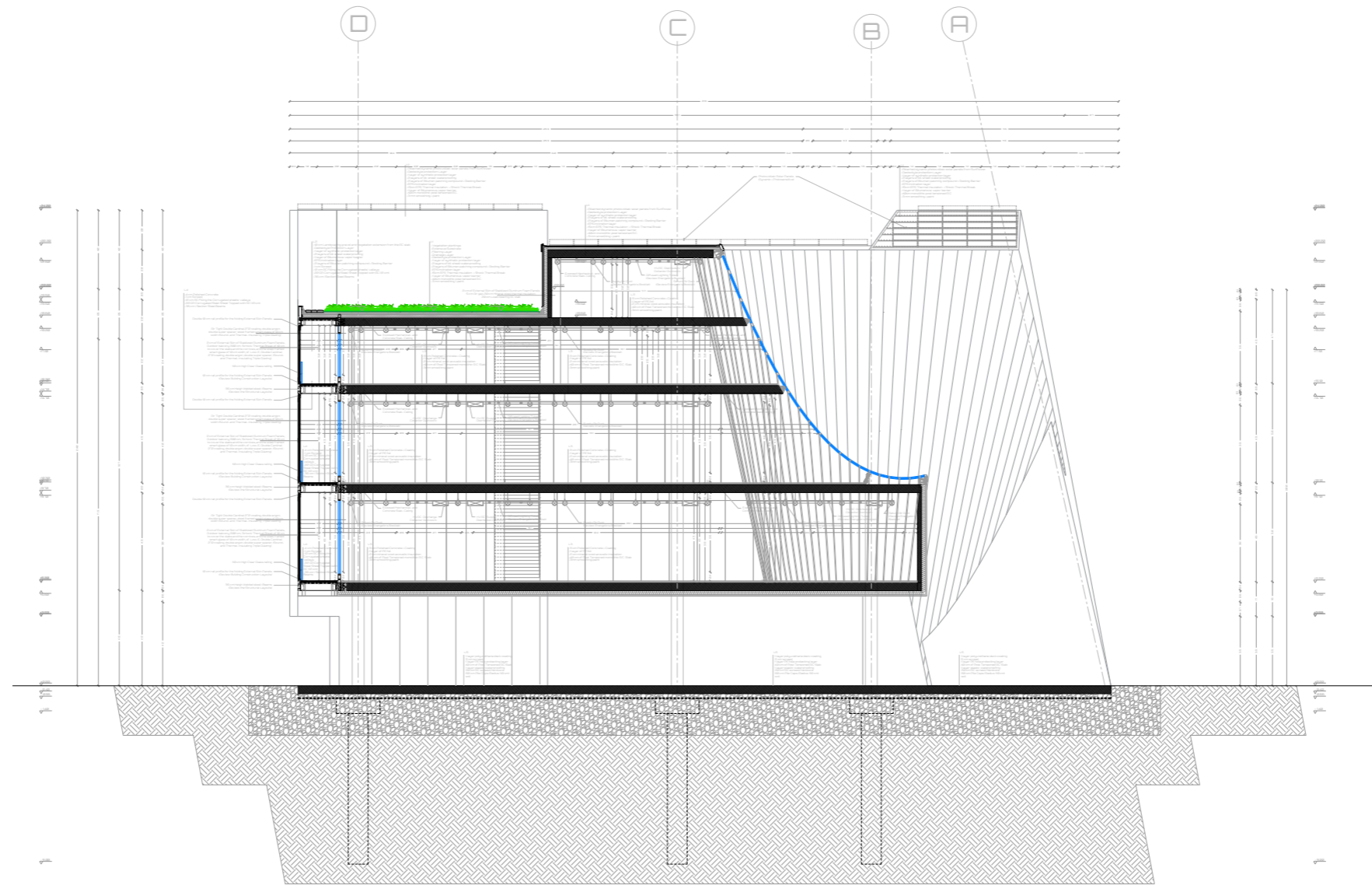

1:20 SECTION

- L2
- 10 cm Landscaping gravel and vegetation extension from the RC slab
 - Geotextyle Protection Layer
 - 1 layer of synthetic protection layer
 - 2 layers of bit. sheet waterproofing
 - 1 layer of Bitumenous vapor barrier
 - EPS inclination layer
 - 2 layers of Bitumen patching compound + Rooting Barrier
 - 1 cm Screed
 - 12 cm RC Filling the Corrugated sheets' valleys
 - 22 GA Corrugated Steel Sheet Topped with RC (12 cm)
 - 36 cm I Section Steel Beams

- L4
- 4 cm Polished Concrete
 - 1 cm Screed
 - 12 cm RC Filling the Corrugated sheets' valleys
 - 22 GA Corrugated Steel Sheet Topped with RC (12 cm)
 - 36 cm I Section Steel Beams

- L1
- Vegetation plantings
 - Extensive Substrate
 - Filtering Layer
 - Drainage Layer
 - Geotextyle protection Layer
 - 1 layer of synthetic protection layer
 - 2 layers of bit. sheet waterproofing
 - 2 layers of Bitumen patching compound + Rooting Barrier
 - EPS inclination layer
 - 15cm Thermal Insulation + Shock Thermal Break
 - 1 layer of Bitumenous vapor barrier
 - 40cm monolithic post tensioned R.C.
 - 3 mm smoothing + paint

+24.00

+22.20

+21.60

+19.50

+15.10

+14.70

8.7%

Double 10 cm rail profile for the folding External Skin Panels (Review Building Construction Details)

Air Tight Double Cardinal 272 coating, double argon, double super spacer, steel framed smart glass of 10 cm width (Sound- and Thermal- Insulating Triple Glazing)

2 cm of External Skin of Stabilized Aluminum Foam Panels, Outdoor balcony 200 cm, Schock Thermal Break of 10 cm to cover the slabs and the cornices, and the steel framed smart glass of 10 cm width, of Low-E, Double Cardinal 272 coating, double argon, double super spacer, (Sound- and Thermal- Insulating Triple Glazing)

110 cm high Clear Glass railing

10 cm rail profile for the folding External Skin Panels (Review Building Construction Layouts)

36 cm Heigh Welded steel I Beams (Review the Structural Layouts)

Double 10 cm rail profile for the folding External Skin Panels

Exposed Mechanical- and Concrete Slab- Ceiling

HVAC Discharge Collector Ductwork

Return Air Duct (Review Energetic's Booklet)

- L3
- 9 cm Polished Concrete + Coating
 - 1 layer of PE foil
 - 2 cm mineral wool acoustic insulation
 - 40 cm of Post Tensioned monolithic R.C. Slab
 - 3mm smoothing+paint

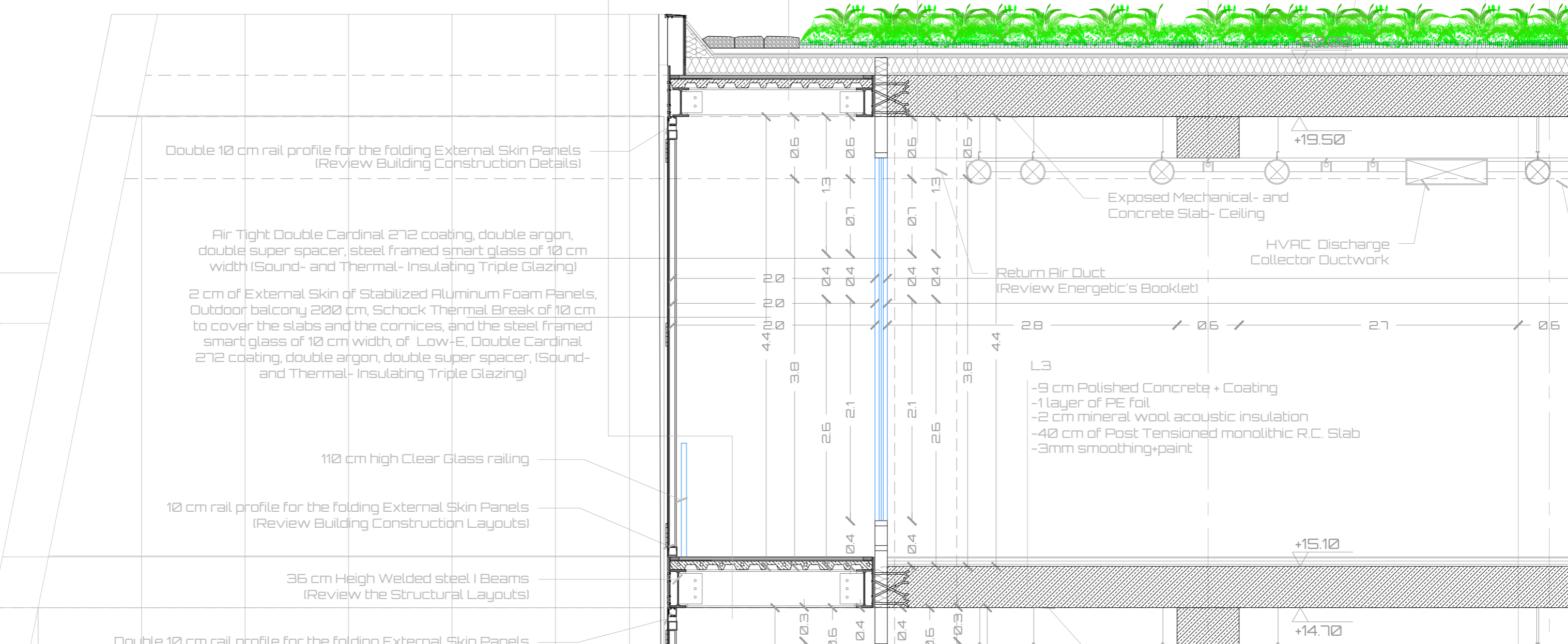

1:20 SECTION

Air Tight Double Cardinal 272 coating, double argon, double super spacer, steel framed smart glass of 10 cm width (Sound- and Thermal- Insulating Triple Glazing)

2 cm of External Skin of Stabilized Aluminum Foam Panels, Outdoor balcony 200 cm, Schock Thermal Break of 10 cm to cover the slabs and the cornices, and the steel framed smart glass of 10 cm width, of Low-E, Double Cardinal 272 coating, double argon, double super spacer, (Sound- and Thermal- Insulating Triple Glazing)

110 cm high Clear Glass railing

10 cm rail profile for the folding External Skin Panels (Review Building Construction Layouts)

36 cm High Welded steel I Beams (Review the Structural Layouts)

Double 10 cm rail profile for the folding External Skin Panels (Review Building Construction Details)

Air Tight Double Cardinal 272 coating, double argon, double super spacer, steel framed smart glass of 10 cm width (Sound- and Thermal- Insulating Triple Glazing)

2 cm of External Skin of Stabilized Aluminum Foam Panels, Outdoor balcony 200 cm, Schock Thermal Break of 10 cm to cover the slabs and the cornices, and the steel framed smart glass of 10 cm width, of Low-E, Double Cardinal 272 coating, double argon, double super spacer, (Sound- and Thermal- Insulating Triple Glazing)

110 cm high Clear Glass railing

10 cm rail profile for the folding External Skin Panels (Review Building Construction Layouts)

36 cm High Welded steel I Beams (Review the Structural Layouts)

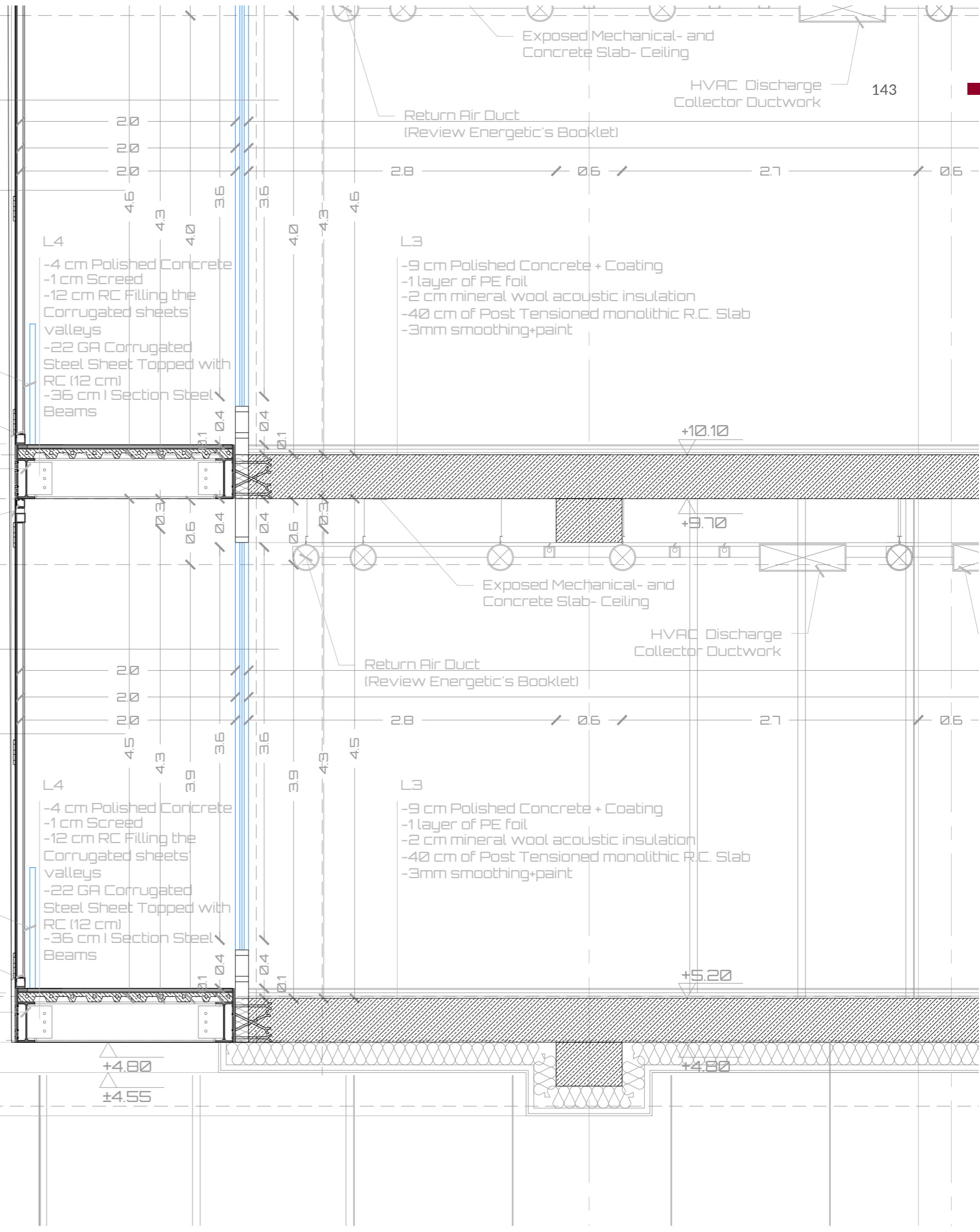

Exposed Mechanical- and Concrete Slab- Ceiling

HVAC Discharge Collector Ductwork

Return Air Duct (Review Energetic's Booklet)

Exposed Mechanical- and Concrete Slab- Ceiling

HVAC Discharge Collector Ductwork

Return Air Duct (Review Energetic's Booklet)

1:20 SECTION

L0

- Attached dynamic photovoltaic solar panels from SunPower
- Geotextyle protection Layer
- 1 layer of synthetic protection layer
- 2 layers of bit. sheet waterproofing
- 2 layers of Bitumen patching compound + Rooting Barrier
- EPS inclination layer
- 15cm EPS Thermal Insulation + Shock Thermal Break
- 1 layer of Bitumenous vapor barrier
- 40cm monolithic post tensioned R.C.
- 3 mm smoothing + paint

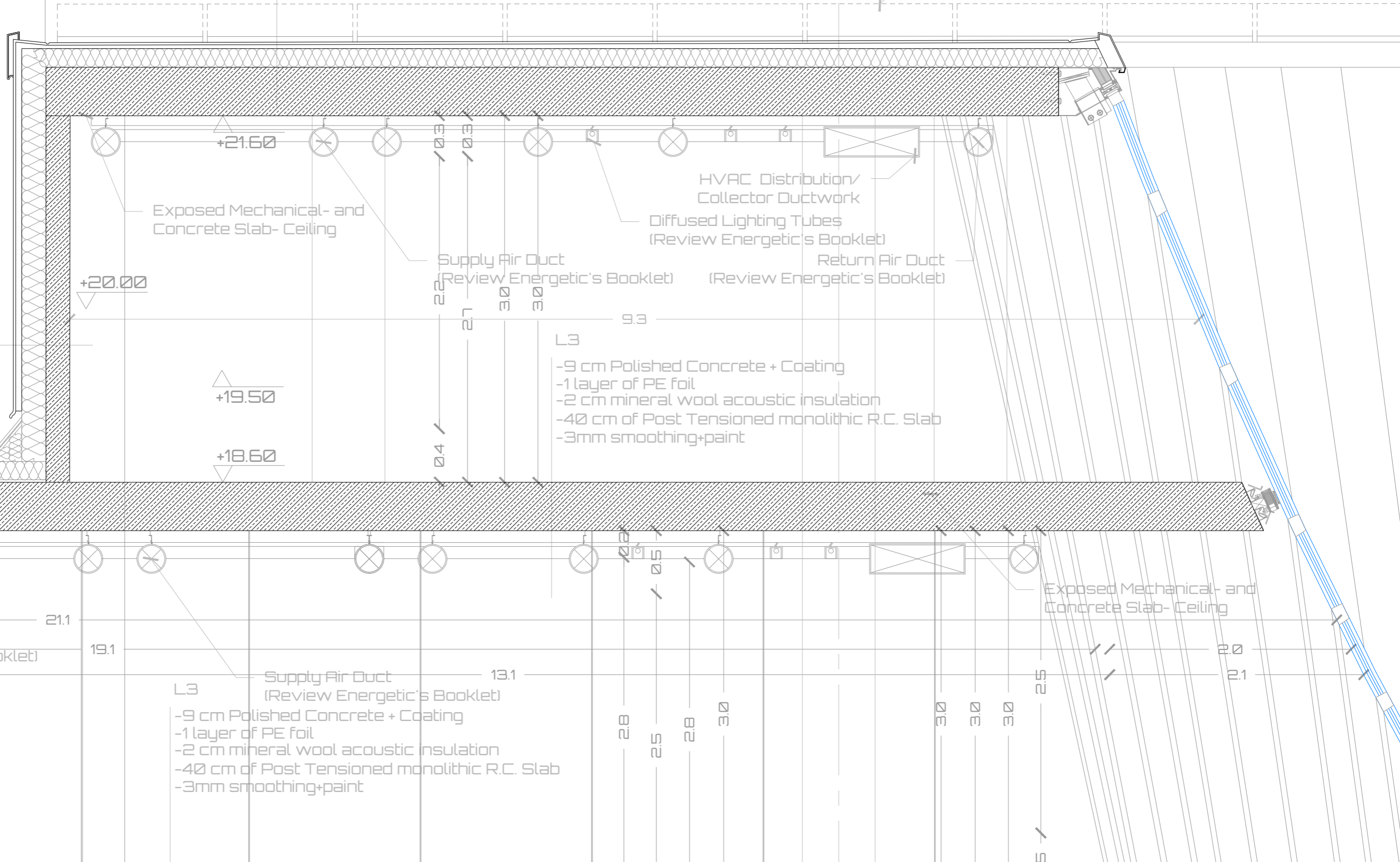

Exposed Mechanical- and Concrete Slab- Ceiling

HVAC Distribution/ Collector Ductwork

Diffused Lighting Tubes (Review Energetic's Booklet)

Return Air Duct (Review Energetic's Booklet)

Supply Air Duct (Review Energetic's Booklet)

+20.00

+19.50

+18.60

L3

- 9 cm Polished Concrete + Coating
- 1 layer of PE foil
- 2 cm mineral wool acoustic insulation
- 40 cm of Post Tensioned monolithic R.C. Slab
- 3mm smoothing+paint

Exposed Mechanical- and Concrete Slab- Ceiling

21.1

19.1

13.1

L3

- 9 cm Polished Concrete + Coating
- 1 layer of PE foil
- 2 cm mineral wool acoustic insulation
- 40 cm of Post Tensioned monolithic R.C. Slab
- 3mm smoothing+paint

2.0

2.5

2.0

3.0

3.0

3.0

3.0

2.5

2.0

2.1

5

rier

<

ed Aluminum Foam Panels
Wool thermal insulation,
ring RC wall

Diffused Lighting Tubes
(Review Energetic's Booklet)

1:20 SECTION

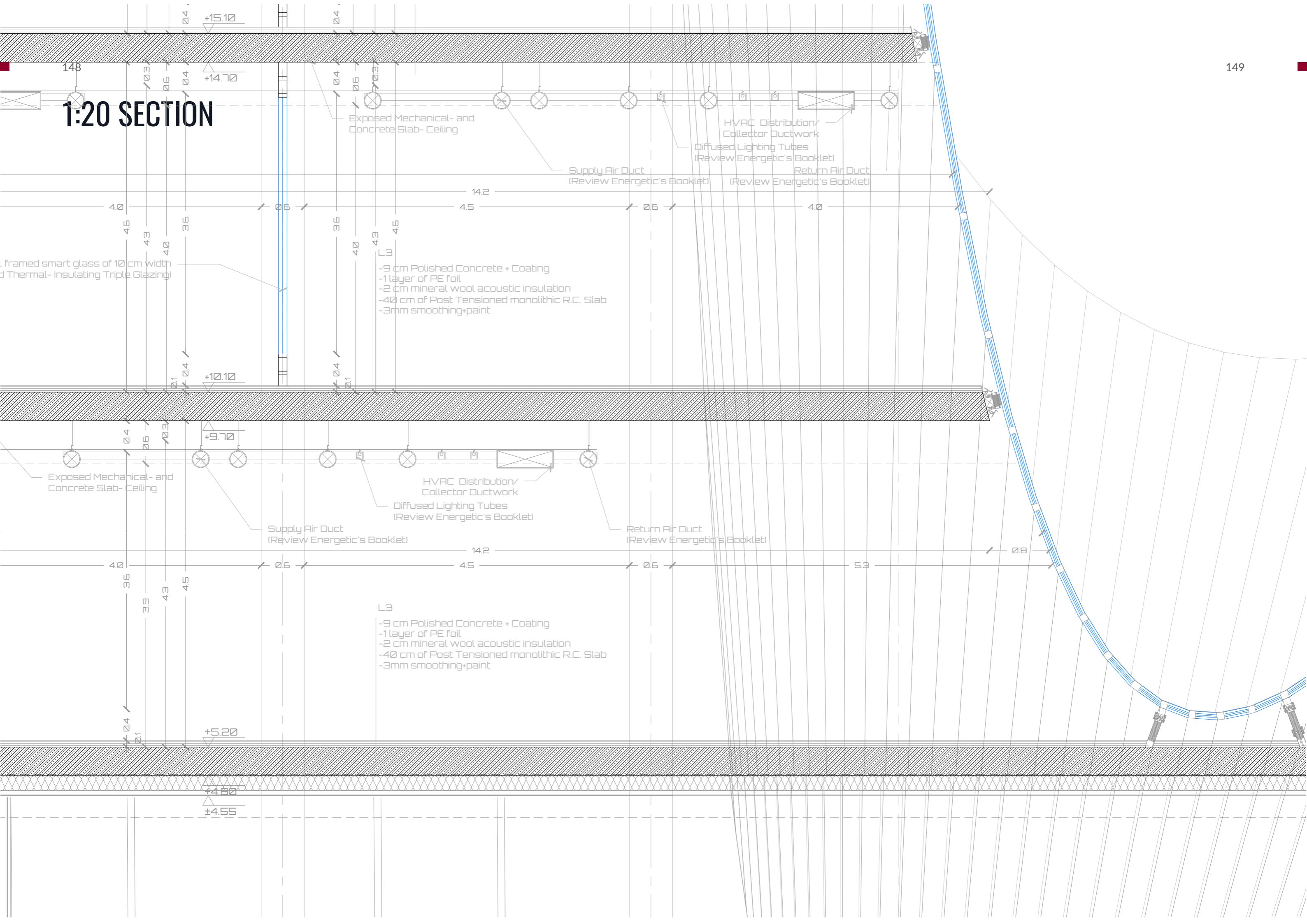

- Framed smart glass of 10 cm width
 (Thermal- Insulating Triple Glazing)

Exposed Mechanical- and
 Concrete Slab- Ceiling

HVAC Distribution/
 Collector Ductwork
 Diffused Lighting Tubes
 (Review Energetic's Booklet)

Supply Air Duct
 (Review Energetic's Booklet)

Return Air Duct
 (Review Energetic's Booklet)

-9 cm Polished Concrete + Coating
 -1 layer of PE foil
 -2 cm mineral wool acoustic insulation
 -40 cm of Post Tensioned monolithic R.C. Slab
 -3mm smoothing+paint

Exposed Mechanical- and
 Concrete Slab- Ceiling

HVAC Distribution/
 Collector Ductwork
 Diffused Lighting Tubes
 (Review Energetic's Booklet)

Supply Air Duct
 (Review Energetic's Booklet)

Return Air Duct
 (Review Energetic's Booklet)

L3
 -9 cm Polished Concrete + Coating
 -1 layer of PE foil
 -2 cm mineral wool acoustic insulation
 -40 cm of Post Tensioned monolithic R.C. Slab
 -3mm smoothing+paint

DETAILS

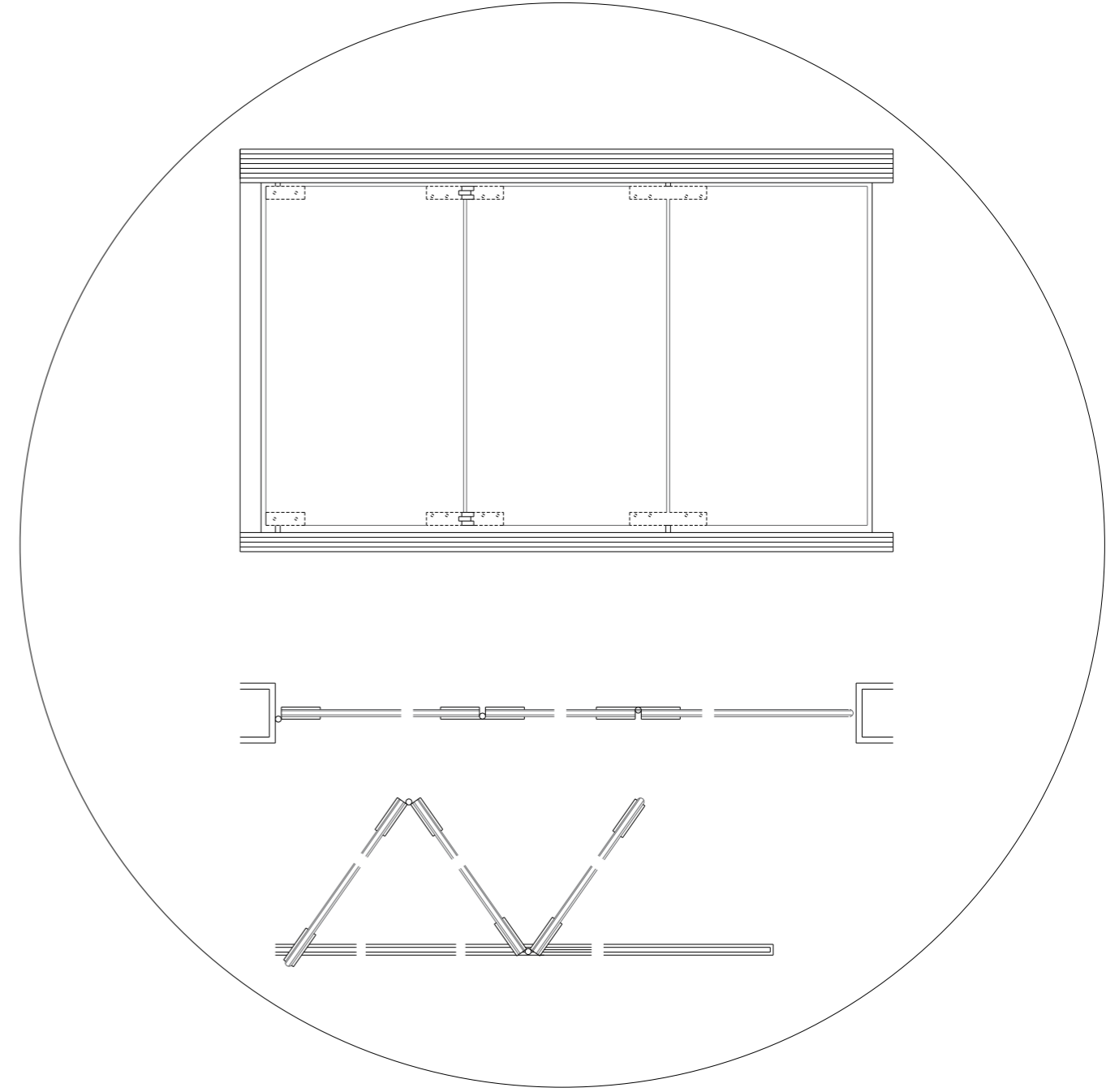
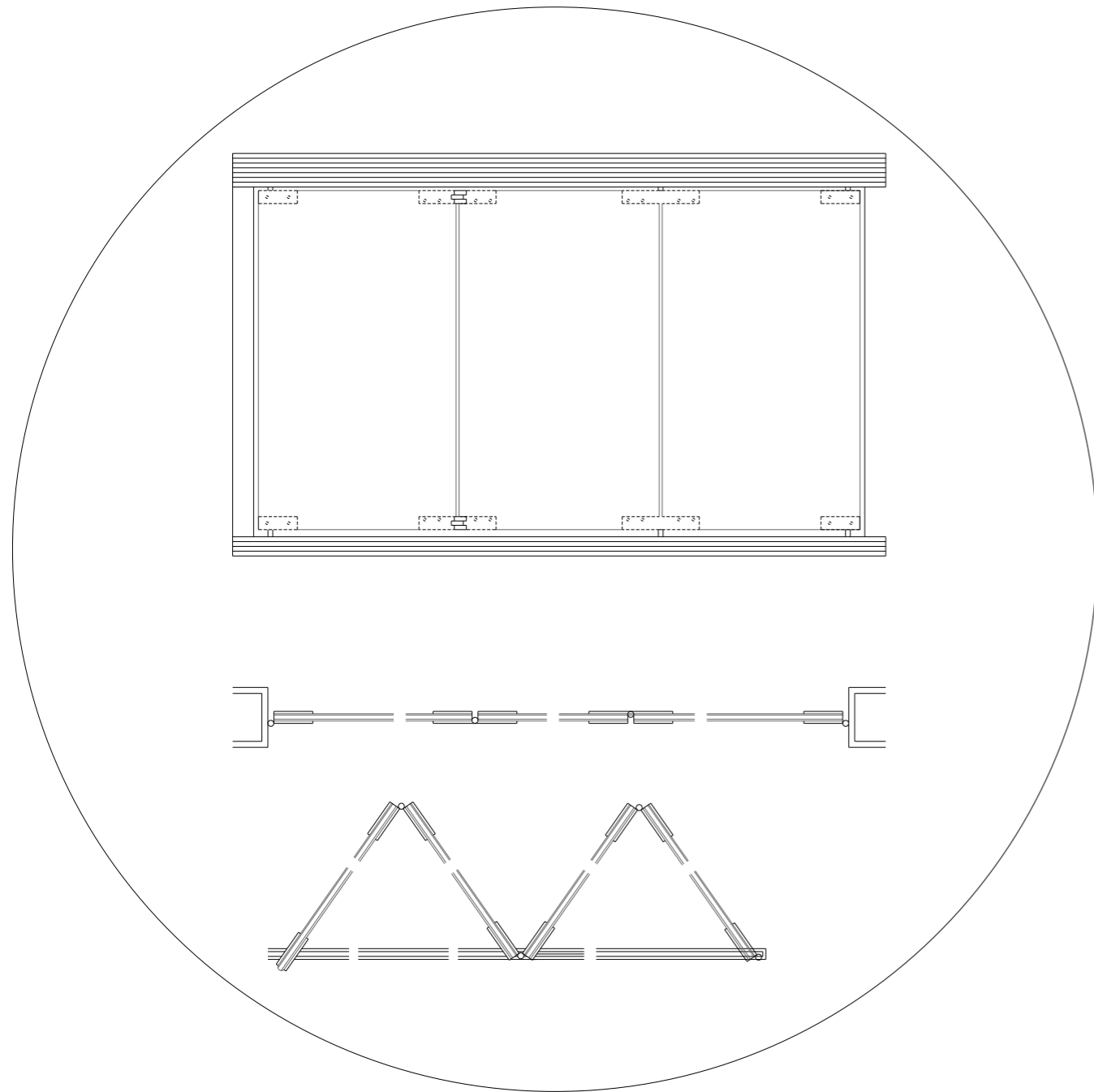

DETAILS

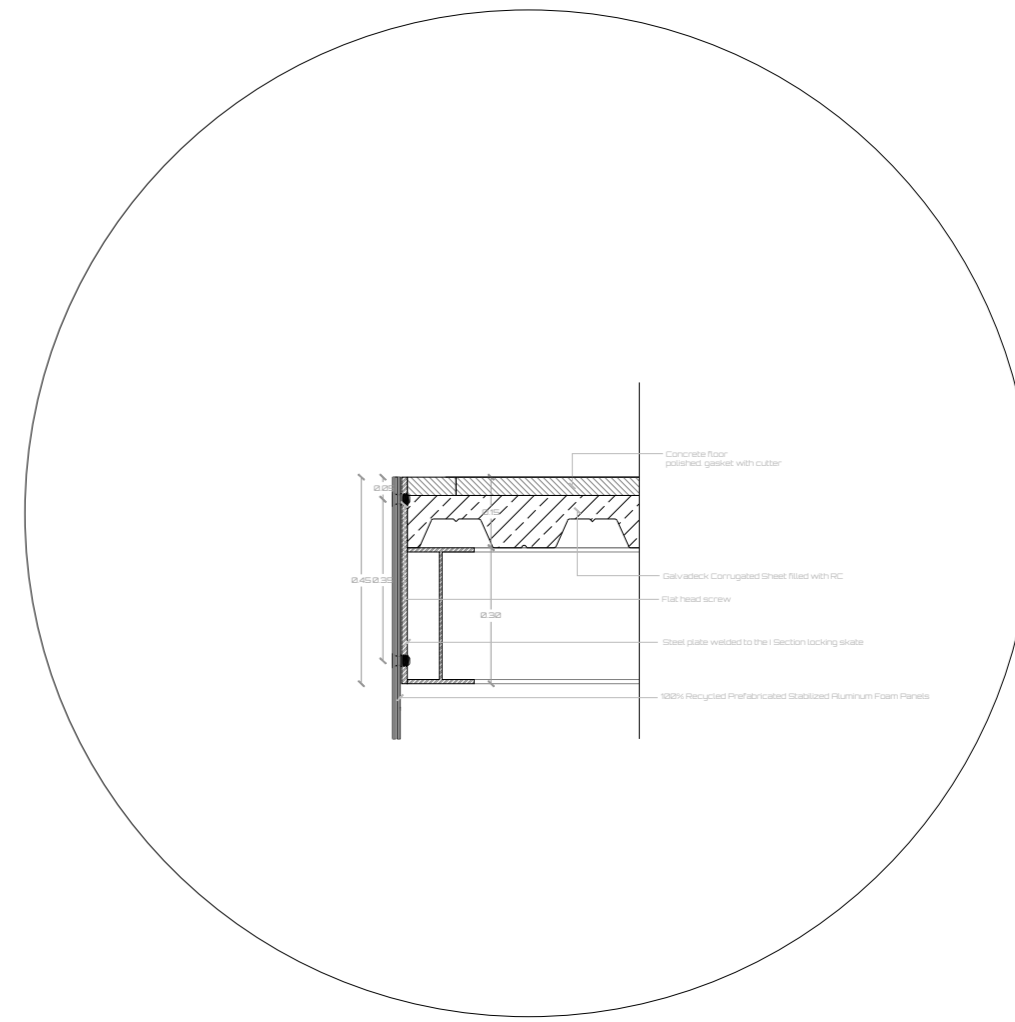
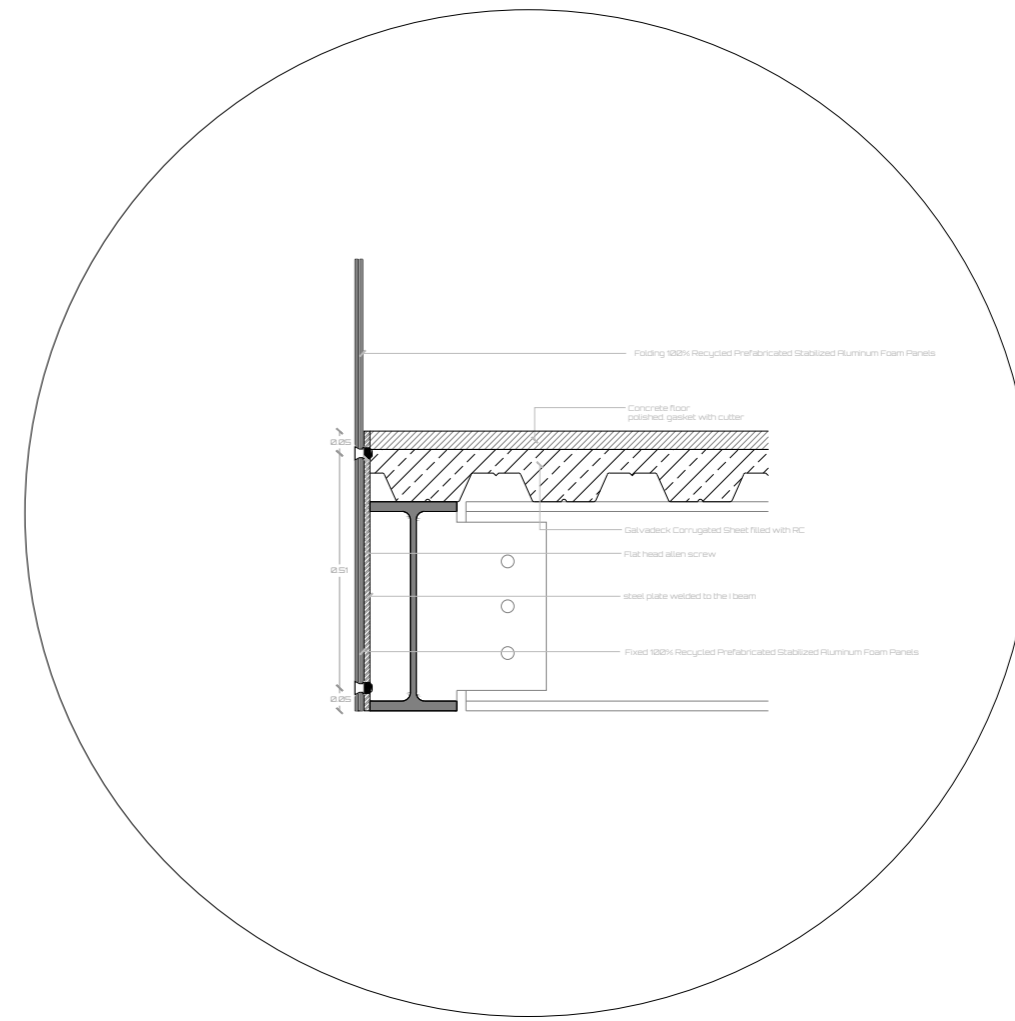
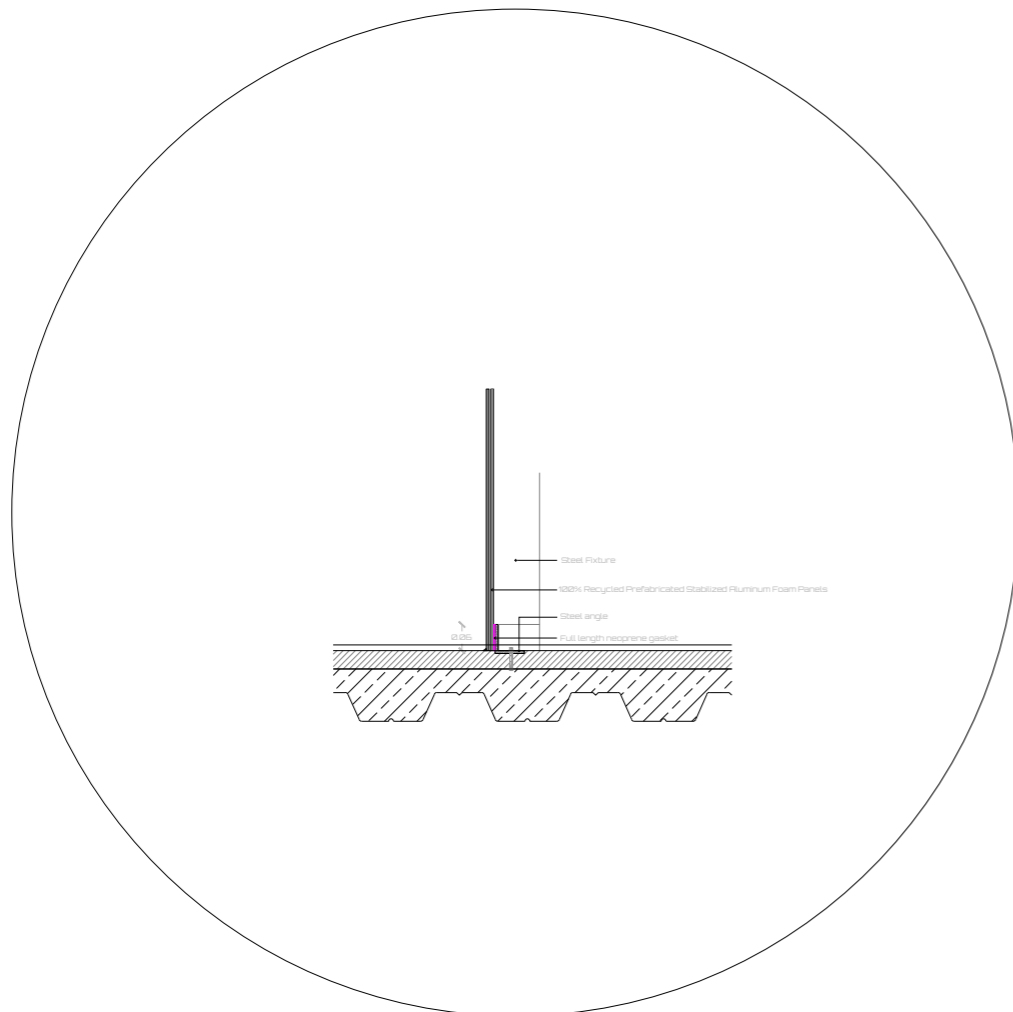
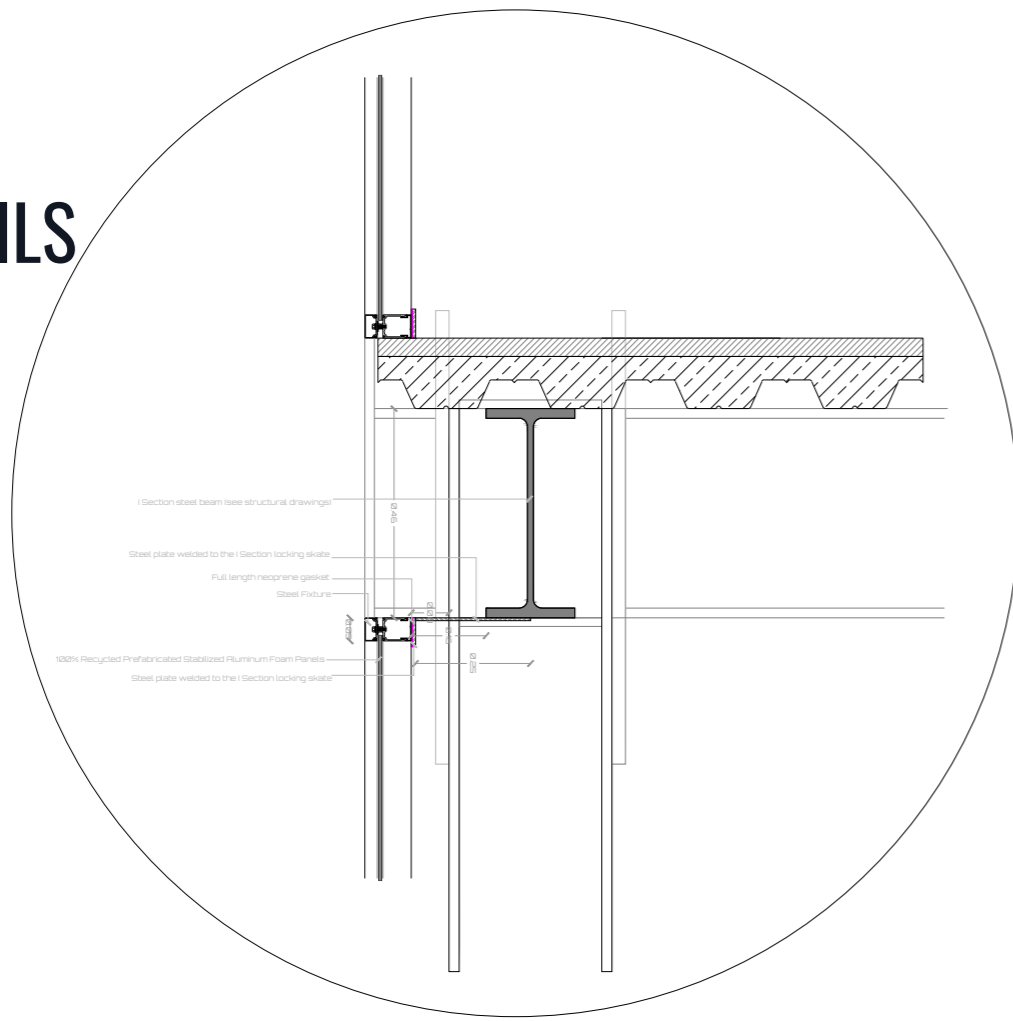

DETAILS

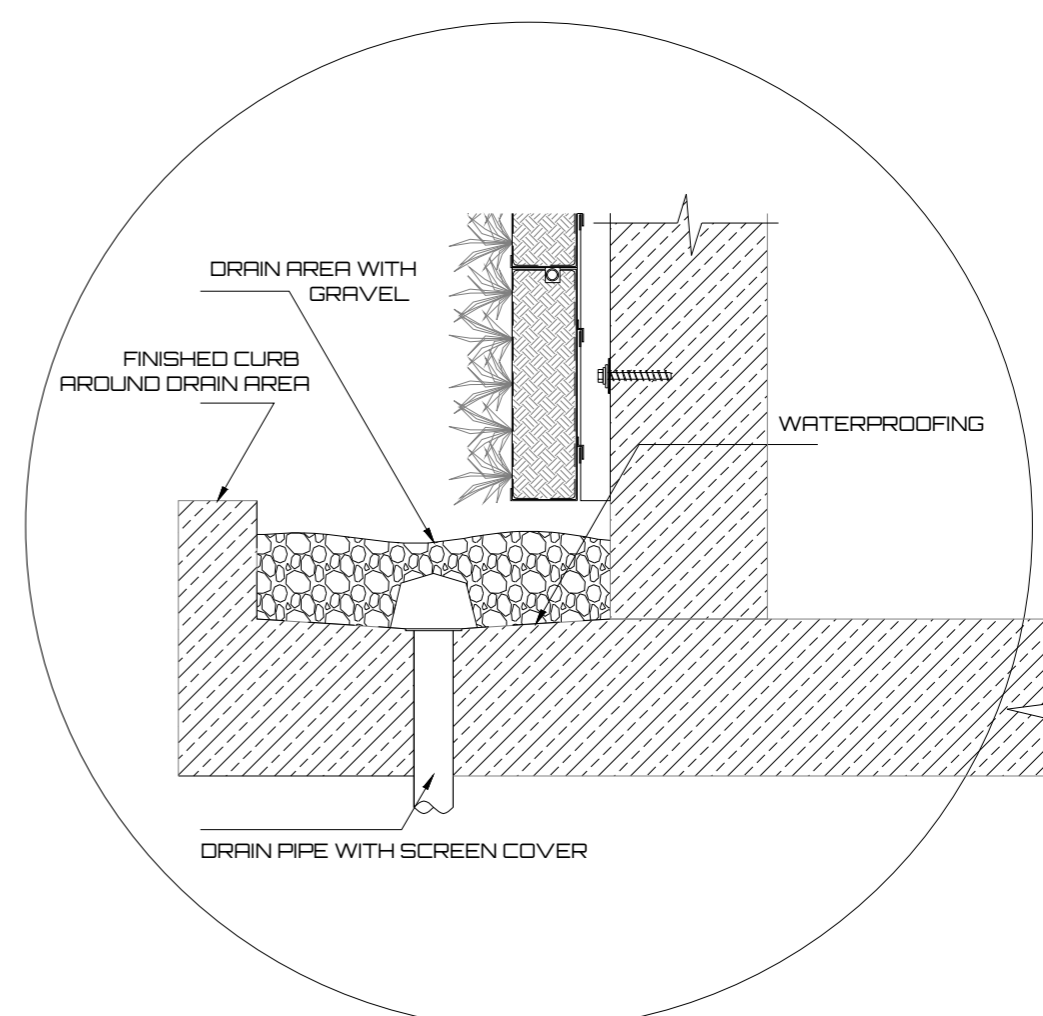
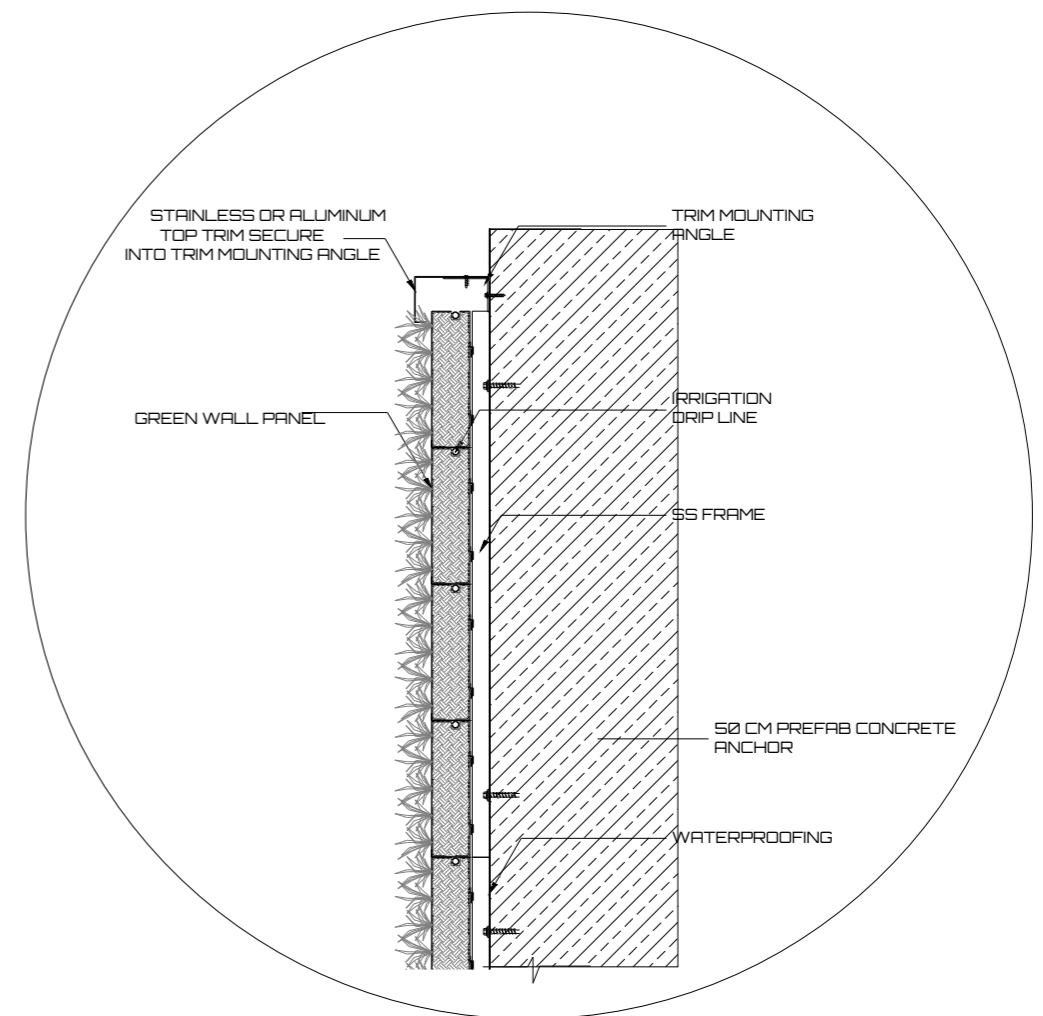
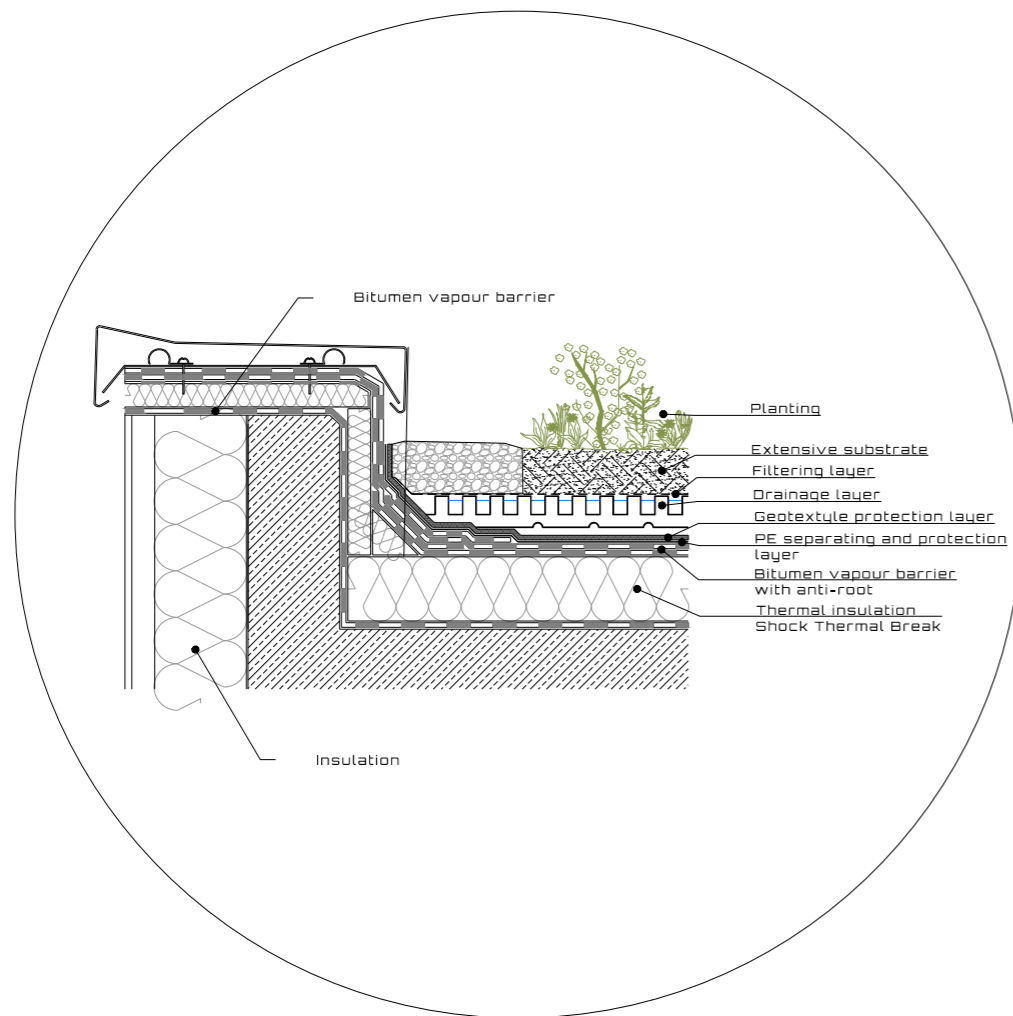
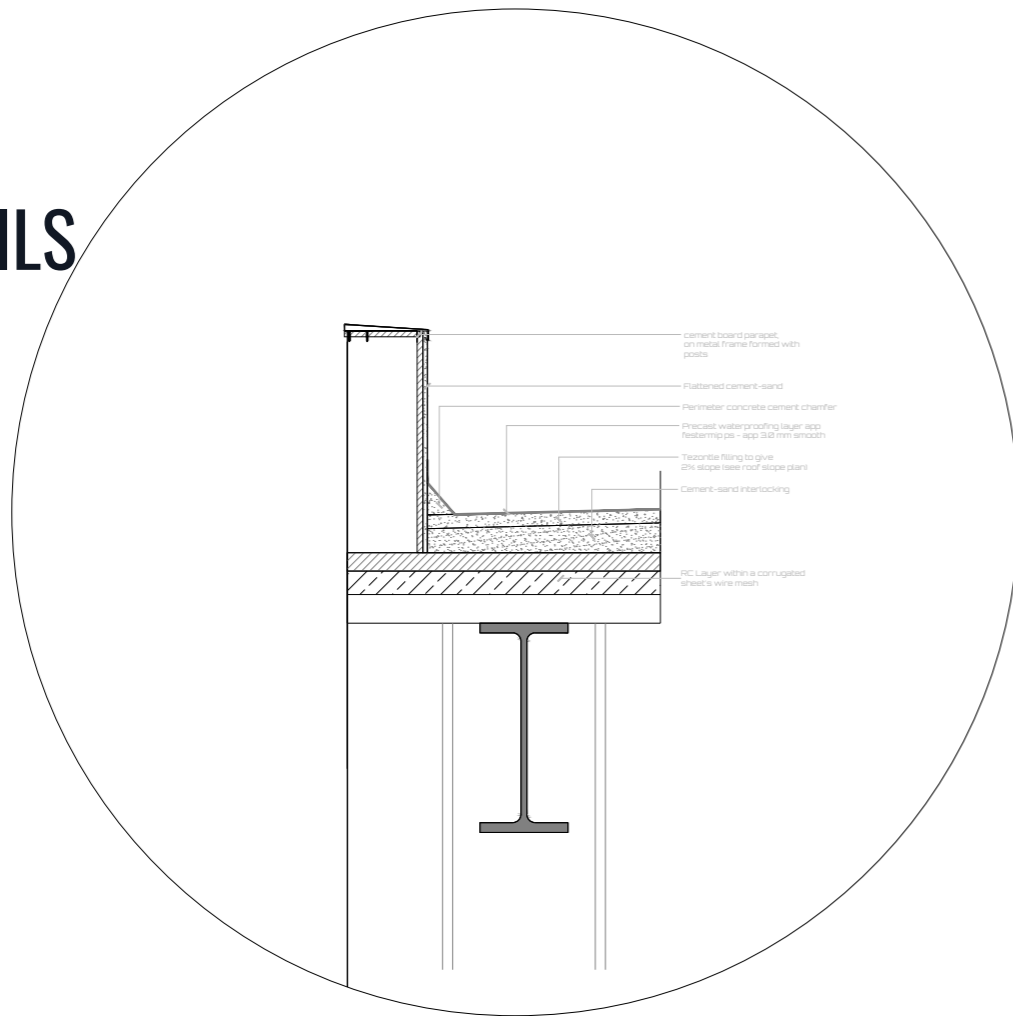

DETAILS

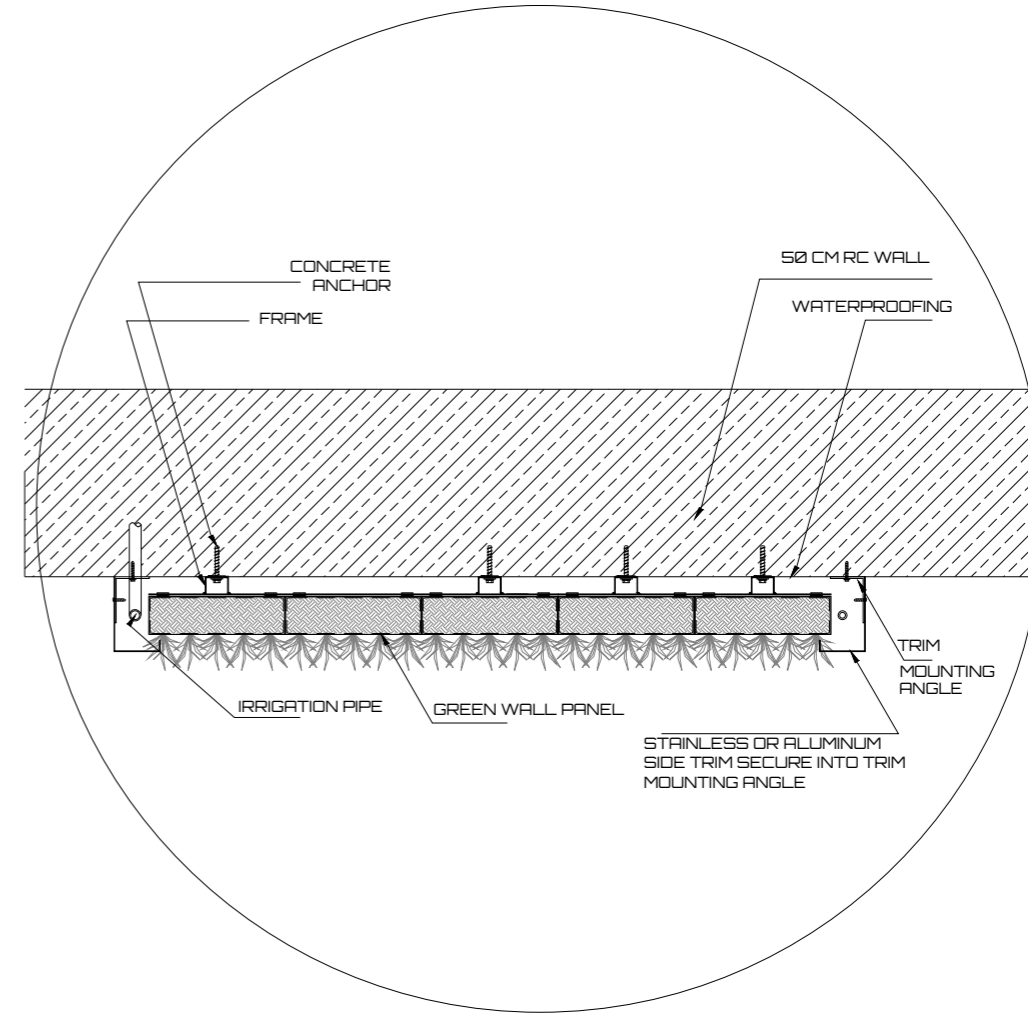
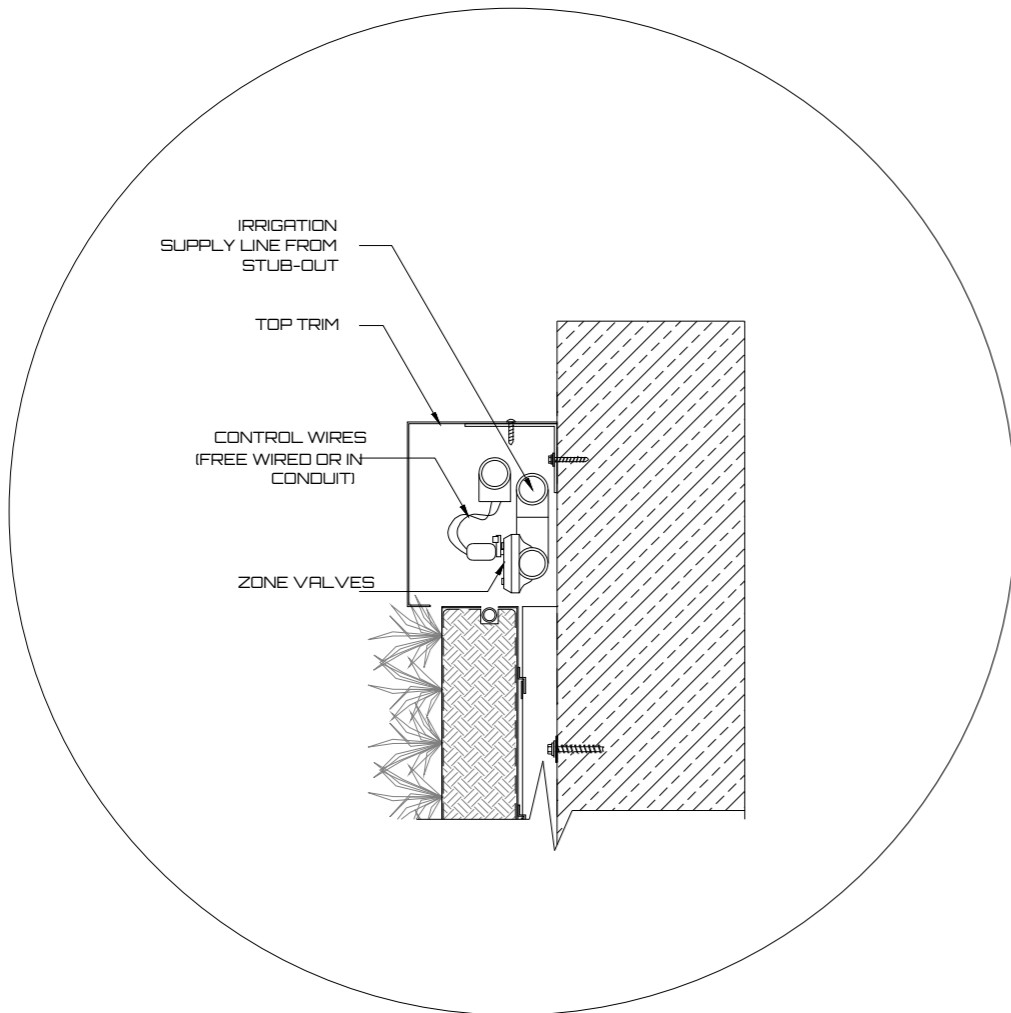
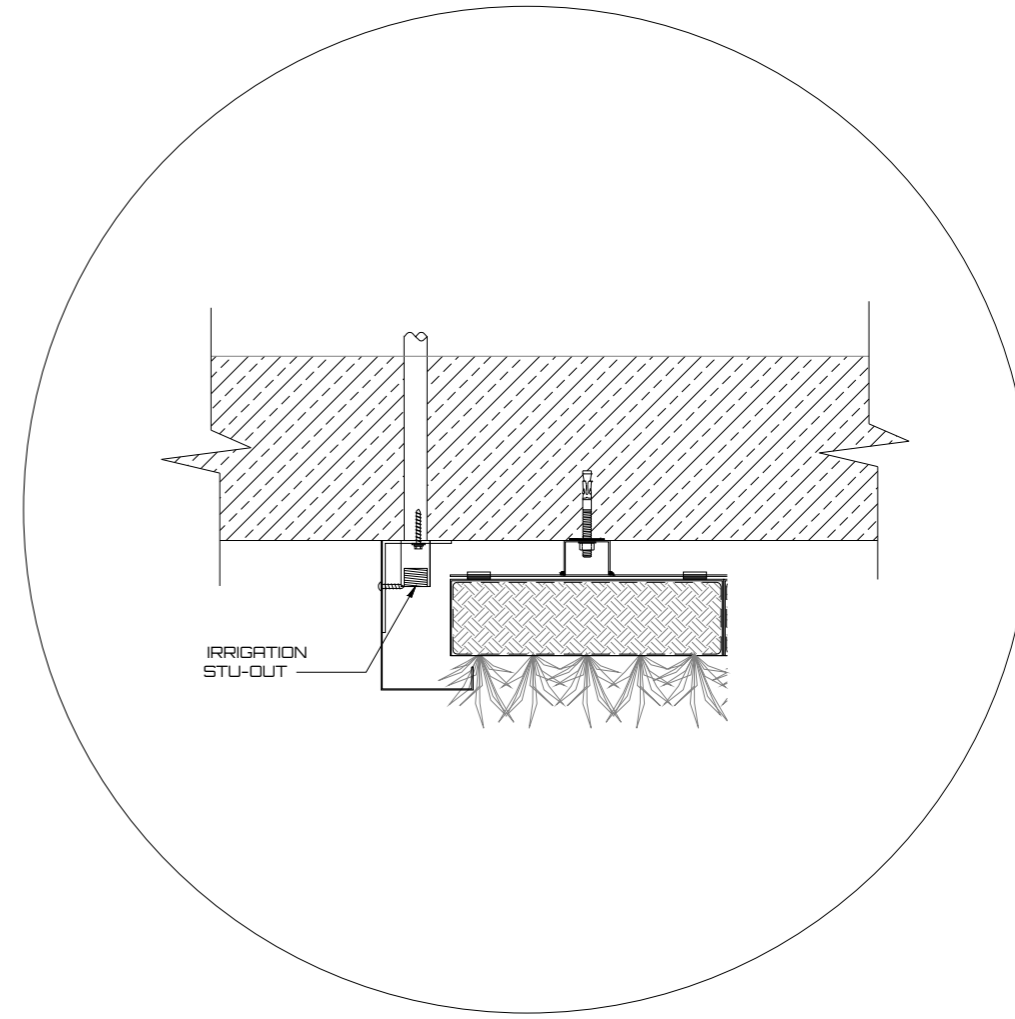
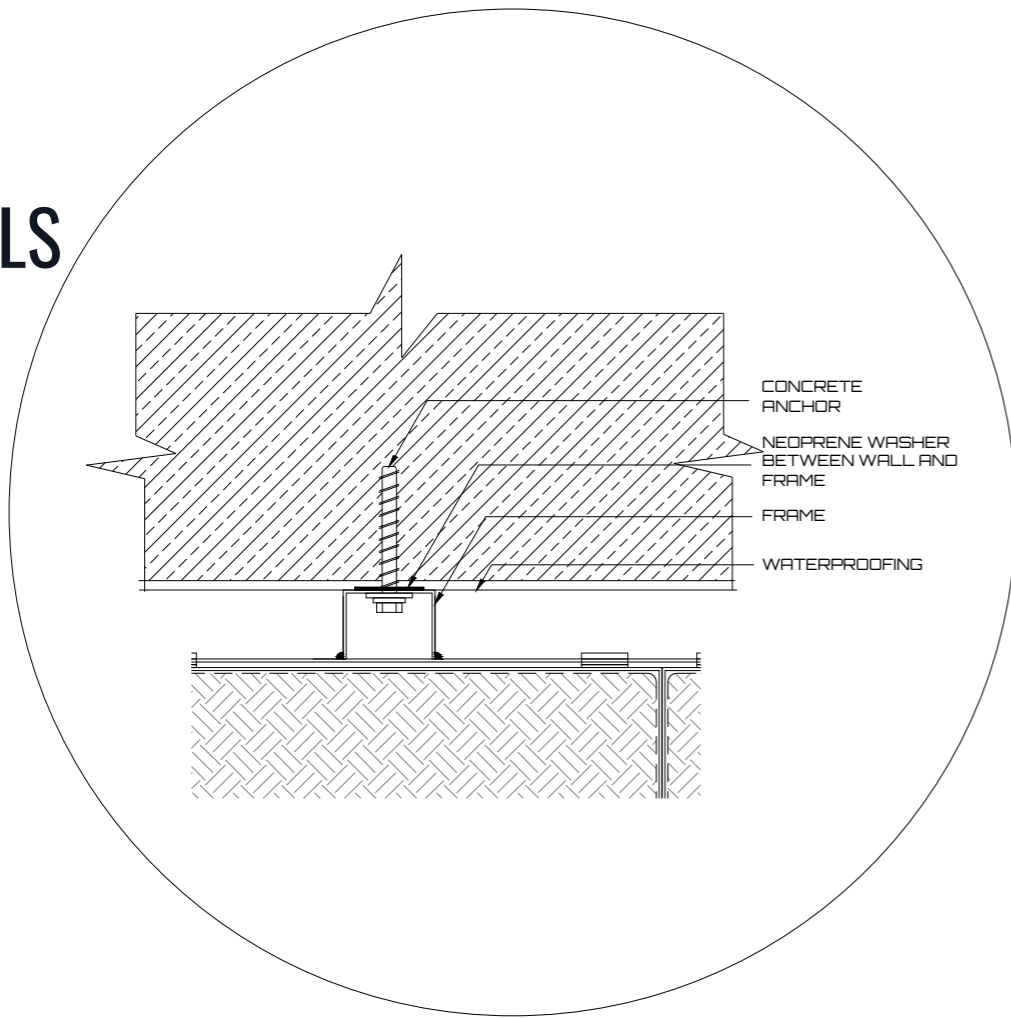

DETAILS

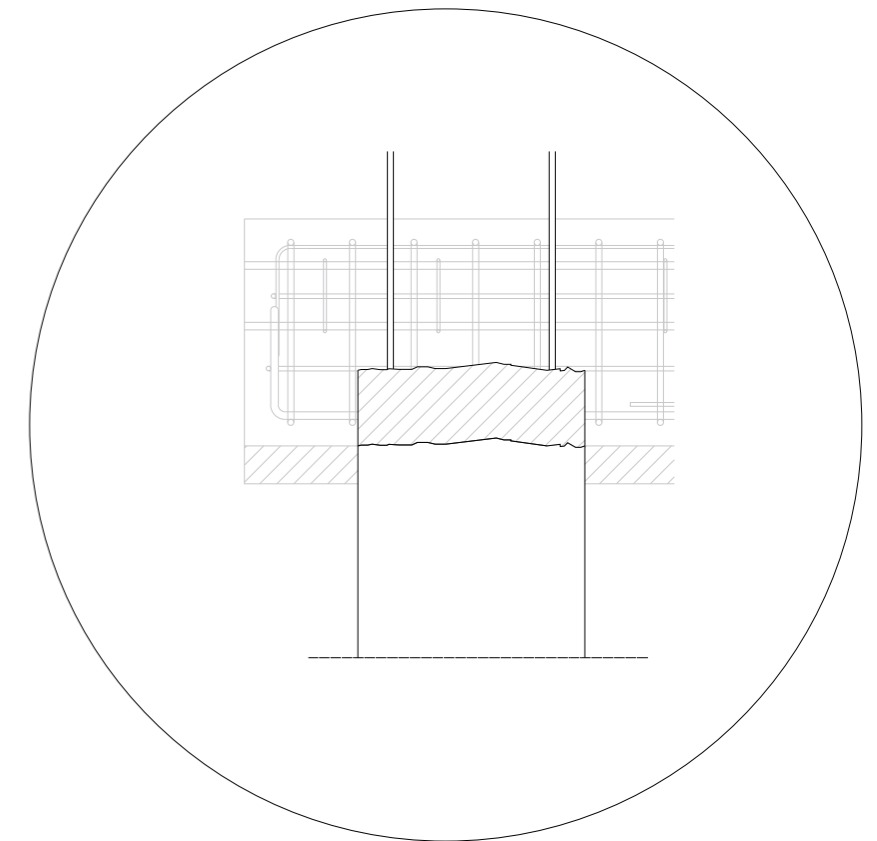
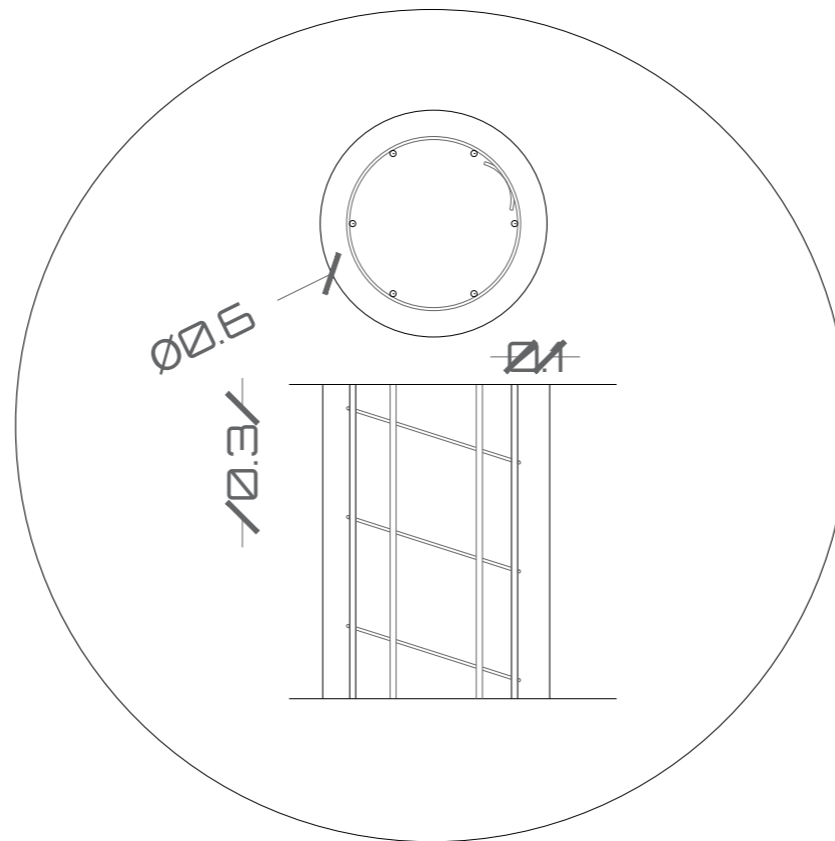
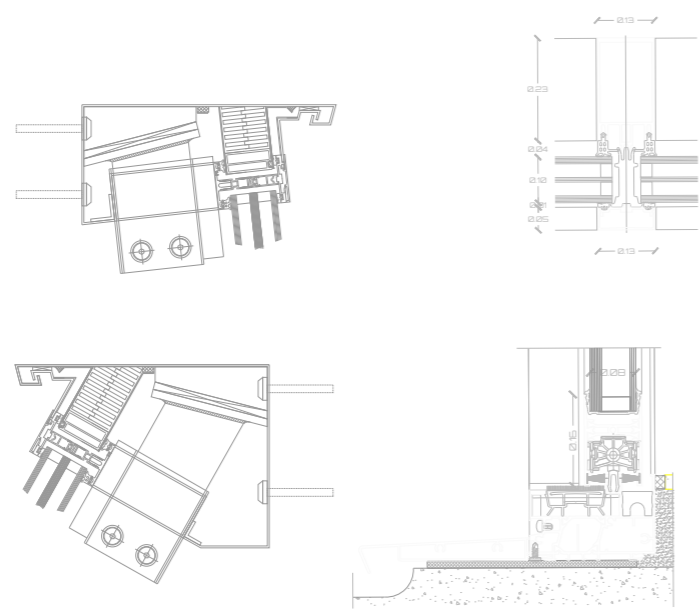
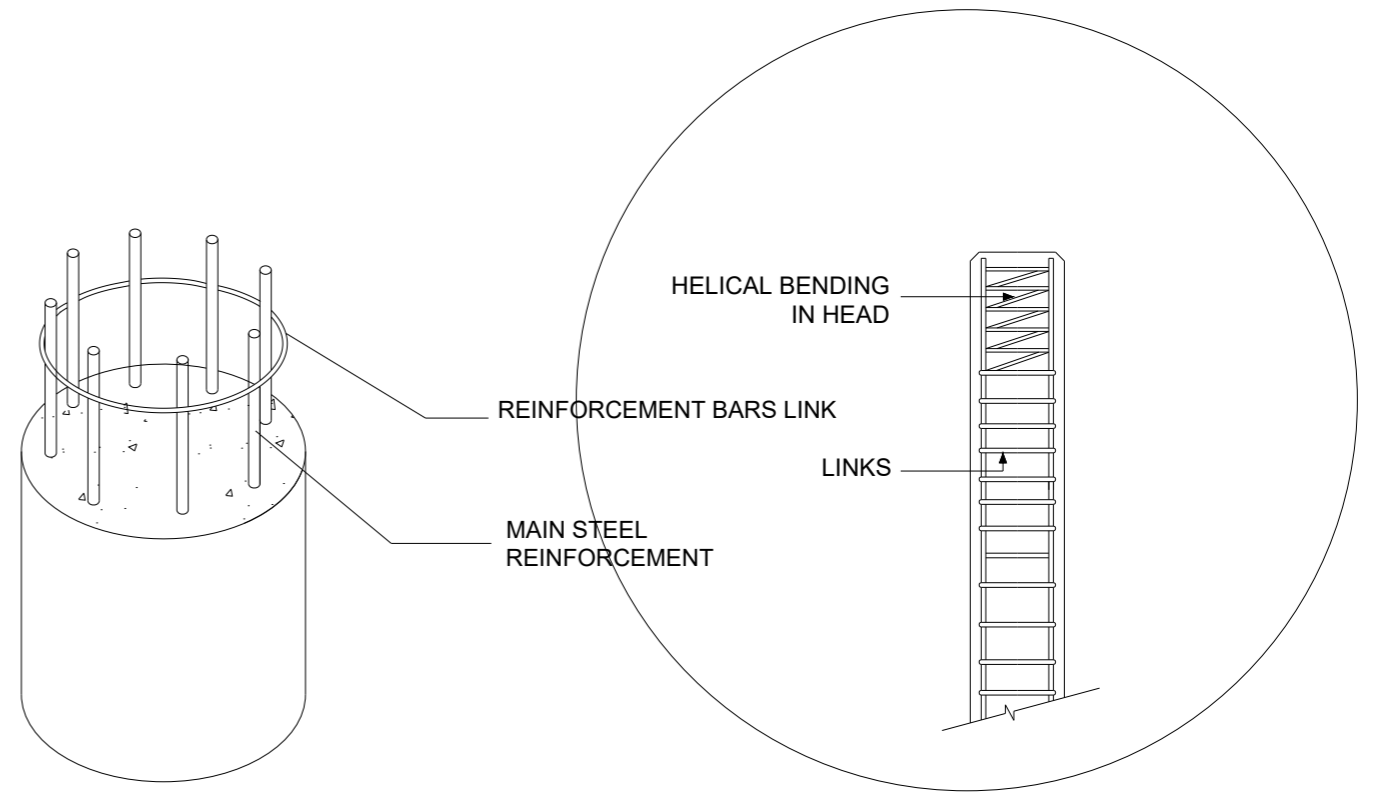
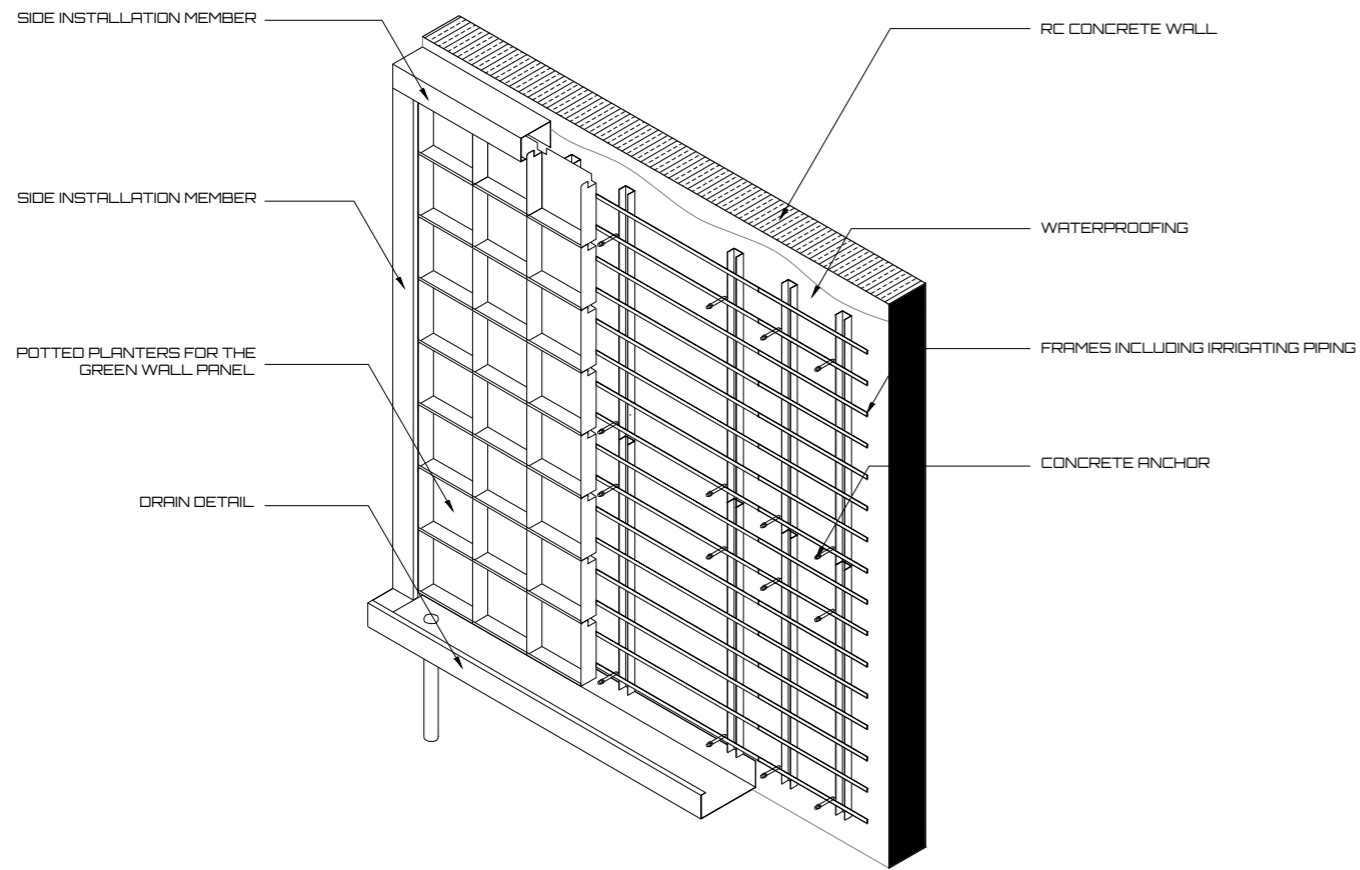

SERVICE SYSTEMS 3D MODEL

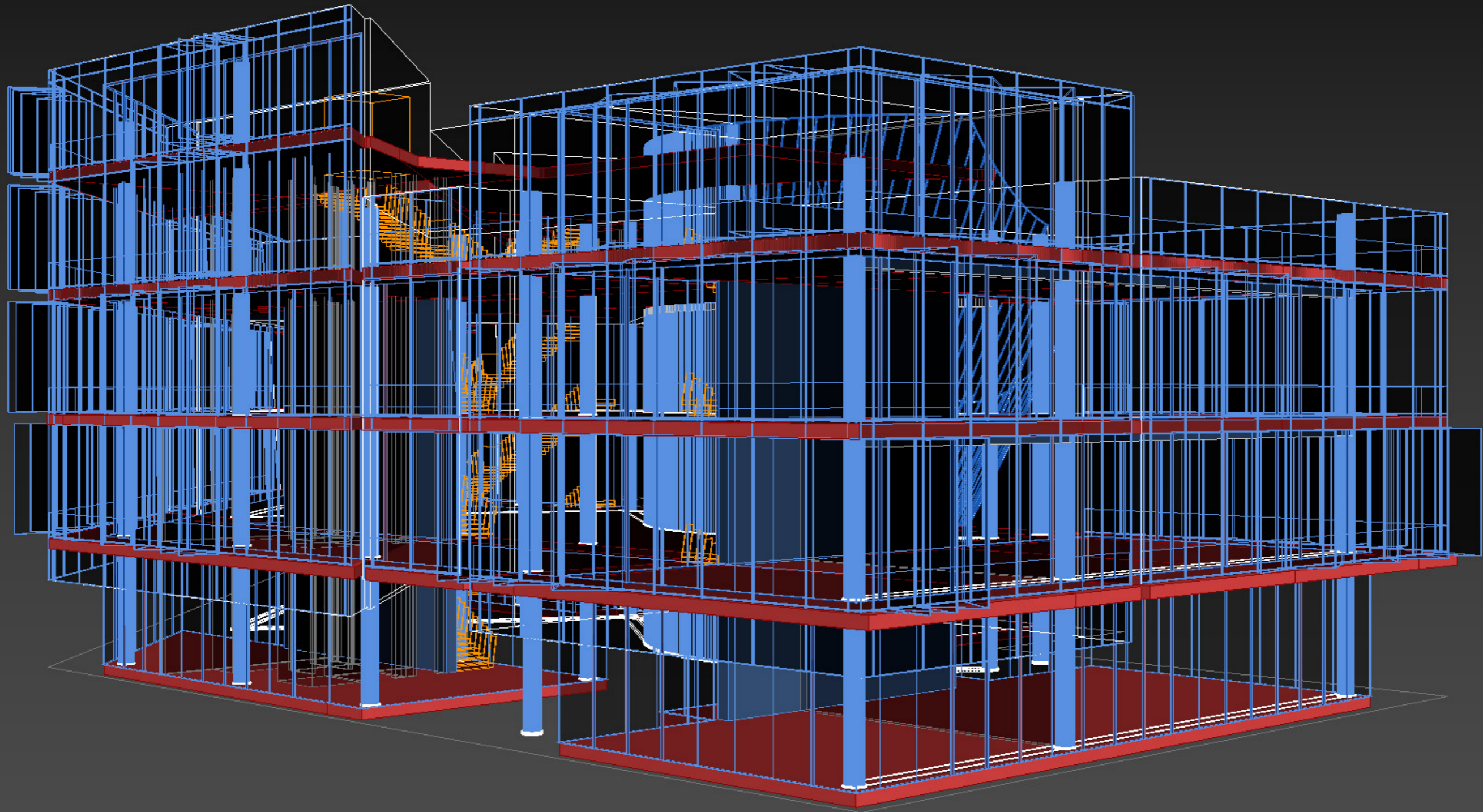

RIGHT



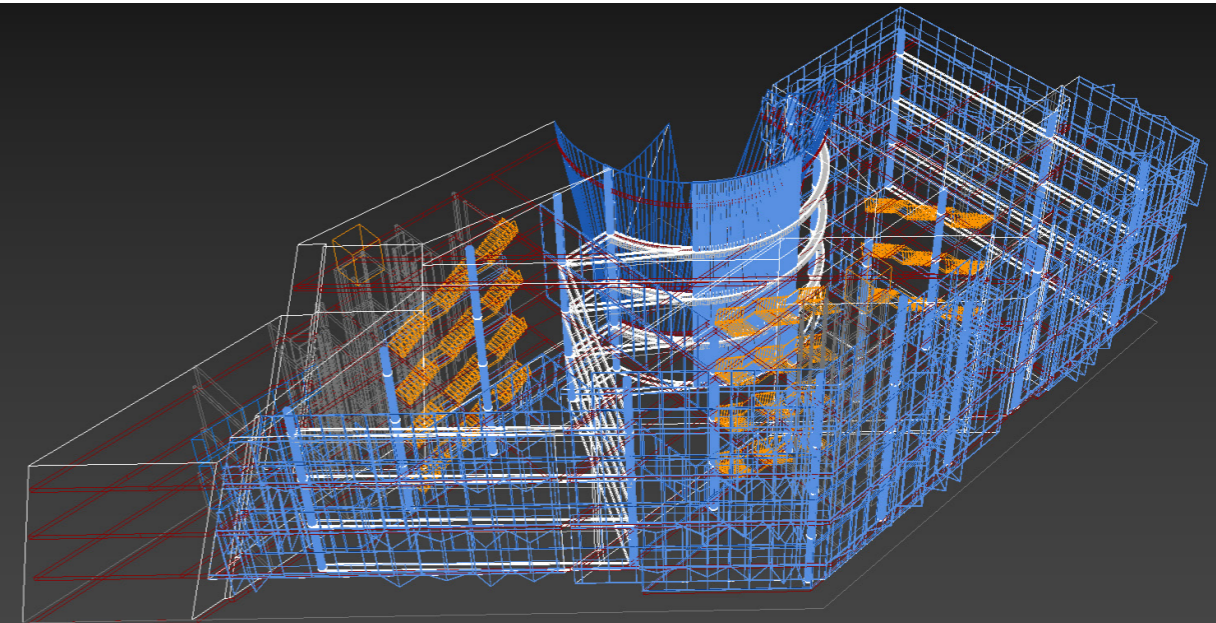
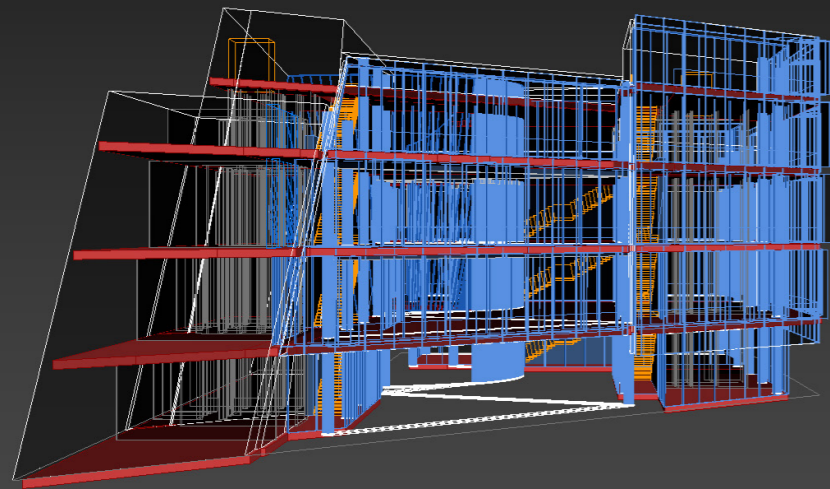
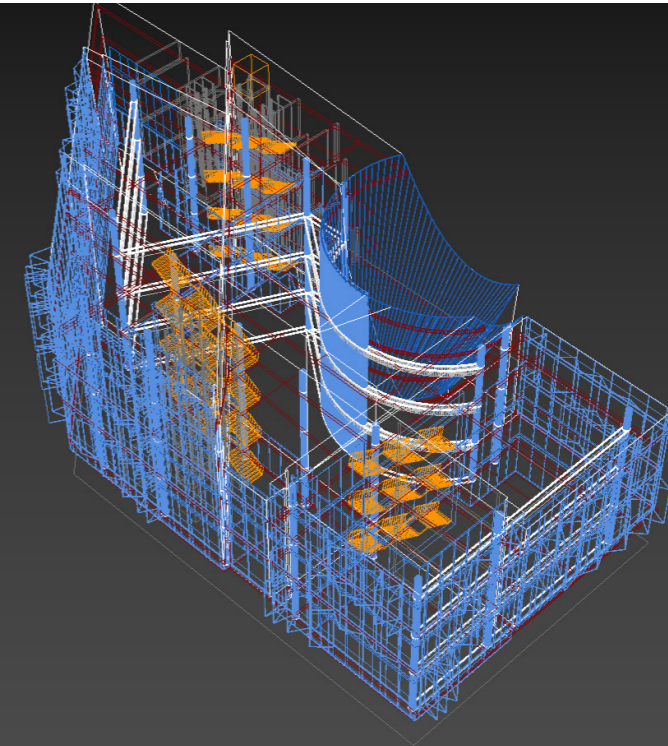
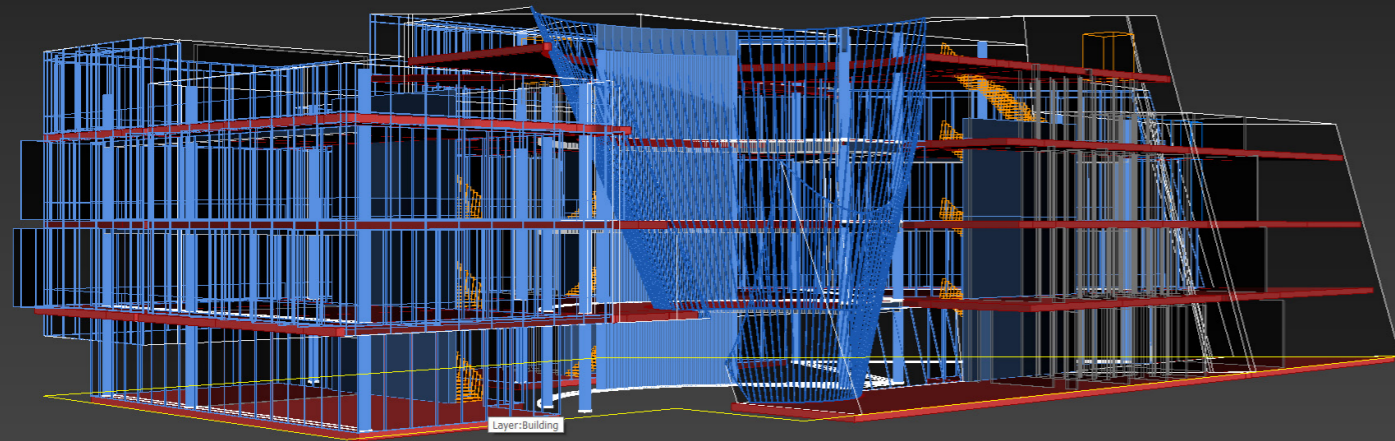
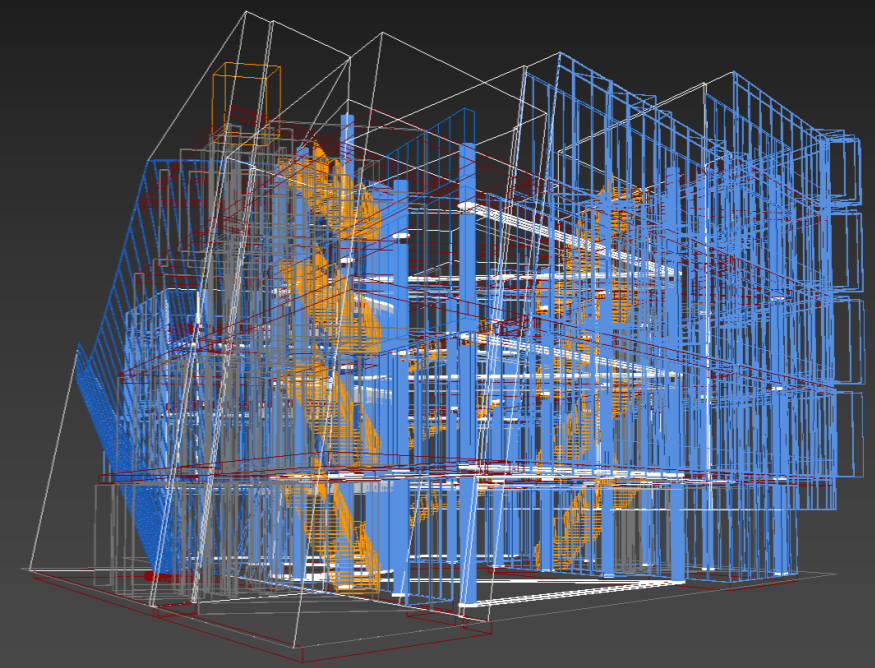
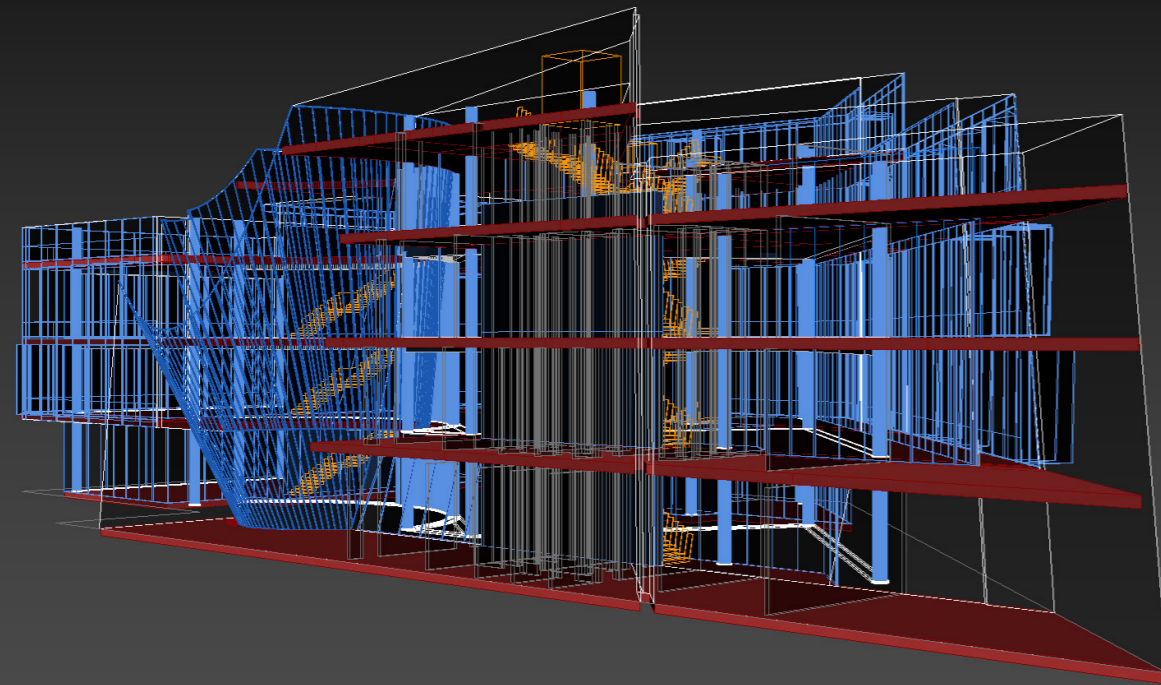

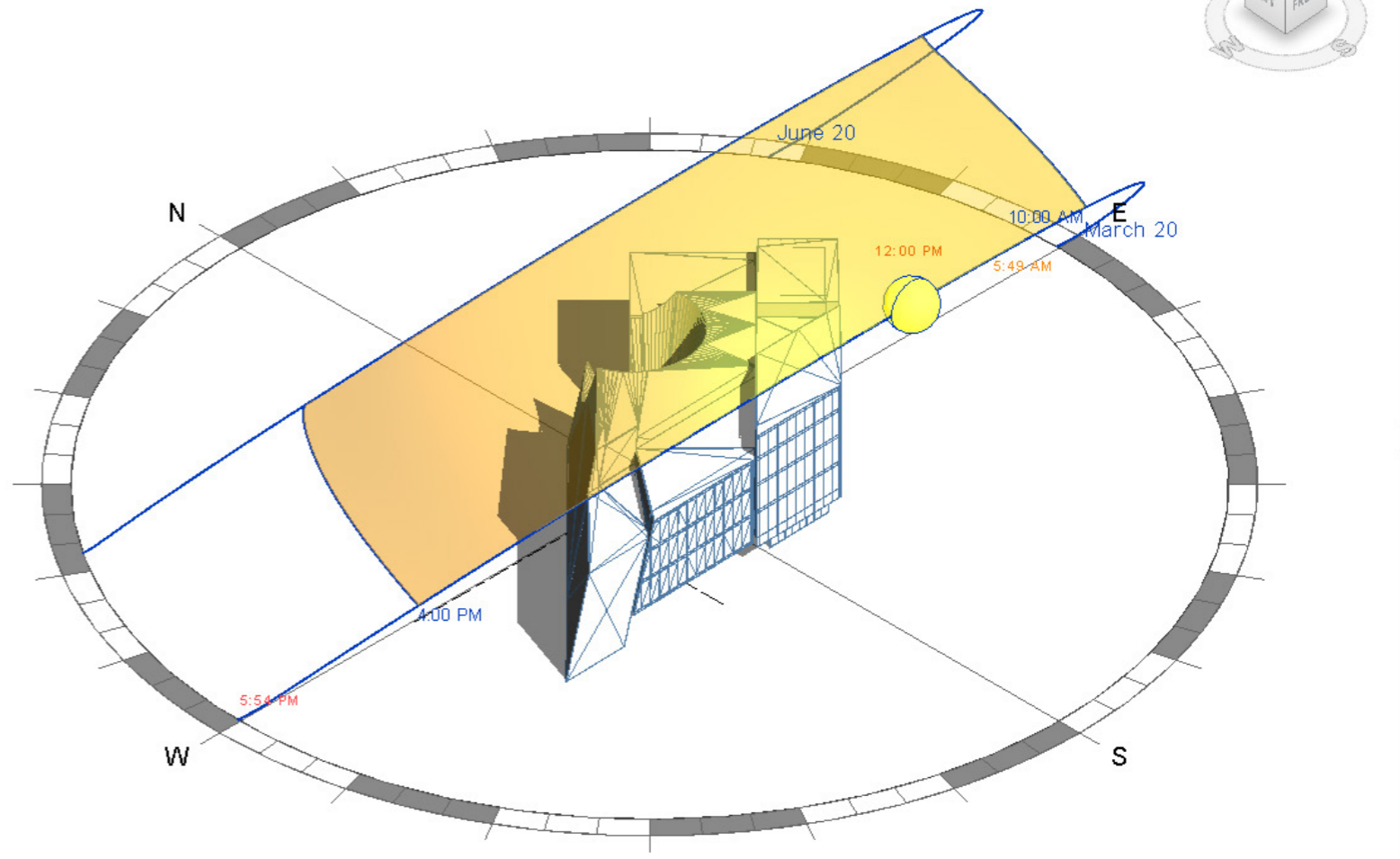
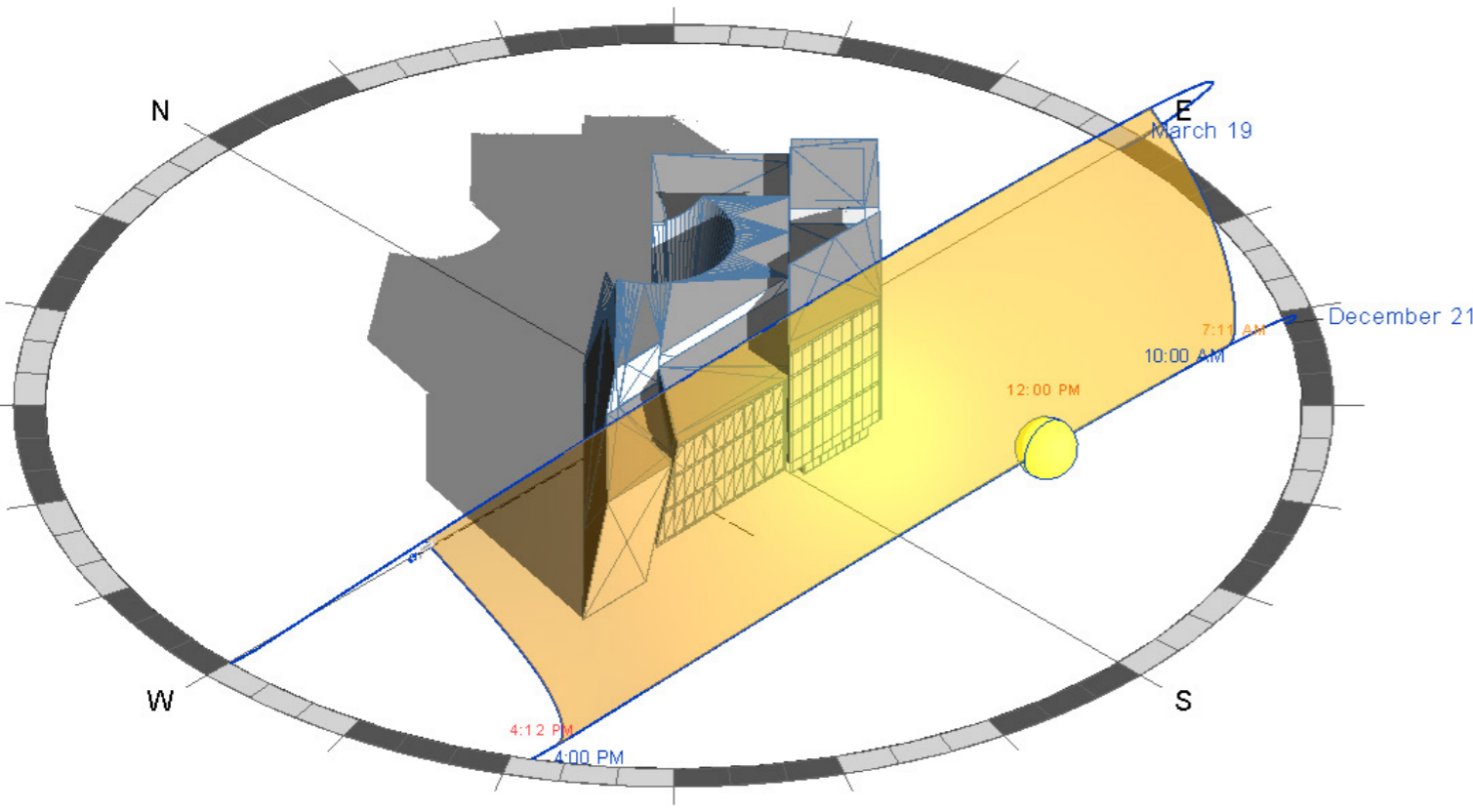
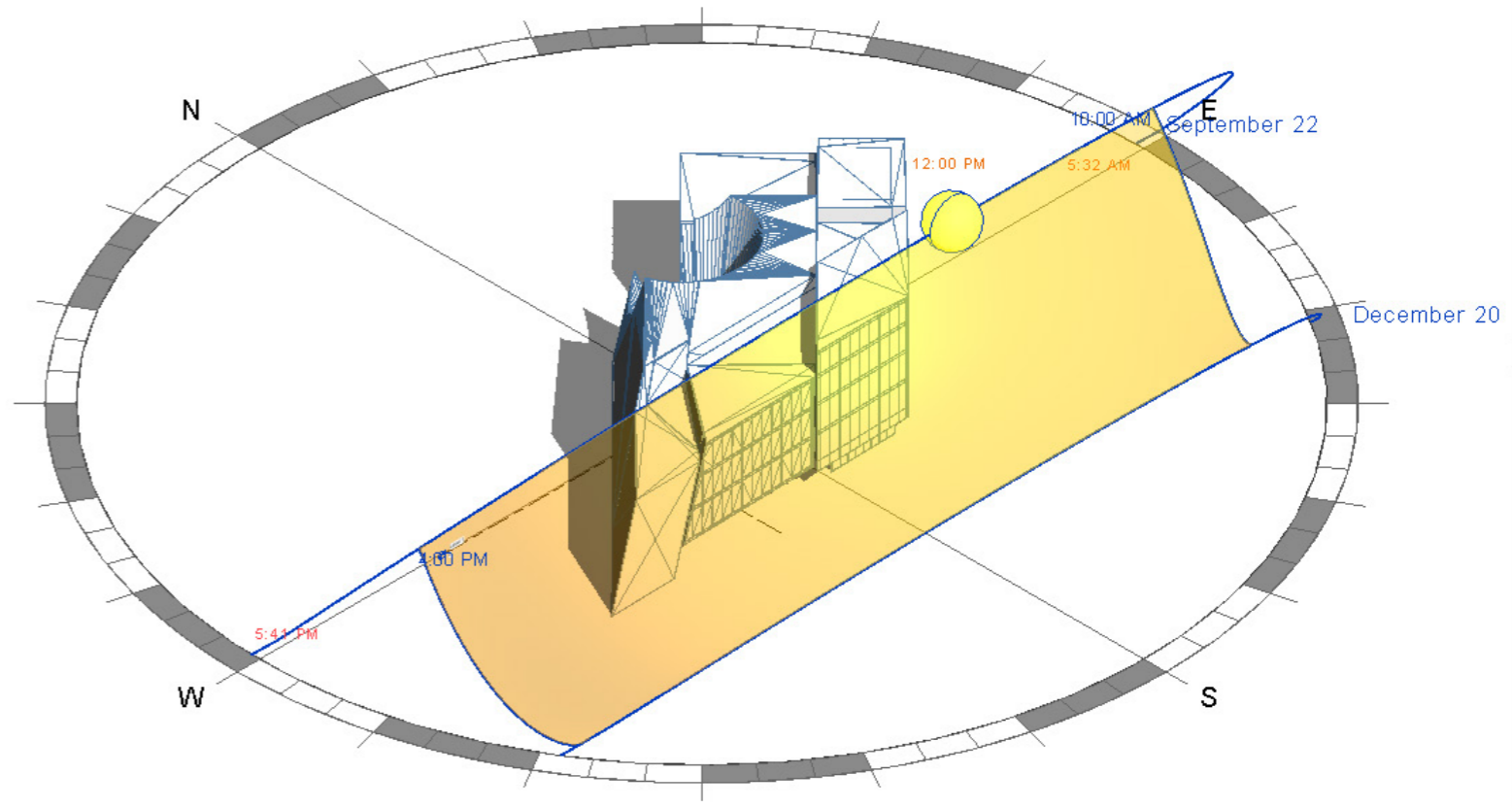
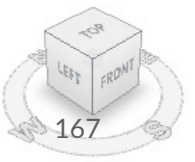
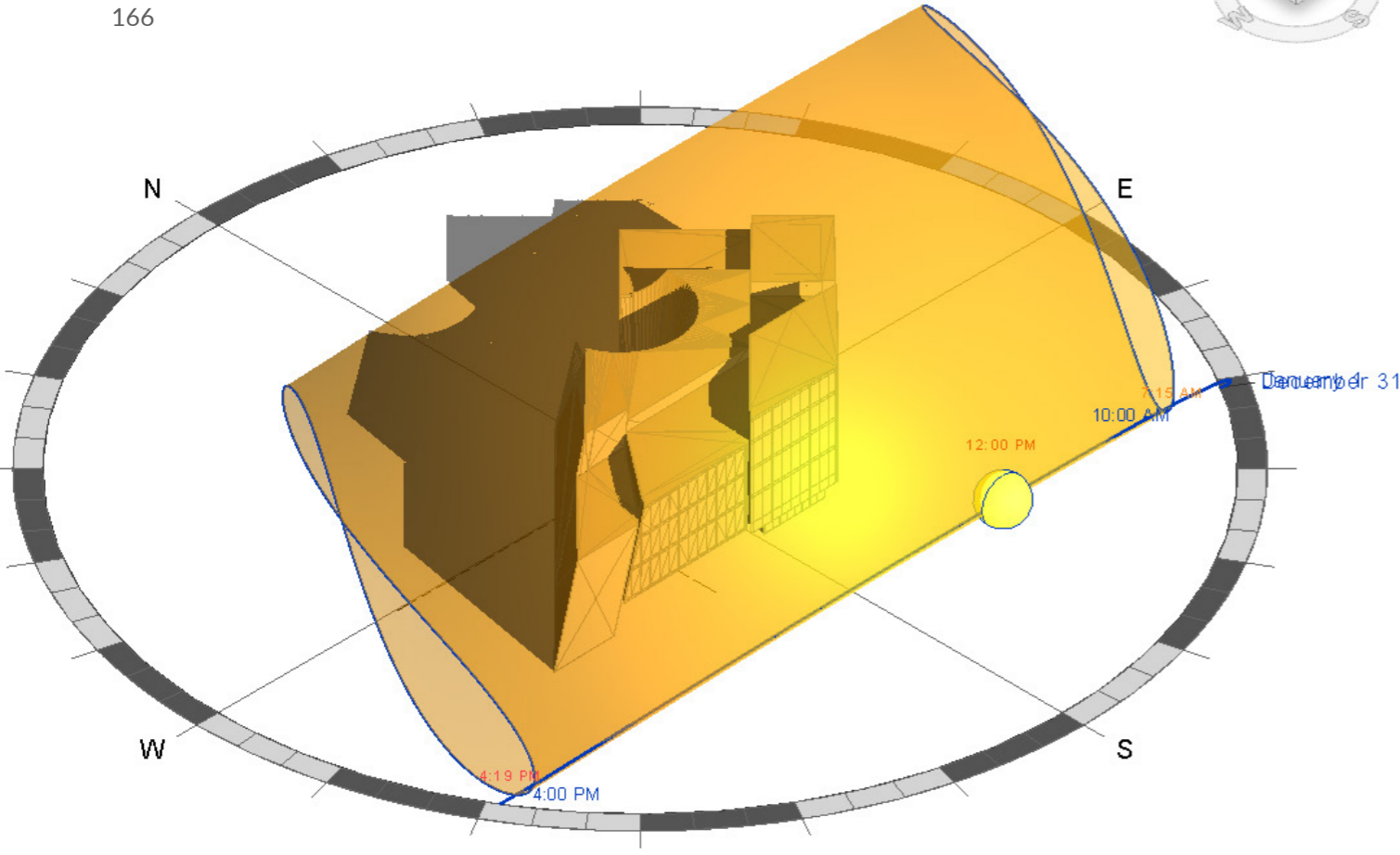

BIM MODEL

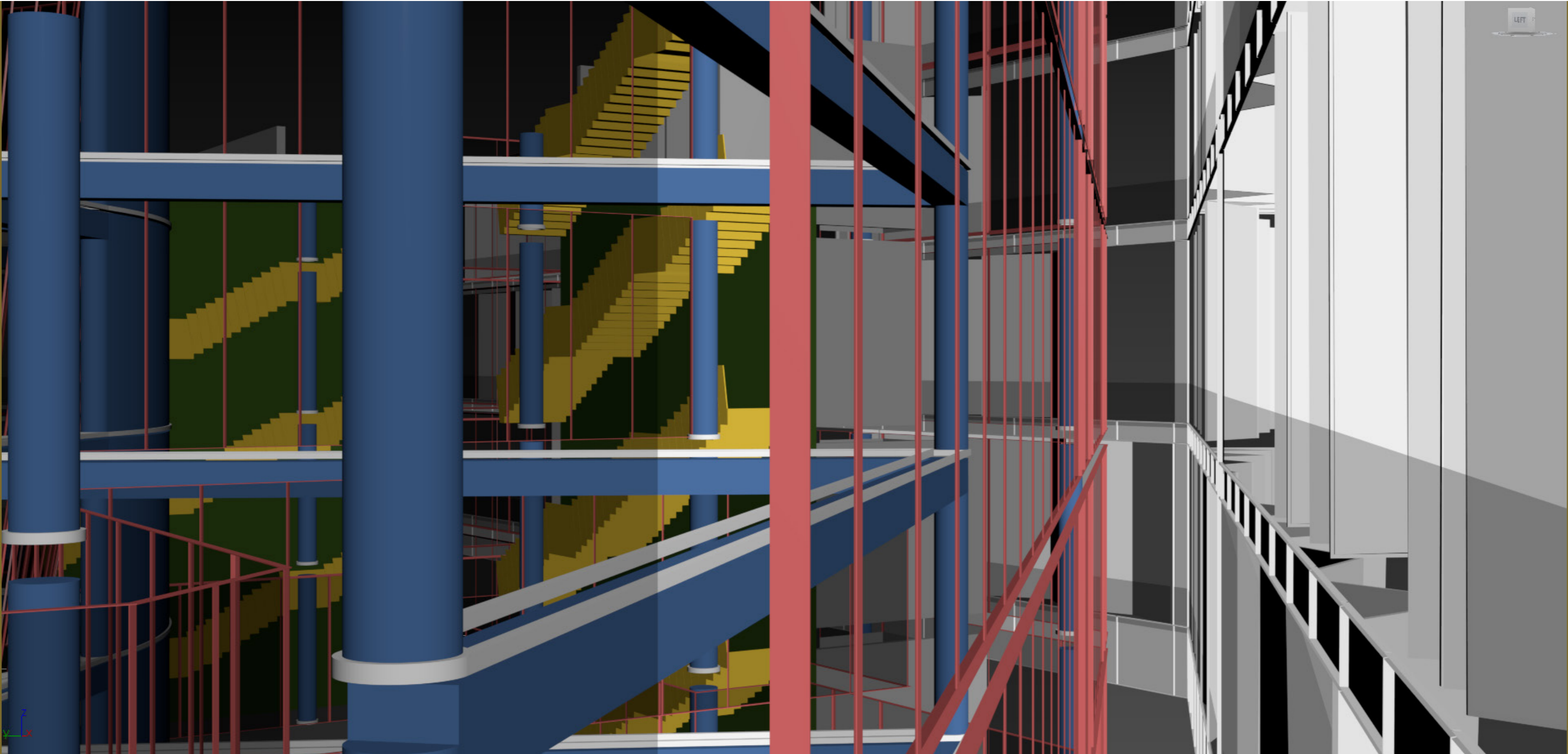

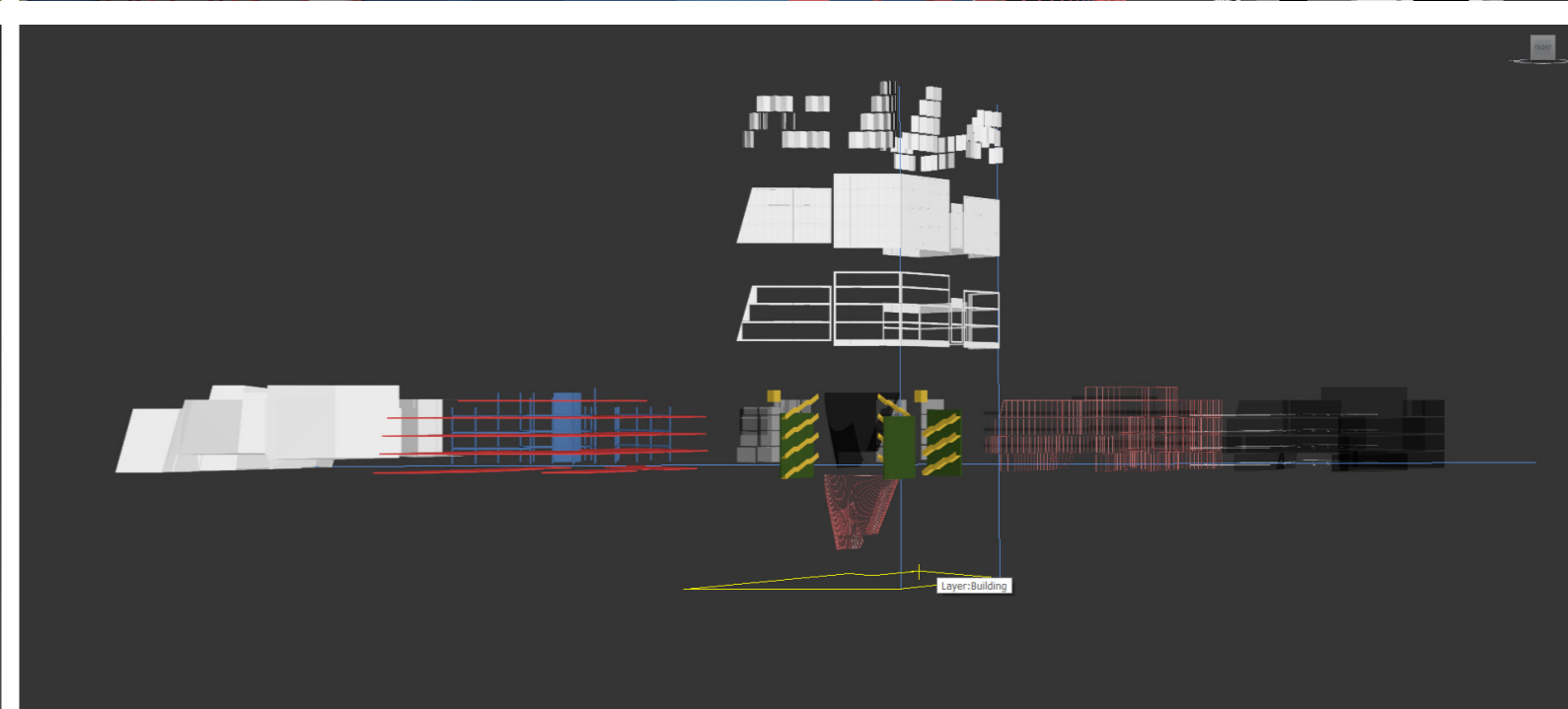
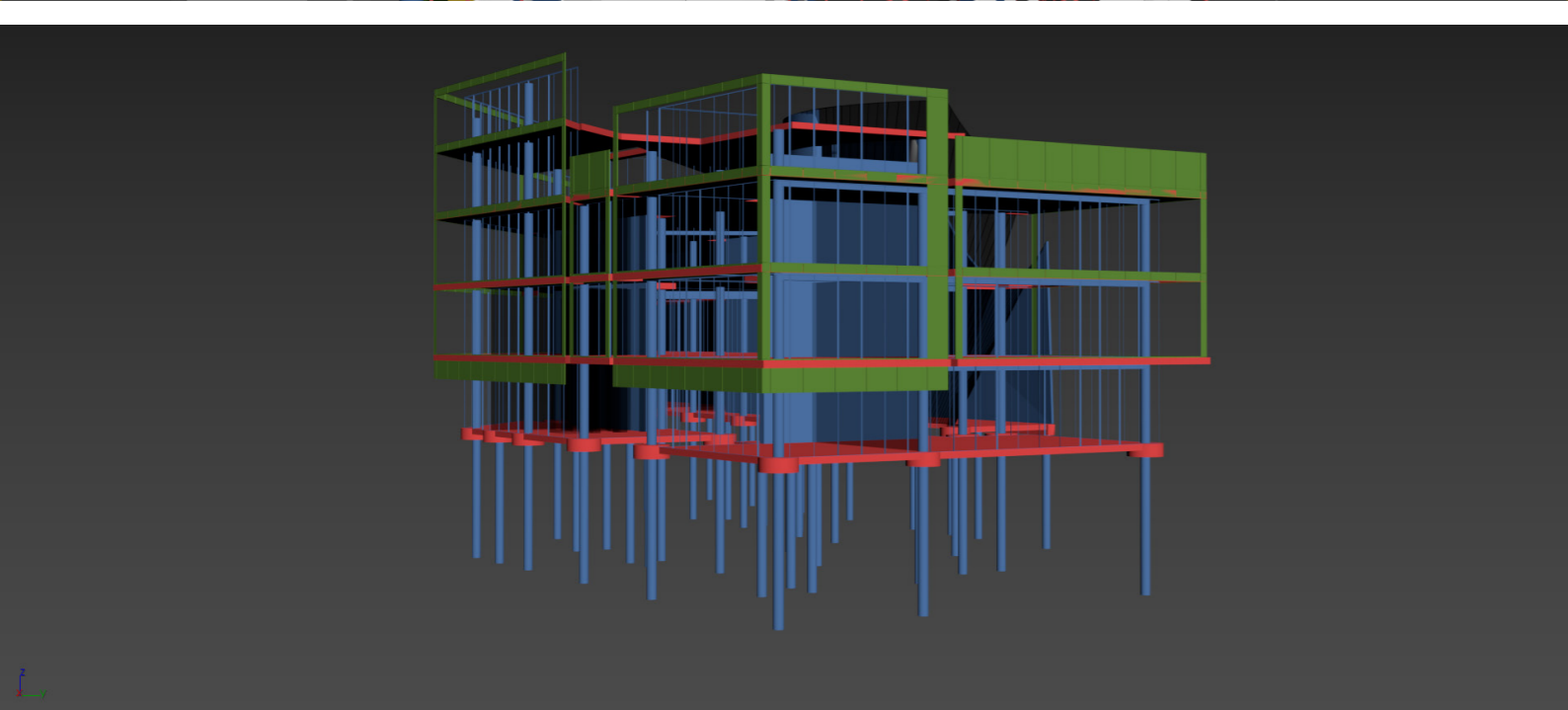
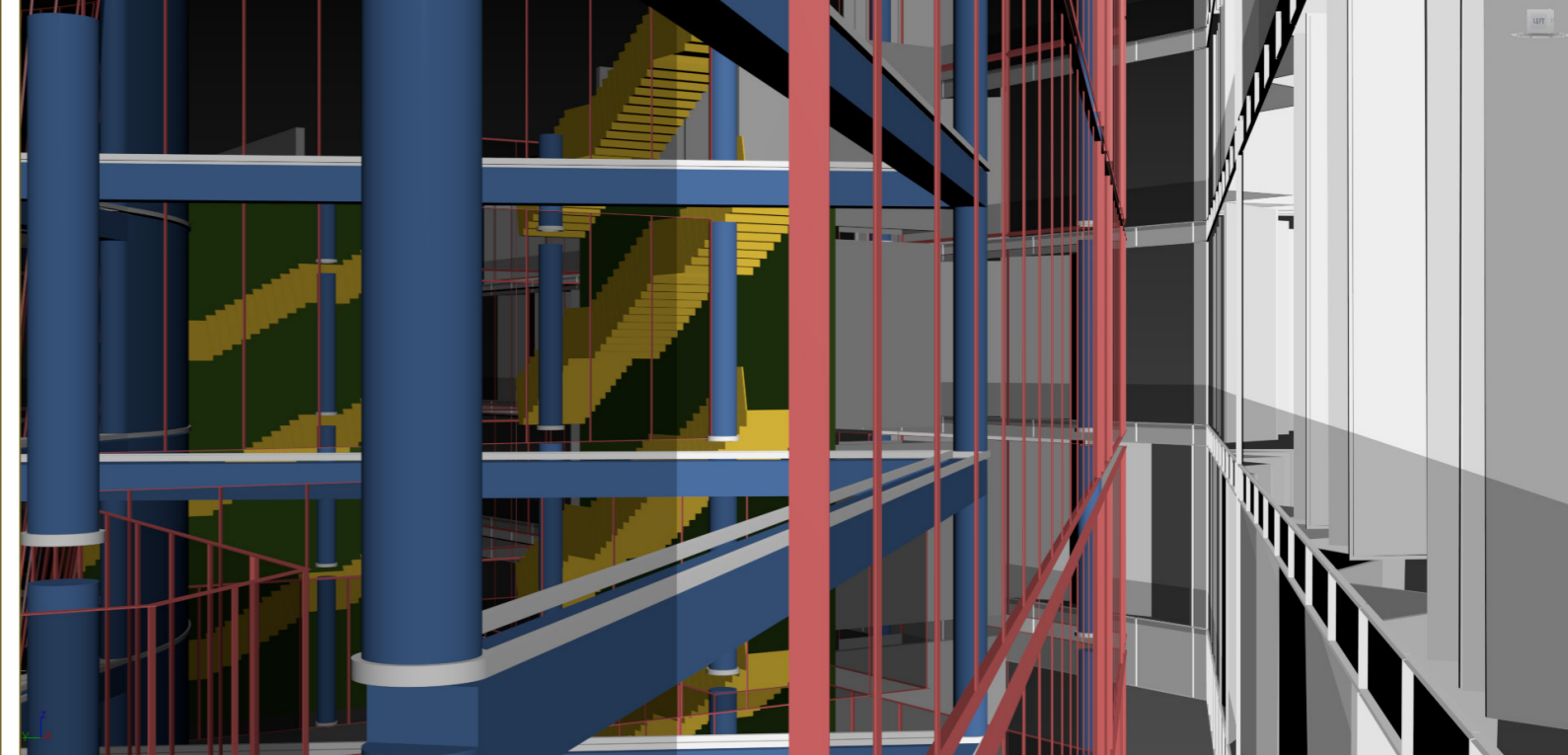
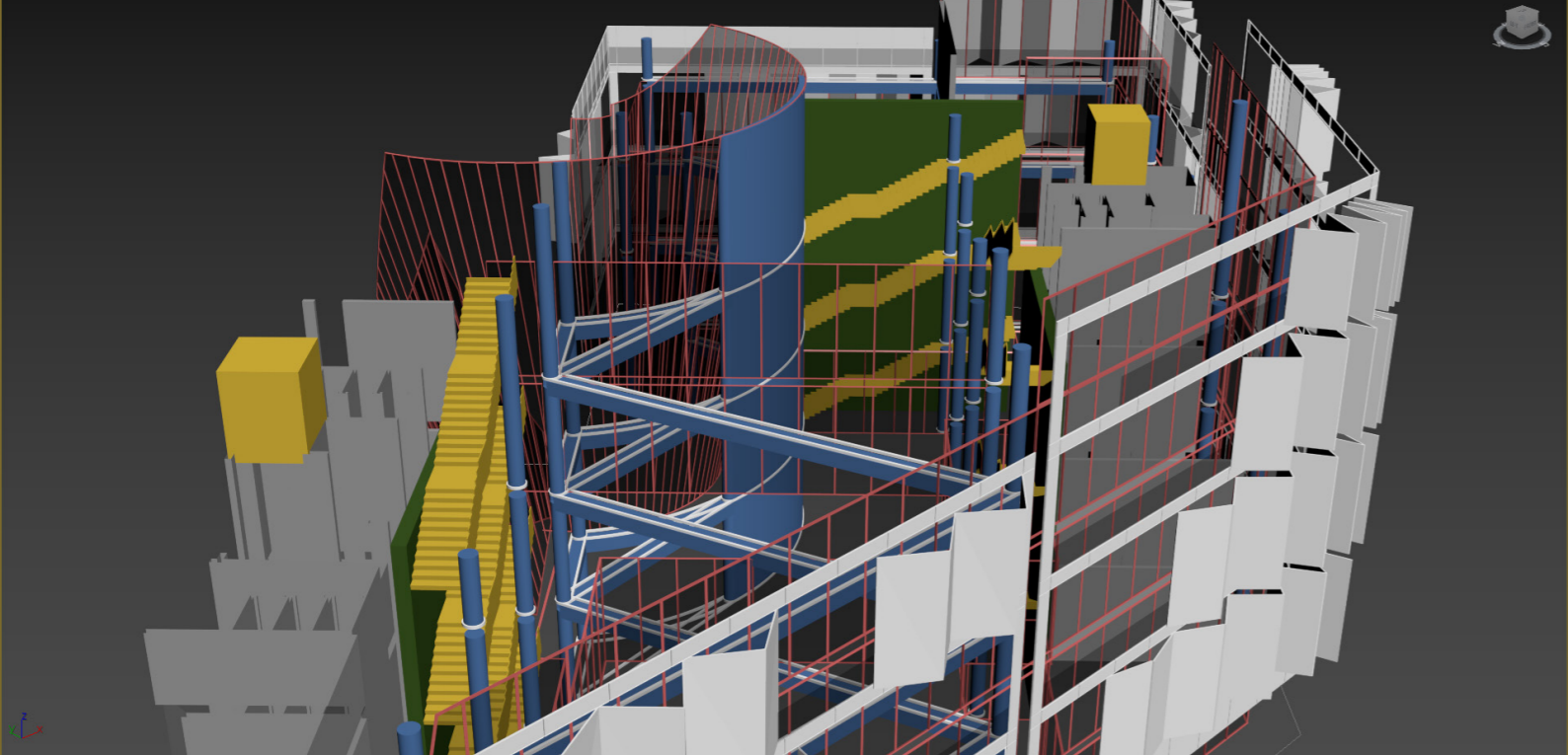
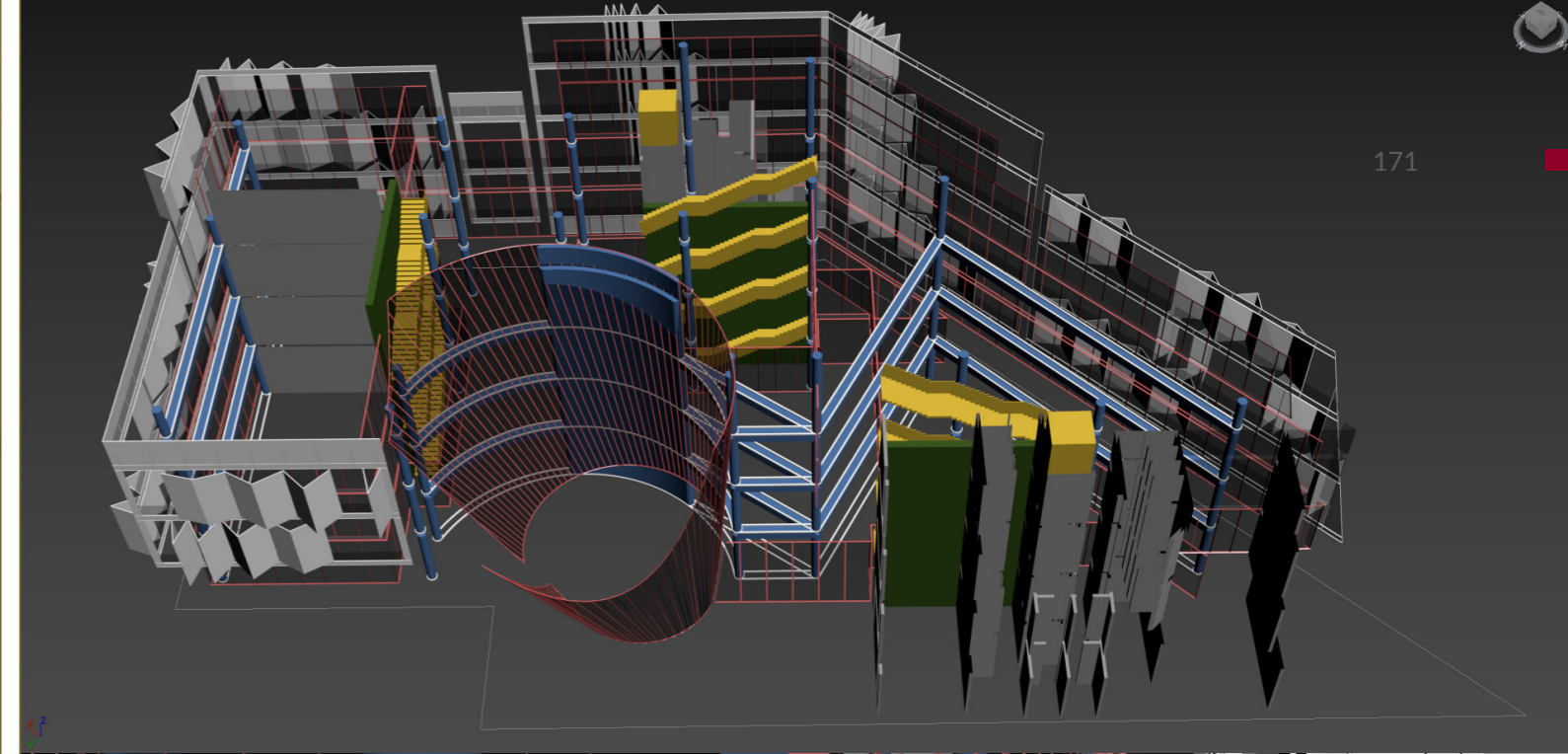
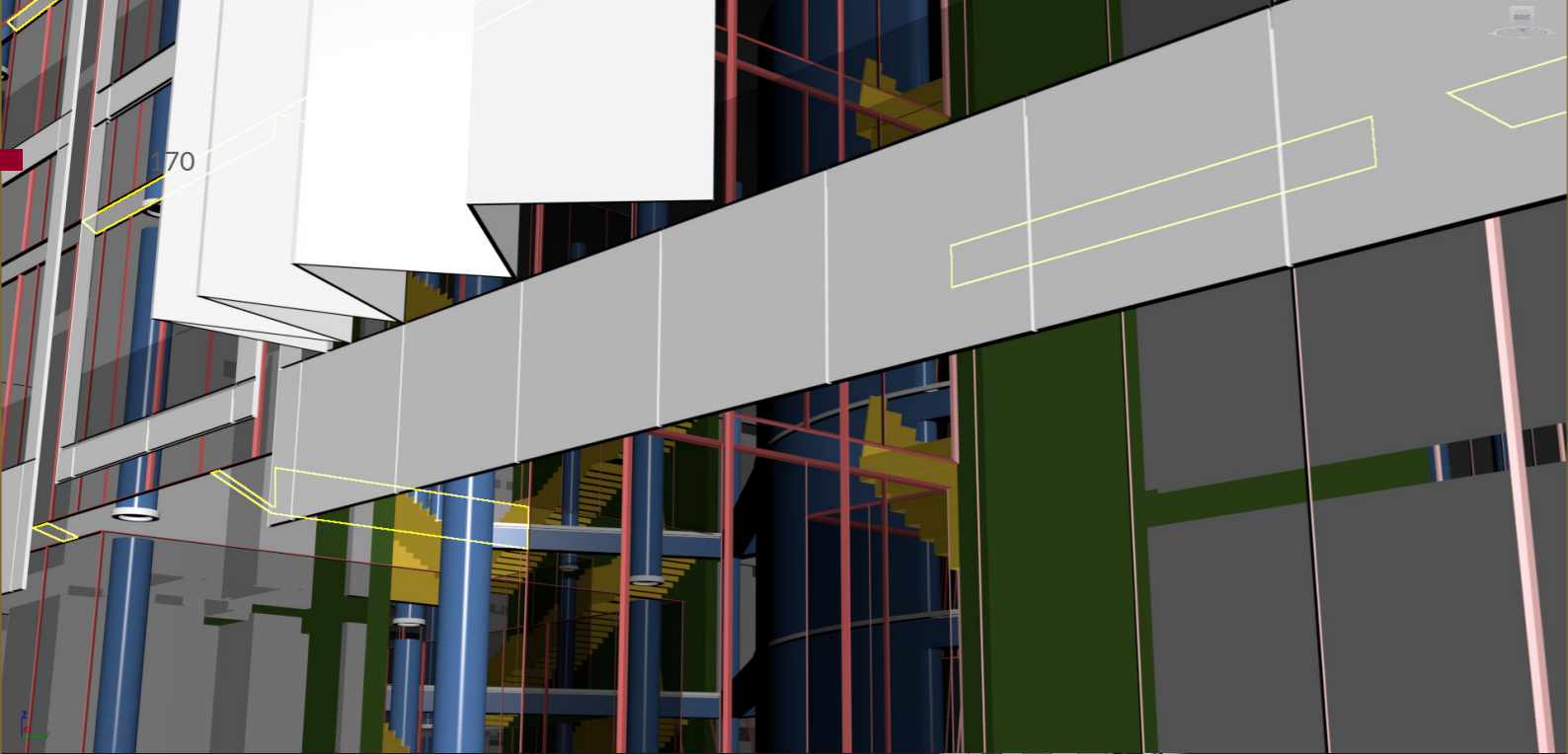

ARCHITECTURAL DIAGRAMS

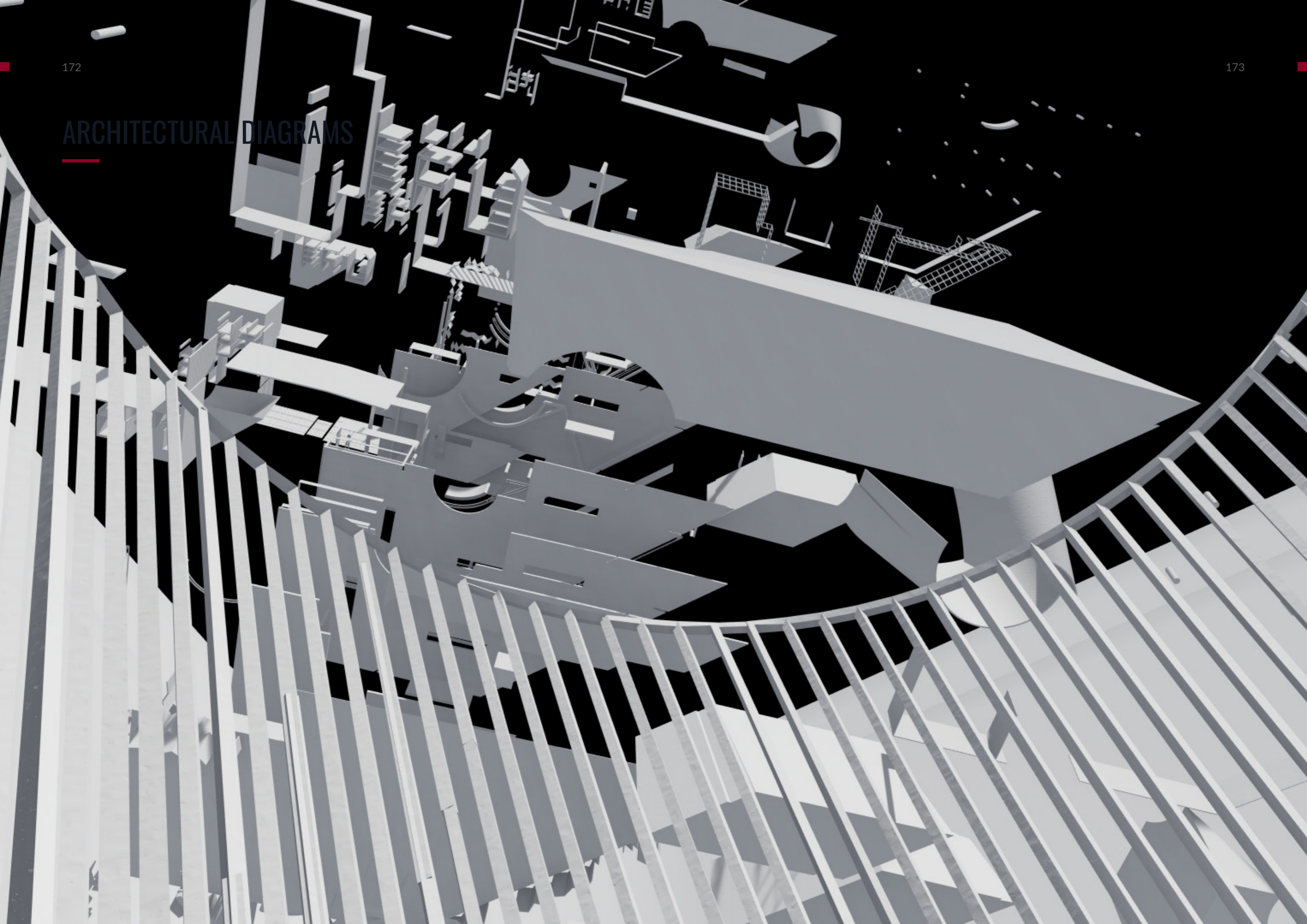

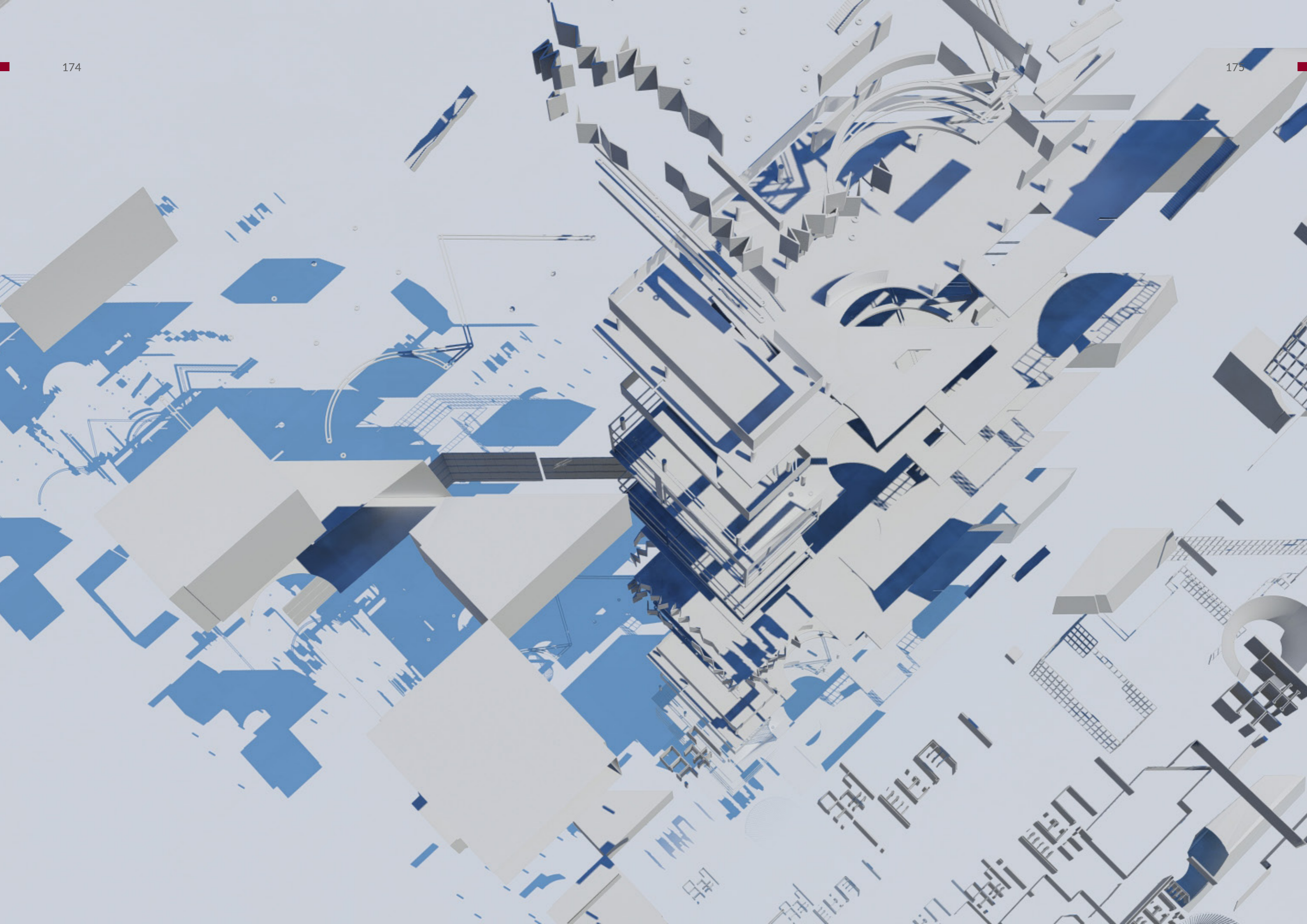

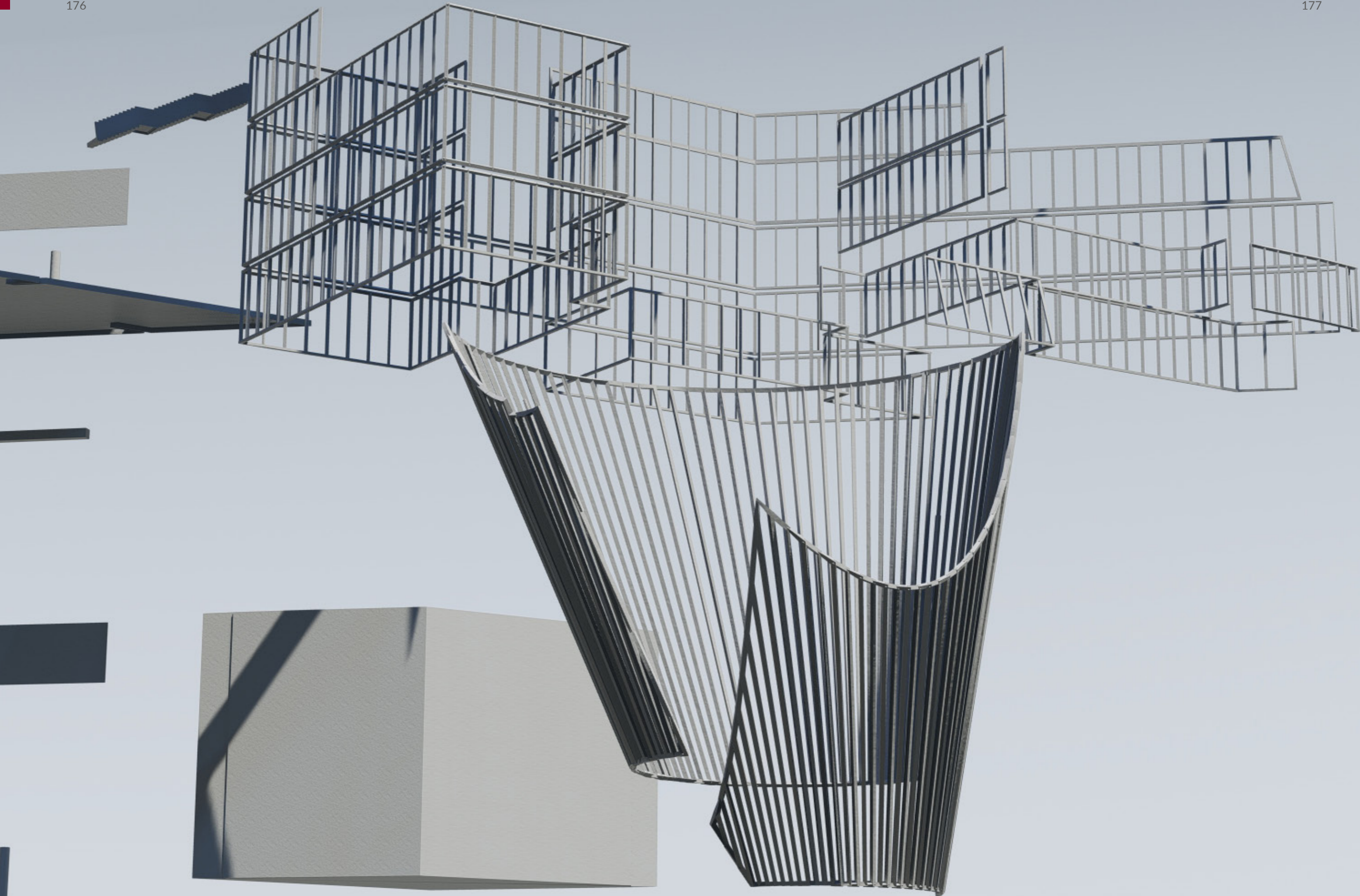

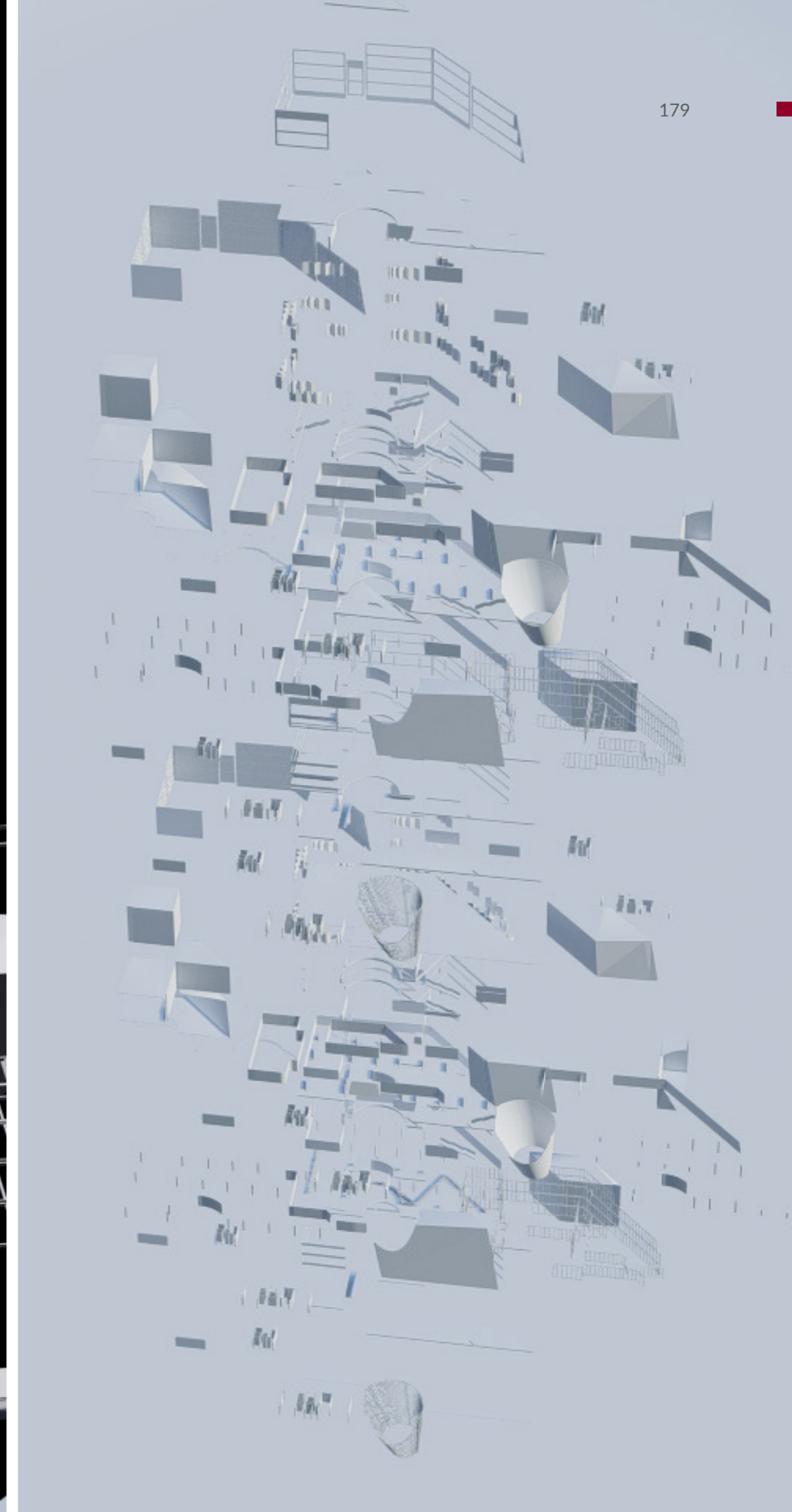
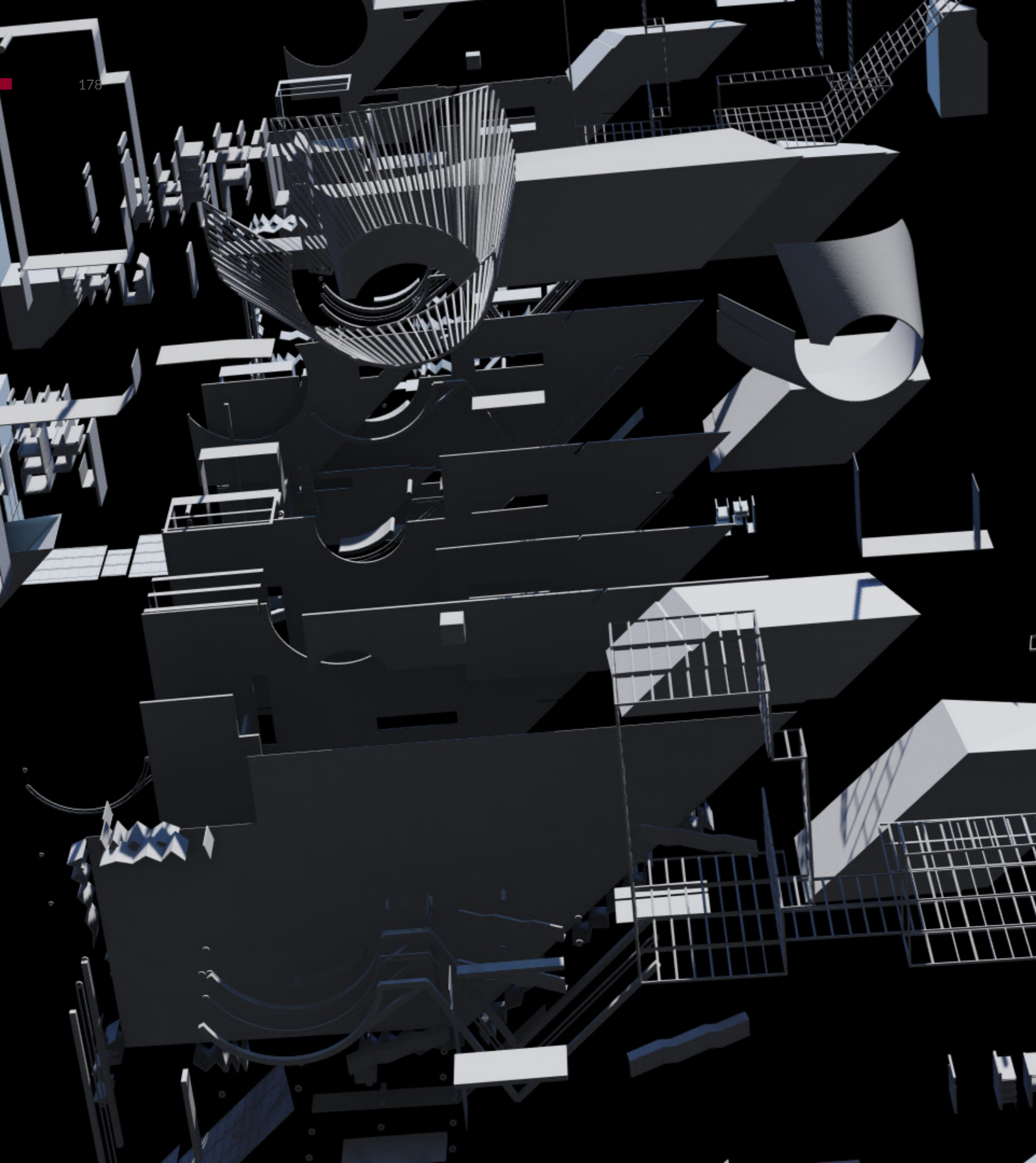

ARCHITECTURAL ZONING DRAWINGS FROM PREVIOUS SUBMISSIONS

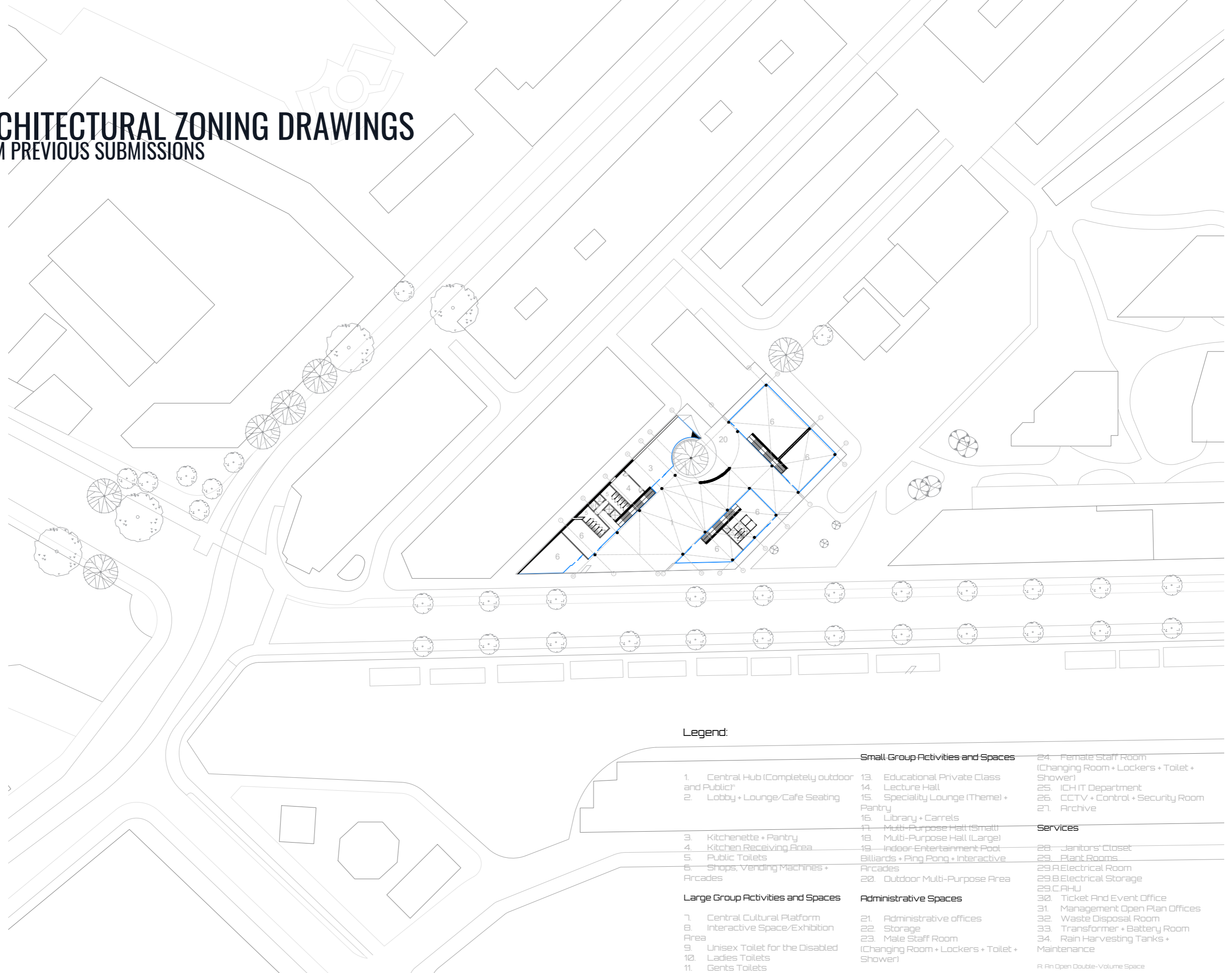

Legend:

- | | | |
|--|---|---|
| 1. Central Hub (Completely outdoor and Public) | 13. Educational Private Class | 24. Female Staff Room (Changing Room + Lockers + Toilet + Shower) |
| 2. Lobby + Lounge/Cafe Seating | 14. Lecture Hall | 25. ICH IT Department |
| 3. Kitchenette + Pantry | 15. Speciality Lounge (Theme) + Pantry | 26. CCTV + Control + Security Room |
| 4. Kitchen Receiving Area | 16. Library + Carrels | 27. Archive |
| 5. Public Toilets | 17. Multi-Purpose Hall (Small) | Services |
| 6. Shops, Vending Machines + Arcades | 18. Multi-Purpose Hall (Large) | 28. Janitors' Closet |
| Large Group Activities and Spaces | 19. Indoor Entertainment Pool | 29. Plant Rooms |
| 7. Central Cultural Platform | Billiards + Ping Pong + Interactive Arcades | 29.A. Electrical Room |
| 8. Interactive Space/Exhibition Area | 20. Outdoor Multi-Purpose Area | 29.B. Electrical Storage |
| 9. Unisex Toilet for the Disabled | Administrative Spaces | 29.C. AHU |
| 10. Ladies Toilets | 21. Administrative offices | 30. Ticket And Event Office |
| 11. Gents Toilets | 22. Storage | 31. Management Open Plan Offices |
| 12. Storage, dressing, and lodging | 23. Male Staff Room (Changing Room + Lockers + Toilet + Shower) | 32. Waste Disposal Room |
| | | 33. Transformer + Battery Room |
| | | 34. Rain Harvesting Tanks + Maintenance |

R: An Open Double-Volume Space



GROUND FLOOR LAYOUT
ICH: INTERNATIONAL COMMUNITY HUB

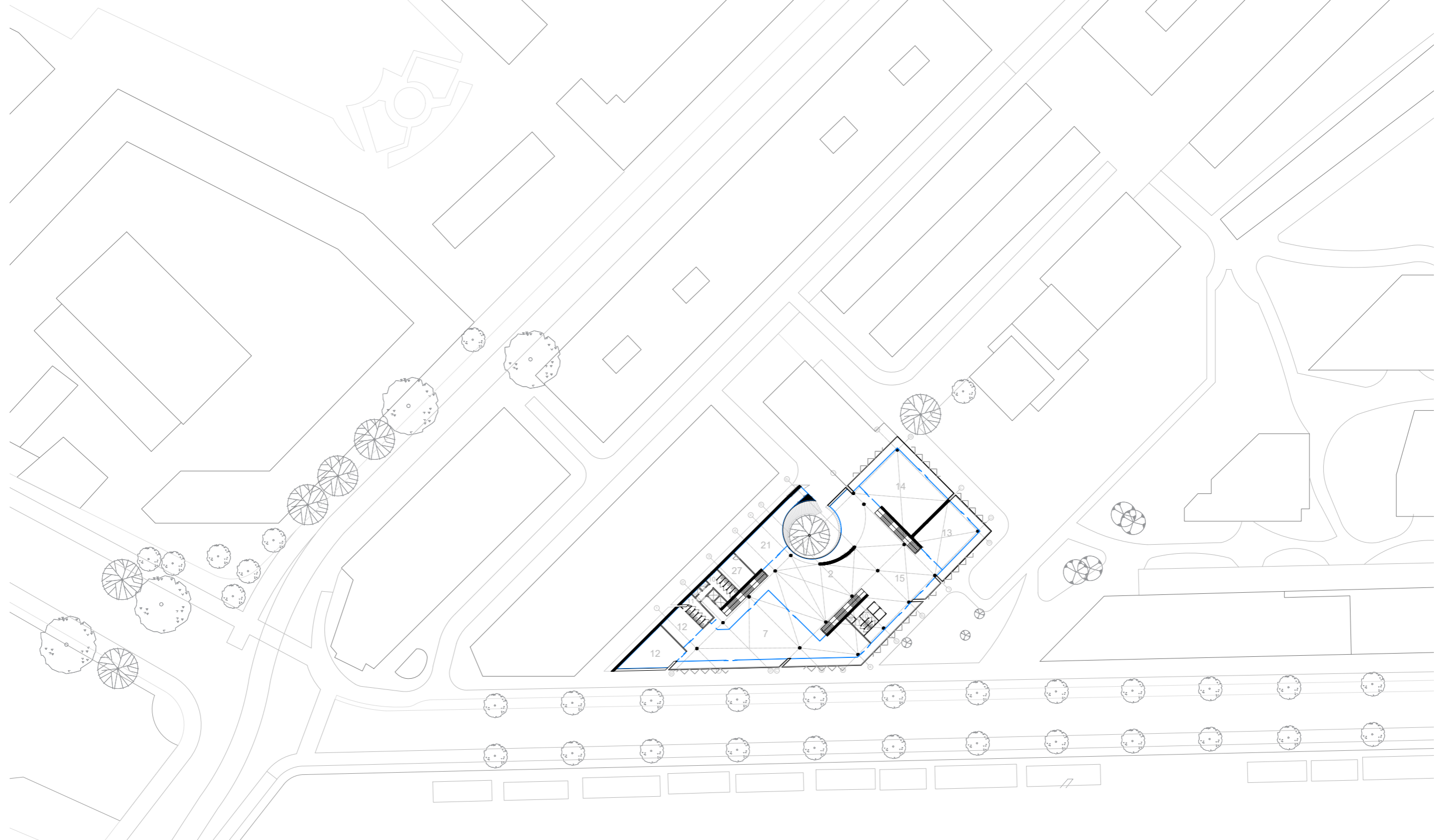

Legend:

- | | | |
|---|---|---|
| 1. Central Hub (Completely outdoor and Public)* | 13. Educational Private Class | 24. Female Staff Room (Changing Room + Lockers + Toilet + Shower) |
| 2. Lobby + Lounge/Cafe Seating | 14. Lecture Hall | 25. ICH IT Department |
| 3. Kitchenette + Pantry | 15. Speciality Lounge (Theme) + Pantry | 26. CCTV + Control + Security Room |
| 4. Kitchen Receiving Area | 16. Library + Carrels | 27. Archive |
| 5. Public Toilets | 17. Multi-Purpose Hall (Small) | |
| 6. Shops, Vending Machines + Arcades | 18. Multi-Purpose Hall (Large) | Services |
| | 19. Indoor Entertainment Pool | 28. Janitors' Closet |
| | Billiards + Ping Pong + Interactive | 29. Plant Rooms |
| | Arcades | 29.A Electrical Room |
| | 20. Outdoor Multi-Purpose Area | 29.B Electrical Storage |
| | | 29.C AHU |
| Large Group Activities and Spaces | Administrative Spaces | 30. Ticket And Event Office |
| 7. Central Cultural Platform | 21. Administrative offices | 31. Management Open Plan Offices |
| 8. Interactive Space/Exhibition Area | 22. Storage | 32. Waste Disposal Room |
| 9. Unisex Toilet for the Disabled | 23. Male Staff Room (Changing Room + Lockers + Toilet + Shower) | 33. Transformer + Battery Room |
| 10. Ladies Toilets | | 34. Rain Harvesting Tanks + Maintenance |
| 11. Gents Toilets | | |
| 12. Storage, dressing, and lodging | | |

R: An Open Double-Volume Space

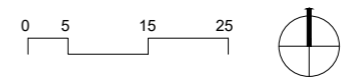

FIRST FLOOR LAYOUT
ICH: INTERNATIONAL COMMUNITY HUB

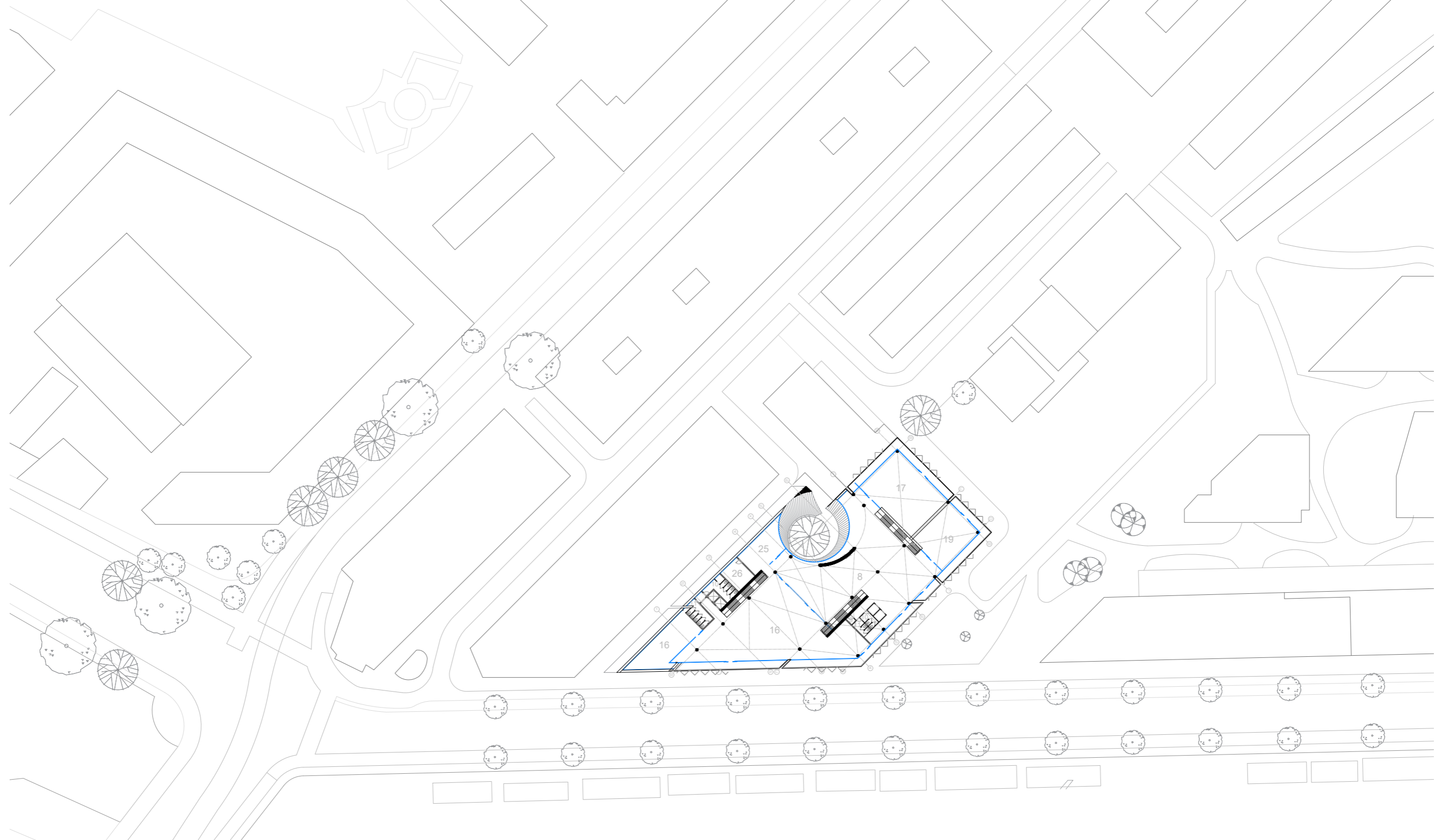

Legend:

- | | | |
|--|---|---|
| 1. Central Hub (Completely outdoor and Public) | 13. Educational Private Class | 24. Female Staff Room (Changing Room + Lockers + Toilet + Shower) |
| 2. Lobby + Lounge/Cafe Seating | 14. Lecture Hall | 25. ICH IT Department |
| 3. Kitchenette + Pantry | 15. Speciality Lounge (Theme) + Pantry | 26. CCTV + Control + Security Room |
| 4. Kitchen Receiving Area | 16. Library + Carrels | 27. Archive |
| 5. Public Toilets | 17. Multi-Purpose Hall (Small) | Services |
| 6. Shops, Vending Machines + Arcades | 18. Multi-Purpose Hall (Large) | 28. Janitors' Closet |
| Large Group Activities and Spaces | 19. Indoor Entertainment Pool | 29. Plant Rooms |
| 7. Central Cultural Platform | Billiards + Ping Pong + Interactive Arcades | 29.A. Electrical Room |
| 8. Interactive Space/Exhibition Area | 20. Outdoor Multi-Purpose Area | 29.B. Electrical Storage |
| 9. Unisex Toilet for the Disabled | Administrative Spaces | 29.C. AHU |
| 10. Ladies Toilets | 21. Administrative offices | 30. Ticket And Event Office |
| 11. Gents Toilets | 22. Storage | 31. Management Open Plan Offices |
| 12. Storage, dressing, and lodging | 23. Male Staff Room (Changing Room + Lockers + Toilet + Shower) | 32. Waste Disposal Room |
| | | 33. Transformer + Battery Room |
| | | 34. Rain Harvesting Tanks + Maintenance |

R: An Open Double-Volume Space



SECOND FLOOR LAYOUT
 ICH: INTERNATIONAL COMMUNITY HUB

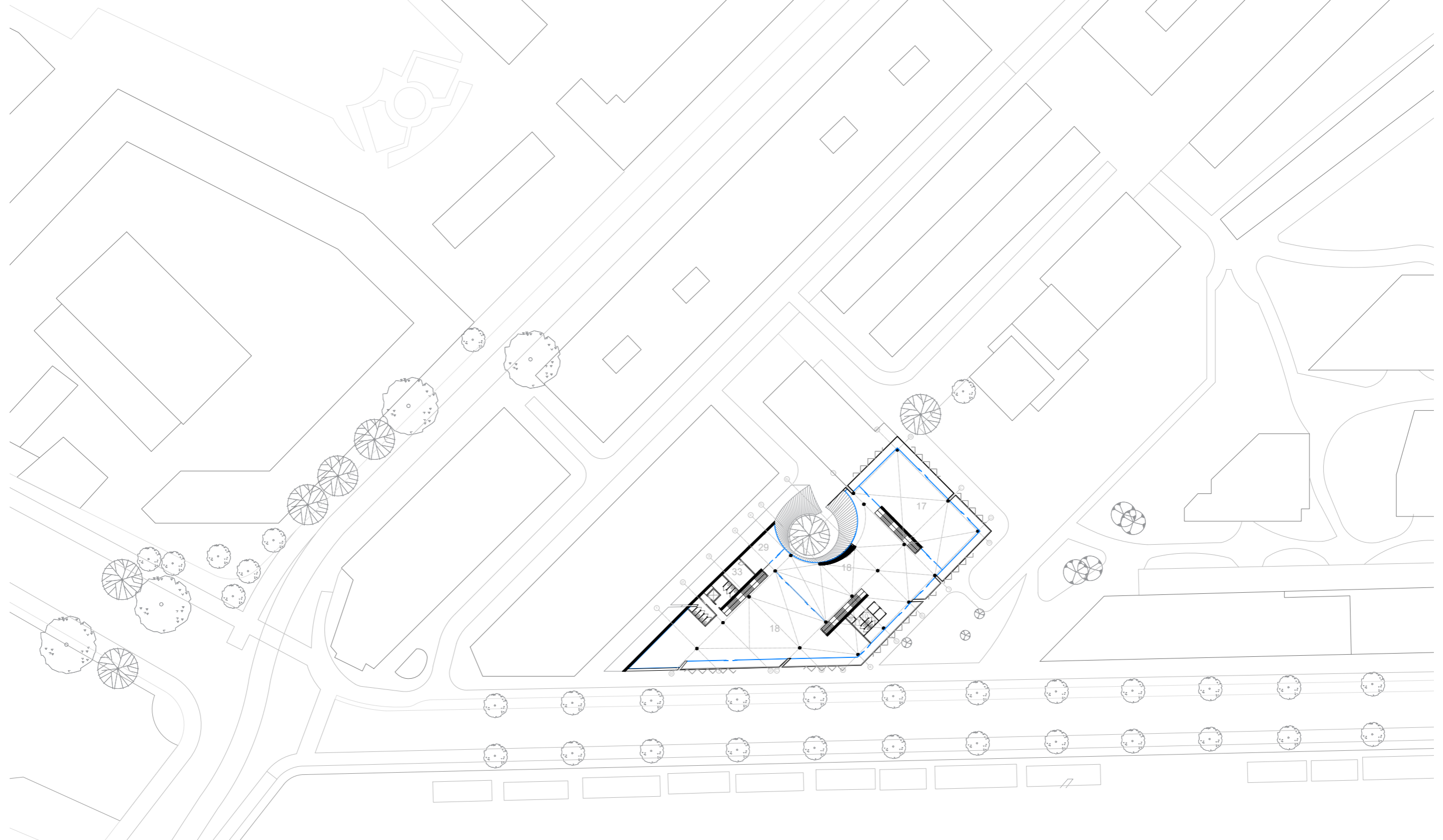

Legend:

- | | | |
|---|--|---|
| 1. Central Hub (Completely outdoor and Public)* | 13. Educational Private Class | 24. Female Staff Room (Changing Room + Lockers + Toilet + Shower) |
| 2. Lobby + Lounge/Cafe Seating | 14. Lecture Hall | 25. ICH IT Department |
| 3. Kitchenette + Pantry | 15. Speciality Lounge (Theme) + Pantry | 26. CCTV + Control + Security Room |
| 4. Kitchen Receiving Area | 16. Library + Carrels | 27. Archive |
| 5. Public Toilets | 17. Multi-Purpose Hall (Small) | |
| 6. Shops, Vending Machines + Arcades | 18. Multi-Purpose Hall (Large) | Services |
| | 19. Indoor Entertainment Pool | 28. Janitors' Closet |
| | 20. Outdoor Multi-Purpose Area | 29. Plant Rooms |
| | | 29.A Electrical Room |
| | | 29.B Electrical Storage |
| | | 29.C AHU |
| | | 30. Ticket And Event Office |
| | | 31. Management Open Plan Offices |
| | | 32. Waste Disposal Room |
| | | 33. Transformer + Battery Room |
| | | 34. Rain Harvesting Tanks + Maintenance |
| | | R: An Open Double-Volume Space |

Large Group Activities and Spaces

- 7. Central Cultural Platform
- 8. Interactive Space/Exhibition Area
- 9. Unisex Toilet for the Disabled
- 10. Ladies Toilets
- 11. Gents Toilets
- 12. Storage, dressing, and lodging

Administrative Spaces

- 21. Administrative offices
- 22. Storage
- 23. Male Staff Room (Changing Room + Lockers + Toilet + Shower)



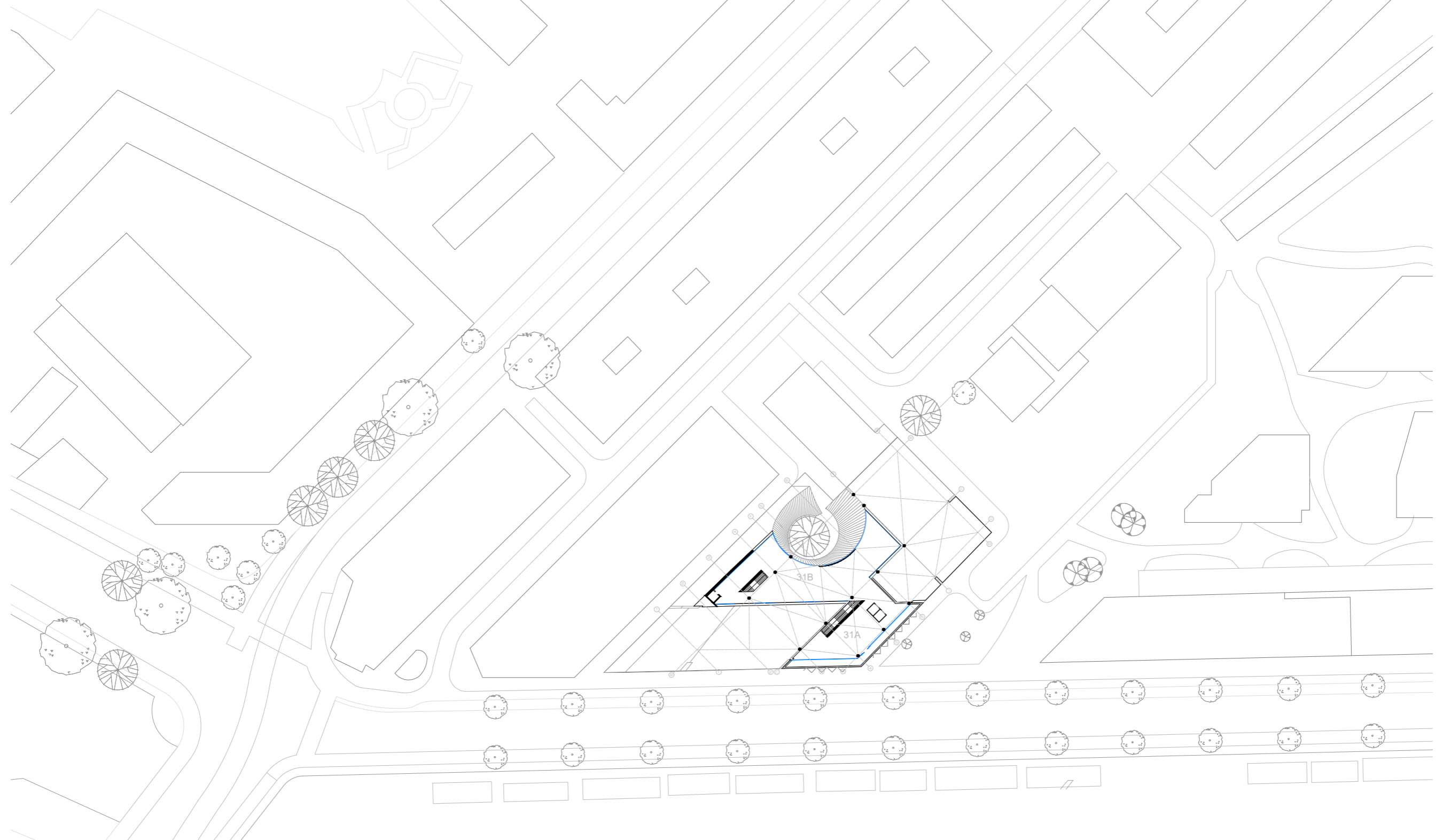

Legend:

- | | | |
|--|---|---|
| 1. Central Hub (Completely outdoor and Public) | 13. Educational Private Class | 24. Female Staff Room (Changing Room + Lockers + Toilet + Shower) |
| 2. Lobby + Lounge/Cafe Seating | 14. Lecture Hall | 25. ICH IT Department |
| 3. Kitchenette + Pantry | 15. Speciality Lounge (Theme) + Pantry | 26. CCTV + Control + Security Room |
| 4. Kitchen Receiving Area | 16. Library + Carrels | 27. Archive |
| 5. Public Toilets | 17. Multi-Purpose Hall (Small) | Services |
| 6. Shops, Vending Machines + Arcades | 18. Multi-Purpose Hall (Large) | 28. Janitors' Closet |
| Large Group Activities and Spaces | 19. Indoor Entertainment Pool | 29. Plant Rooms |
| 7. Central Cultural Platform | Billiards + Ping Pong + Interactive Arcades | 29.A. Electrical Room |
| 8. Interactive Space/Exhibition Area | 20. Outdoor Multi-Purpose Area | 29.B. Electrical Storage |
| 9. Unisex Toilet for the Disabled | Administrative Spaces | 29.C. AHU |
| 10. Ladies Toilets | 21. Administrative offices | 30. Ticket And Event Office |
| 11. Gents Toilets | 22. Storage | 31. Management Open Plan Offices |
| 12. Storage, dressing, and lodging | 23. Male Staff Room (Changing Room + Lockers + Toilet + Shower) | 32. Waste Disposal Room |
| | | 33. Transformer + Battery Room |
| | | 34. Rain Harvesting Tanks + Maintenance |
- R: An Open Double-Volume Space



FOURTH FLOOR LAYOUT
ICH: INTERNATIONAL COMMUNITY HUB

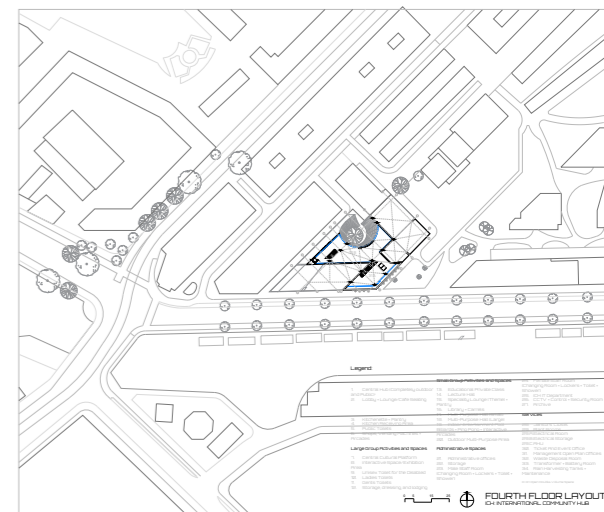
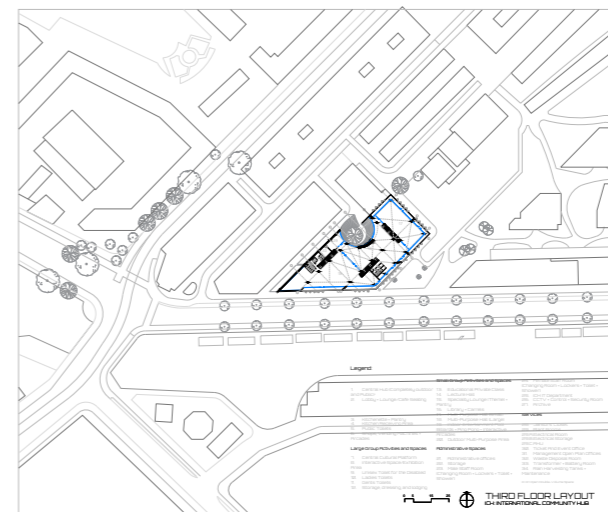
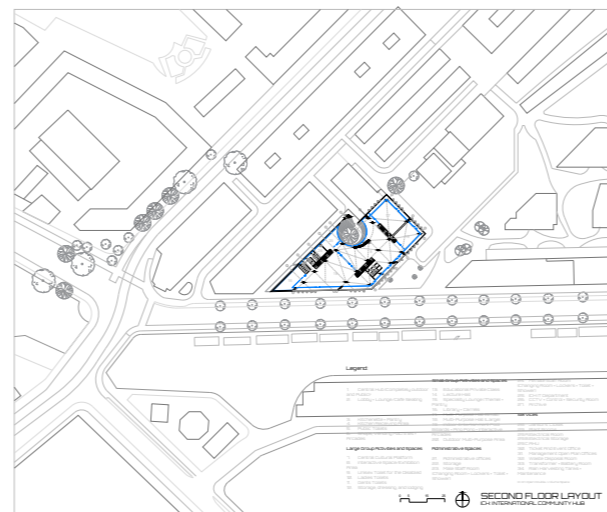
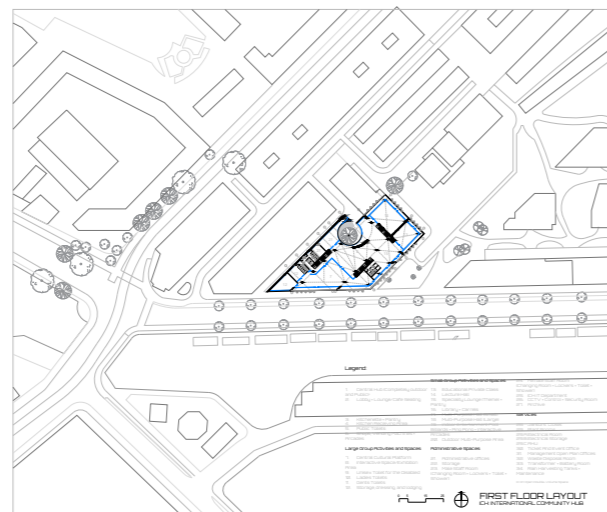
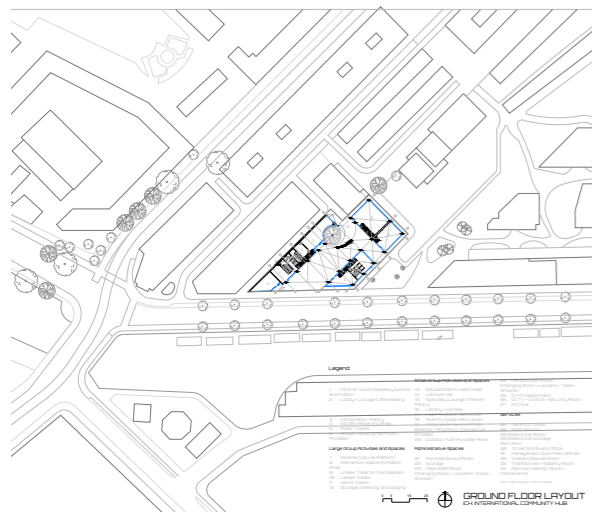
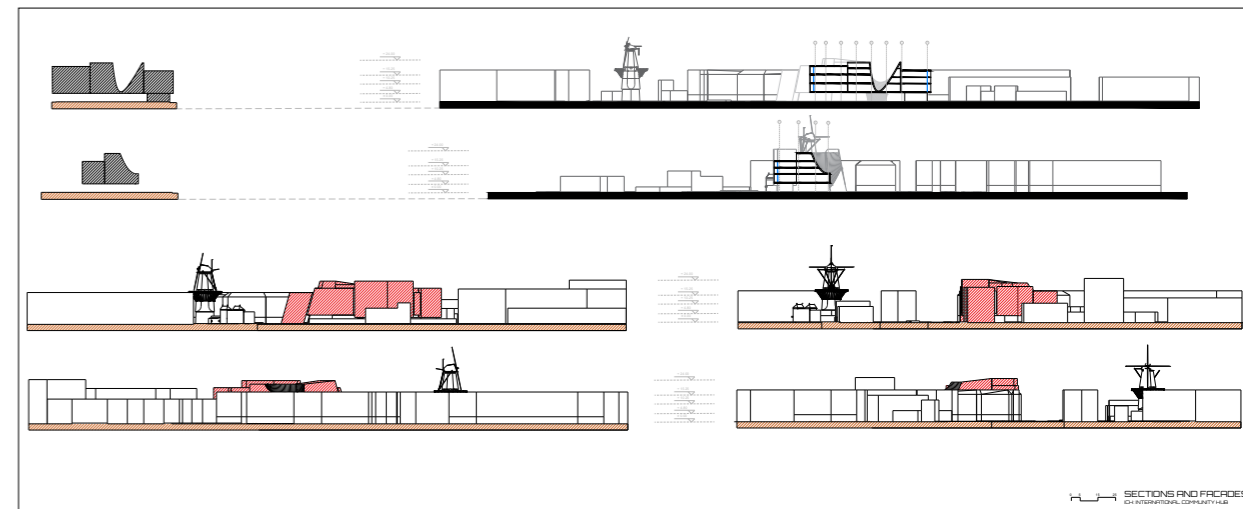
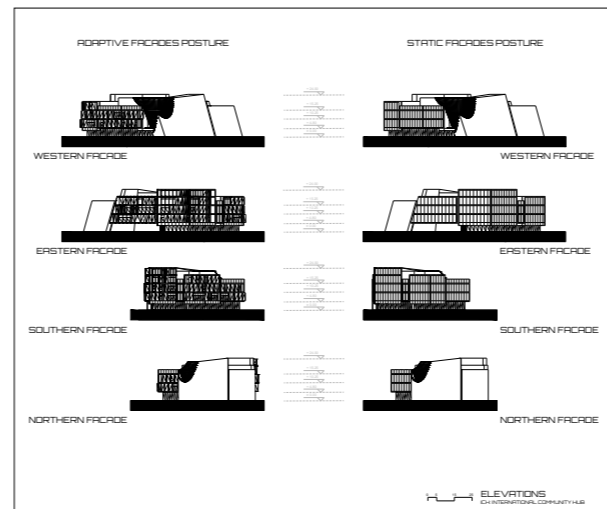
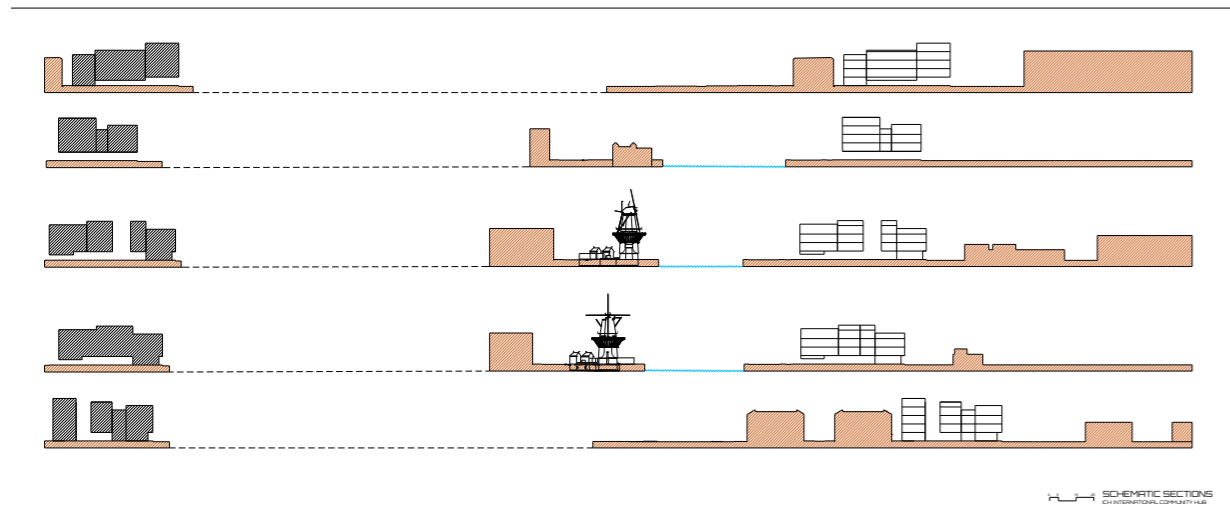
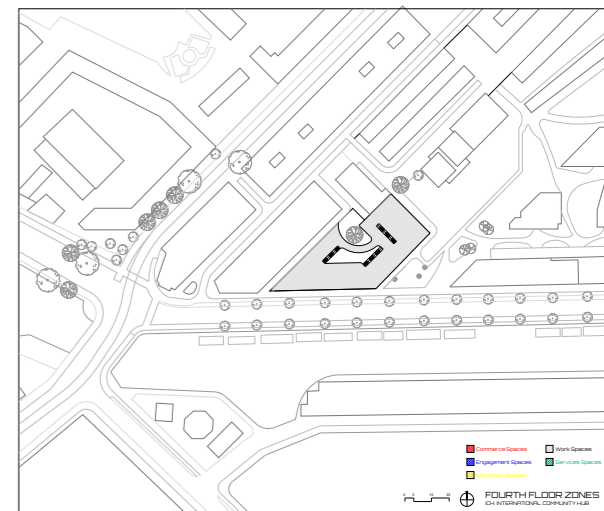
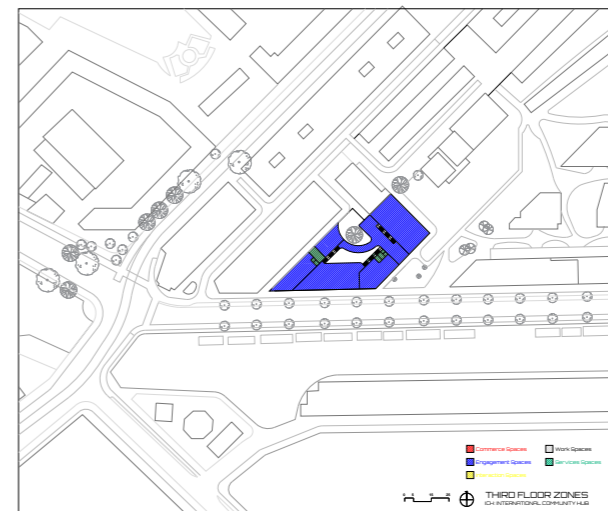
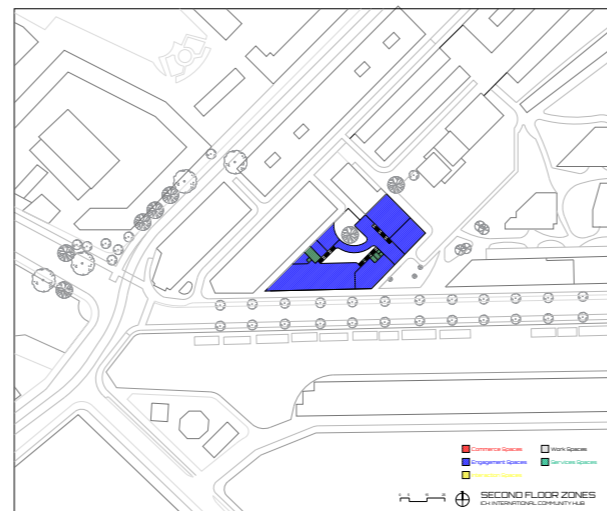
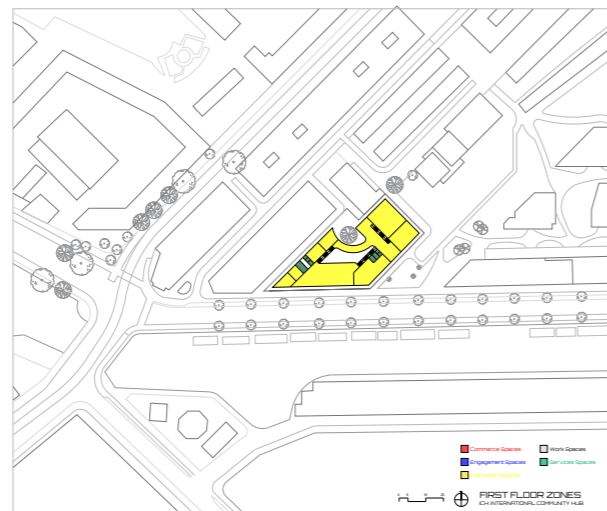
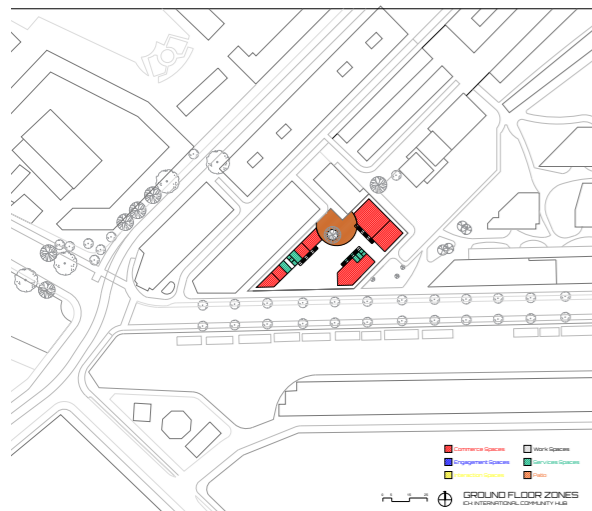
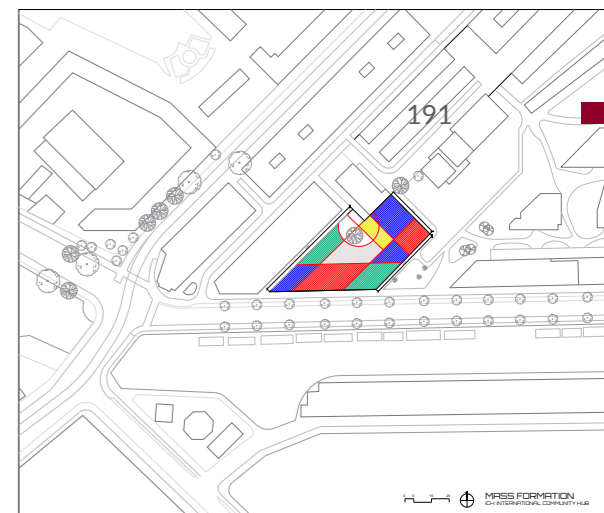
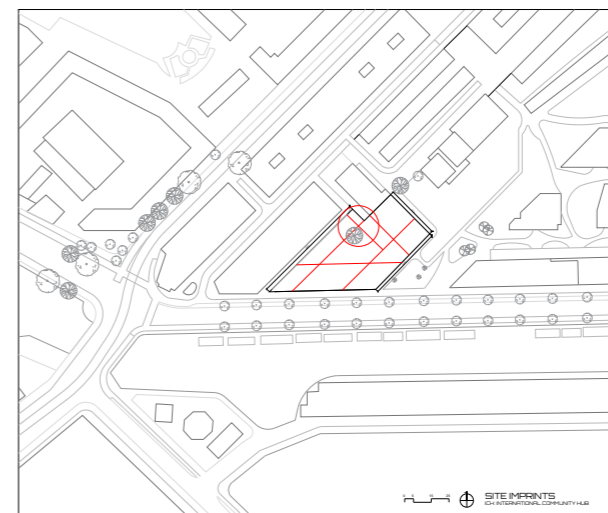
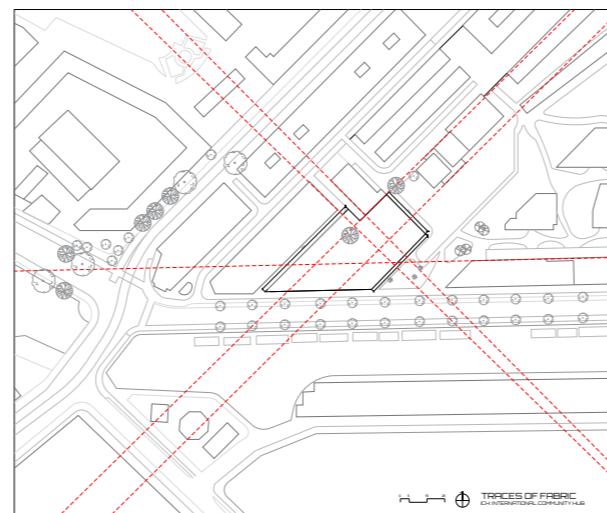
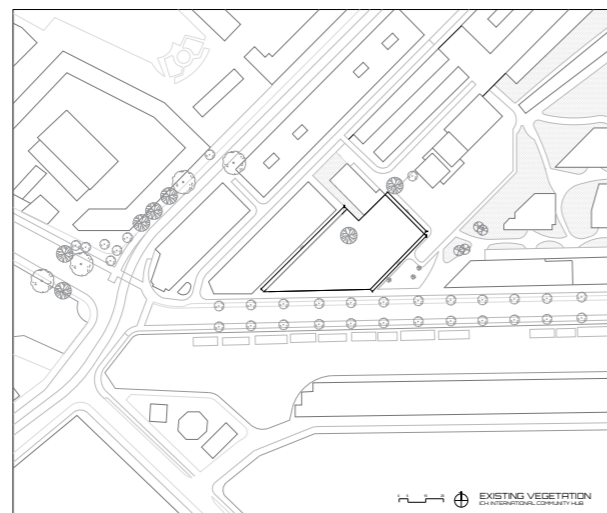
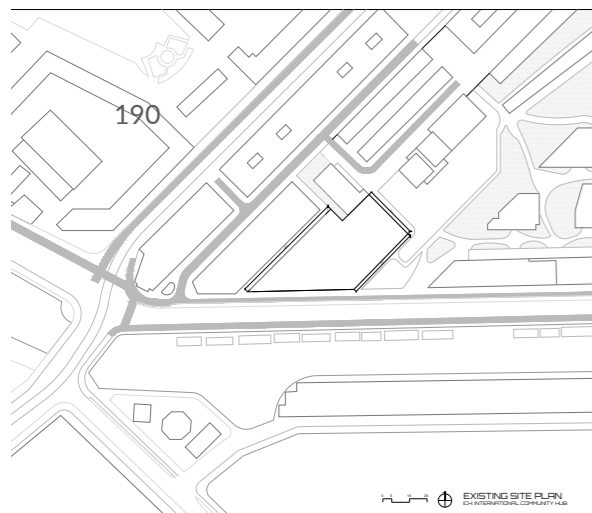

ICH LAYERS

L0 (Solar Roof Layers, 4th Floor Roof)

- Attached dynamic photovoltaic solar panels from SunPower
- Geotextyle protection Layer
- 1 layer of synthetic protection layer
- 2 layers of bit. sheet waterproofing
- 2 layers of Bitumen patching compound + Rooting Barrier
- EPS inclination layer
- 15cm EPS Thermal Insulation + Shock Thermal Break
- 1 layer of Bitumenous vapor barrier
- 40cm monolithic post tensioned R.C.
- 3 mm smoothing + paint

L1 (Green Roof Layers on PT RC Slab, 3rd Floor Roof)

- Vegetation plantings
- Extensive Substrate
- Filtering Layer
- Drainage Layer
- Geotextyle protection Layer
- 1 layer of synthetic protection layer
- 2 layers of bit. sheet waterproofing
- 2 layers of Bitumen patching compound + Rooting Barrier
- EPS inclination layer
- 15cm EPS Thermal Insulation + Shock Thermal Break
- 1 layer of Bitumenous vapor barrier
- 40cm monolithic post tensioned R.C.
- 3 mm smoothing + paint

L2 (Green Roof Layers on Steel Slab, 3rd Floor Cantilevered Roof)

- 10 cm Landscaping gravel and vegetation extension from the RC slab
- Geotextyle Protection Layer
- 1 layer of synthetic protection layer
- 2 layers of bit. sheet waterproofing
- 1 layer of Bitumenous vapor barrier
- EPS inclination layer
- 2 layers of Bitumen patching compound + Rooting Barrier
- 1 cm Screed
- 12 cm RC Filling the Corrugated sheets' valleys
- 22 GA Corrugated Steel Sheet Topped with RC (12 cm)
- 36 cm I Section Steel Beams

L3 (Floor Layers on the PT RC Slab in 1st-, 2nd-, and 3rd- Floor)

- 9 cm Polished Concrete + Coating
- 1 layer of PE foil
- 2 cm mineral wool acoustic insulation
- 40 cm of Post Tensioned monolithic R.C. Slab
- 3mm smoothing+paint

L4 (Floor Layers on Steel Cantilevered Slab in 1st-, 2nd-, and 3rd- Floor)

- 4 cm Polished Concrete
- 1 cm Screed
- 12 cm RC Filling the Corrugated sheets' valleys
- 22 GA Corrugated Steel Sheet Topped with RC (12 cm)
- 36 cm I Section Steel Beams

L5 (Ground Floor Slab in the open, unheated Central Hub)

- 1 layer polyurethane deck coating
- 5 cm screed
- 1 layer PE folia protecting layer
- 40 cm of Post Tensioned RC Slab
- 1 layer plastic waterproofing
- 20 cm RC screed/hardcore
- 80 cm Pile Caps (Radius 110 cm)
- Soil

L6 (Ground Floor Slab in the heated islands)

- 9 cm of polished concrete + Coating
- 5 cm screed
- 1 layer PE folia protecting layer
- 40 cm of Post Tensioned RC Slab
- 20 cm compressed mineral wool insulation
- 1 layer plastic waterproofing
- 20 cm RC screed/hardcore
- 80 cm Pile Caps (Radius 110 cm)
- Soil

L7 (Monumental Stairs Layers)

- 2 cm of Recycled Dutch Elm Wood Finishing
- 1 layer of Wood Floor Adhesive
- 15.5 x 230 cm Prefabricated RC Stairs' Tread Units

Perimetrical Wall Layers (of the Coherence Masses' solid walls)

- 2 cm of Recycled Stabilized Aluminum Foam for the External Prefabricated Skin
- 5 cm Air Gap
- 20 cm Mineral Wool Thermal Insulation
- 20 cm cast in place inclined RC wall
- 6 cm of Recycled Thatch-Like interior finish

Perimetrical Wall Layers (The Folding Skin of the rest of ICH)

- 2 cm of Recycled Stabilized Aluminum Foam Panels for the External Prefabricated Skin attached on two top- and below- steel railings
- 200 cm Outdoor balcony
- 10 cm of Schock Thermal Break to cover the slabs and the cornices
- 10 cm of Air-Tight steel framed Low-E, Double Cardinal 272 coating, double argon, double super spacer, (Sound- and Thermal- Insulating Triple Glazing)

PARTICIPANTS IN THE CONSTRUCTION OF ICH

3

Architectural Designer
Delovan Delawer

Location
Amsterdam, Netherlands

Client

Középtanszék BME/Uni.xyz

Architectural Consultant

Dr. Schrammel Zoltán

Construction Technology and Management Consultant

Dr. Lepel Adrienn

Building Energetics and Plumbing Consultant

Dr. Zoltán Magyar

Mechanics, Materials and Structures Consultant

Dr. Hegyi Dezső

Building Construction Consultant

Dömötör Álmos

Local Dutch Opponent

Ommar & Rühl

Local Dutch Opponent

Local Dutch Opponent

Local Dutch Opponent

Local Dutch Opponent

Local Dutch Opponent

Local Dutch Opponent

Local Dutch Opponent

Local Dutch Opponent

Local Dutch Opponent

Local Dutch Opponent

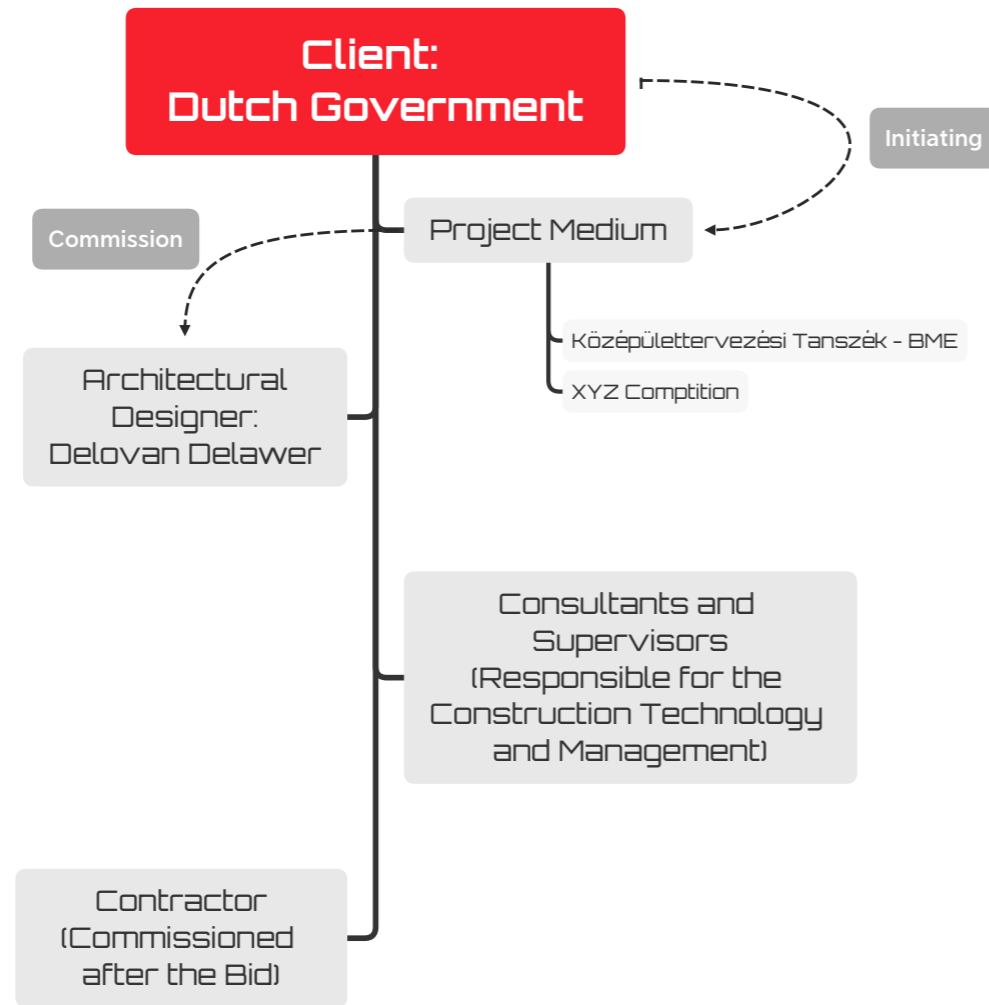

PM and Supervisors

To be Hired based on their

proposals of schedules and exposure to such projects

Contractor

Selected after a winning bid they submit

PUBLIC USERS OF ICH COMPLEX

All their categories are illustrated in the figures on the side

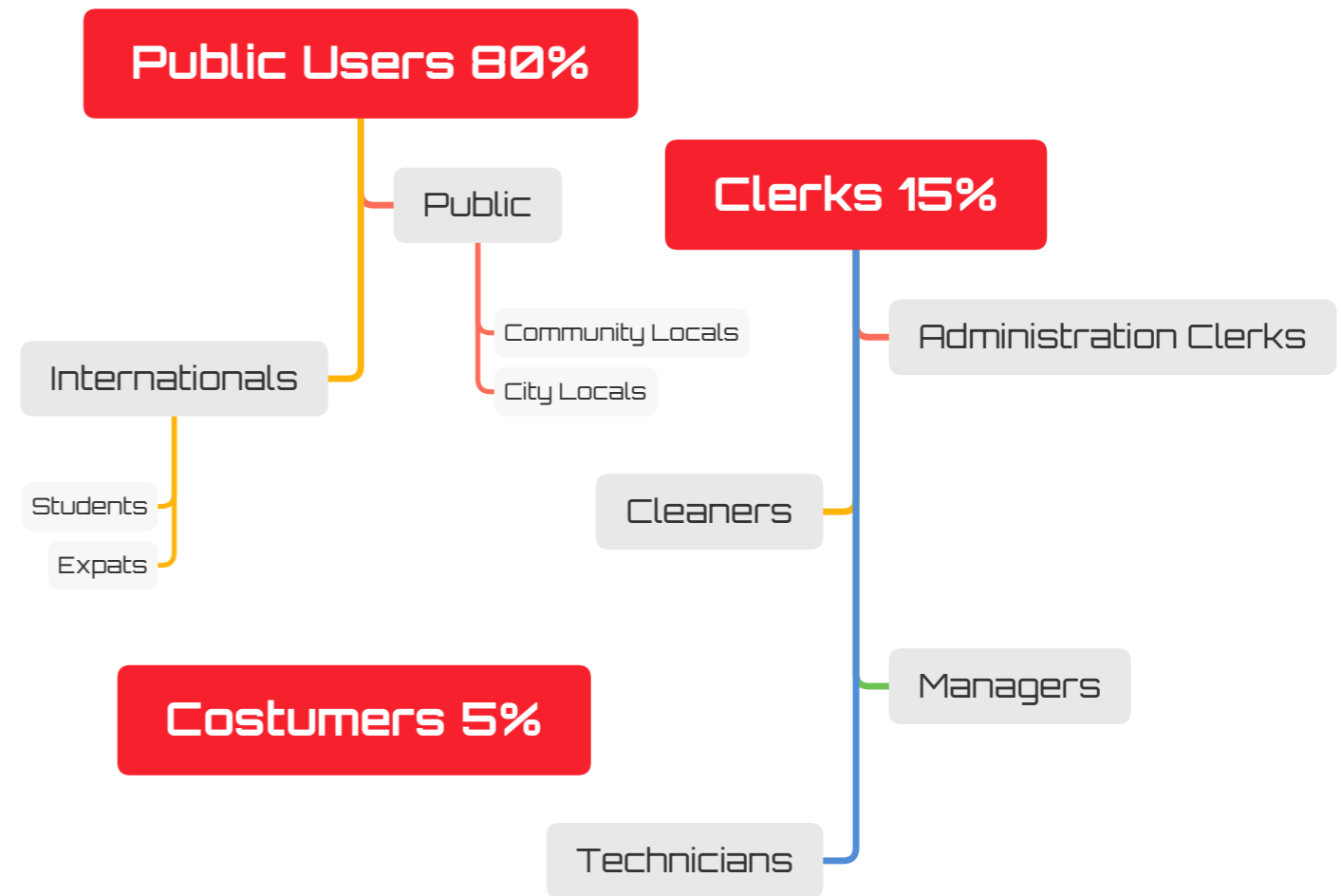

USER GROUPS OF THE ICH COMPLEX

1. Public Users:

Are those who may come to the building to enjoy the public facilities within the landscape, cafe and entertainment in the middle of Czaar Peterbuurt. They make up the majority of the user types, up to 80%. Off this percentage, up to 60% would be benefiting and bringing benefits to the commercial and social zones within ICH.

2. Clerks:

Those who actually run the building and the main functions of the building, residing in the

offices. Alongside the technicians that keep the building maintained. They make up to 15% of the user types. This category includes the officers at the control room and administrative offices. This category subcategorize into the Office Clerks, Technicians, Cleaners, Managers, and Janitors.

3. Customers:

This user group are those who put the community center and its specialty commercials into their use, they make up to 5% of the total user types count of the ICH complex.

GOALS OF CONSTRUCTION OF ICH COMPLEX 4

The building aims to achieve multiple goals among which political goals which are creating stronger International relations as the ICH would be like an international safehaven or global embassy, name it whatsoever, as the project aims to create a second home to integrate for the international students and the expats. The project does also aim to attract more users to this local dominated area of the variant city of Amsterdam, there comes the economic goal, which is actually one of the main goals, since the building offers services to the public which is around 80% of the people visiting the site, and also the 15% of the users that are employees which means it is providing their families a living. One of the main targetted user groups of ICH Complex is the customers, discussed in the second part of the previous chapter in the user types.

The operational time and working hours are as following:

8:00 AM - 6:00 PM working hours and the building is open (indoor)

7:00 PM - 11:59 PM the landscape of the building will be open to the public as a public space or/ park, and becomes just another plot of the Funnenpark.

SCHEDULE OF CONSTRUCTION OF ICH COMPLEX 6

The schedule of the ICH Complex is to be set into two main phases that is broken down in Annex D, the Gantt Chart, the two main stages are composed: Phase One, which is the Planning Phase of which, the preparation for, must begin on January 1, 2021, and that in turn breaks down into two sub-categories, a) Research Phase, and b) Design Development. In which both sub-phases would take around around a year and a half. The second phase would be the Contracting and Construction which must start at the end of the first phases which ends in August 8 2022, which would last at least a good 450 days. So its fair to say that the schedule consists of two main milestones having to start with the planning phase and getting the necessary funds, so the construction could start which marks the second milestone of the project until the skeleton frame is erected which in turn allows other activities to be started, the second milestone fades as the construction process comes to an end. The factors that could affect the time estimation the most is just as any other project, the comitment of the contractors and supervisors within the construction phase, through transporting the materials to the site and carrying out other activities could be said to be the most challenging aspect in the time estimation, let alone the weather conditions and other typical project delaying factors, that must be taken into account

Please revise Annex D, for the detailed time schedule.

COSTS OF THE WHOLE CONSTRUCTION PROJECT 5

The ICH Complex overall construction cost is to be estimated around 31,262,330 Euros (which equivalent to 9,378,699,000 HUF). The 2500 sqm plot in Czaar Peterbuurt which is roughly estimated to be worth of 15,000,000 Euros which would be provided by the Ministry of Planning in The Netherlands (Dutch Government).

Although the cost of construction is mostly dependent on the quality of the materials used for the construction and their originating location, and as discussed before, for the project to succeed it is better to consume locally available materials and assign local experienced labor. The Structure of the project, on the other side, the skeleton frame and structural shering walls would form the highest concern in the cost estimation process. Not to mention that the preparation period would not cost a lot of money, since it was a competition held by BME. Therefore, there are not a lot of cost measures to be taken into consideration in an extra manner.

Please refer to Annex C for a broken-down data of the cost.

CIRCUMSTANCES OF THE CONSTRUCTION PROJECT 7

As the project was through a held competition (which is the way how most of big projects are done in the Netherlands) the whole process was very clear at most of the times, and the guidance of the consultants and people in charge was mostly technical and precised.

To speak of the site circumstances, the area is 2500 sqm, it has a setback of 2 meters, with coordinates of 52°22'03.9"N 4°55'39.2"E, and Maximum Ground coverage of 100%, Maximum Height of 24 meters, and a Built Up Area of 4600 sqm. With the high amount of other regulations set by the city council of Amsterdam, there is a huge flexibility set by the council for the sake of better architecture in the city, as the regulations, legislations and other building codes could be completely overwritten for any project if it had good reasoning and good architectural solutions. So the rules are there to break to phrase it propoerly. On the other hand, there could be one problem which the project might face, that is the unreasonable delays in schedule that might happen because of delayed paperwork or lag in the funding procedure, which could basically happen due to the global economic crisis because of the COVID-19 pandemic, leaving most of projects on pause for an unknown notice. Other than that, most conditions seem ideal and coherent to build with.

TECHNICAL INFORMATION OF ICH COMPLEX

8

The 2500 sqm site of the ICH Complex planned in Czaar Petersbuurt, in a vacant plot right beside the Funnenpark and it is to be constructed on the closest point of the approaching street to the site that is planned to be part of the park.

There is relatively a quiet street network around the site due to the residential park of

Funnenpark, though it is a great potential to create this integral community center to meeting variant young innovatives and talents. The problem with this street network is not that it is a quiet one, but actually it is a narrow one, although it could be pointed out as a weakness due to the hassle it brings to mobilization, the site of ICH itself could be very easily accessed since it will sit on the edge of the park, where there is plenty of complete openness and space, although it will have a fence during the process of construction, but the huge plane around it, clean off any built structures, will be in turn an easements for all the construction activities to be clearly and comfortably laid out on the site, from the bench marking Total Station to the bench marks of the to-be-built structures, offices for the PM, staff rooms, and their waterclosets, the workshop and fabrication areas to even the machinery parking (the transportation trucks) and the gaurd room as well. The new structures' infrastructure must be added and connected to those of the surrounding sites of the project, from a main drinking water supply line branch, and sewage network, let alone the power lines, and telecommunication lines. That from the perspective of the construction management.

To discuss the technical information of the buildings themselves, the footprint of the new structure is erected up to 5 floors. The finishing is to be of futuristic steel sheets cladding over the insulated RC walls. To speak of the function of the project is to serve the ICH, and its community integral purposes, the design proposal is composed of two existing Hangars, that are to be renovated and remodeled, and adding two masses to serve the purposes of entertainment, relaxation, and administration to the visitors and the project's

and/or site's users. The Activities of entertainment and relaxation is housed by spaces of restaurants, cafes, small pools, sauna, showers, changing rooms, resting area, congregation areas, lobbies offices, workshops, lecture halls and storages.

All the details of the finishings as well are added in a table to Annex E along with the site plan and other drawings of the project.

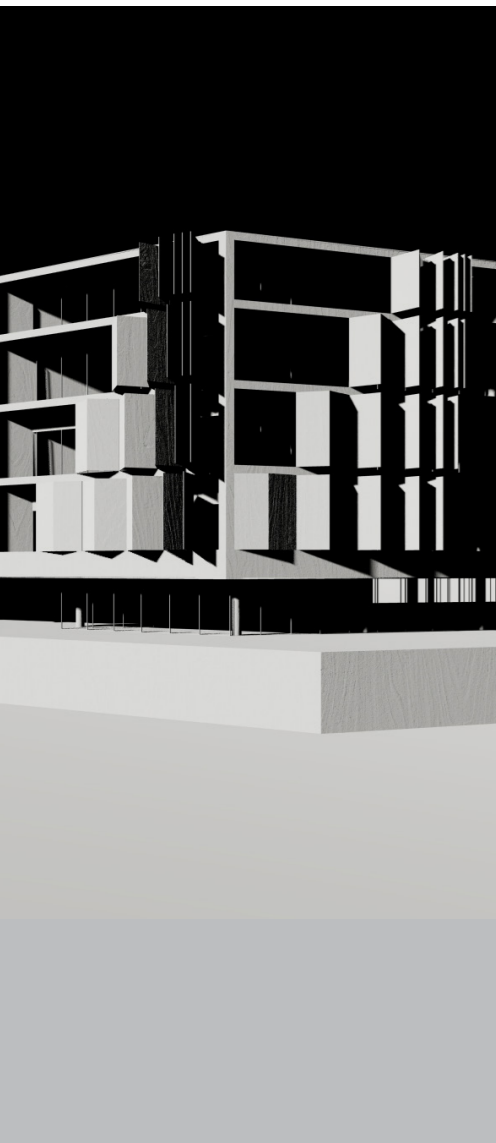

FINISHING MATERIAL LIST

1. Steel Sheets over the insulated RC walls for the exterior finishing
2. Recycled Thatch Looking Interior Finishing
3. Green Roof + SunPower Photovoltaic Solar Panels
4. Double railed folding/dynamic steel skin articulating the Breeze Out.
5. The curtain wall behind the folding steel sheets is composed: Double Cardinal 272 coating, double argon, double super spacer, steel framed smart glass of 10 cm width (Sound- and Thermal- Insulating Triple Glazing)



CREATE PM OFFICE

Create an office for the PM on construction site.



NEIGHBORING FACILITIES

Integrate the existing urban infrastructure into the introduced community center.



ON-SITE WORKSHOP

Create on-site construction and fabrication workshop area.



STAFF ROOMS

Having staff rooms, dedicated Waterclosets and a gaurd room on construction site.



MACHINERY PARKING

Having on-construction-site parking for the construction machinery and vehicles.



THE THREE ENTRANCES

Educational, Social, and Coherence entrances or ground masses are to be used for temporary storages during construction period.

ANNEX A MINDMAP OF ICH

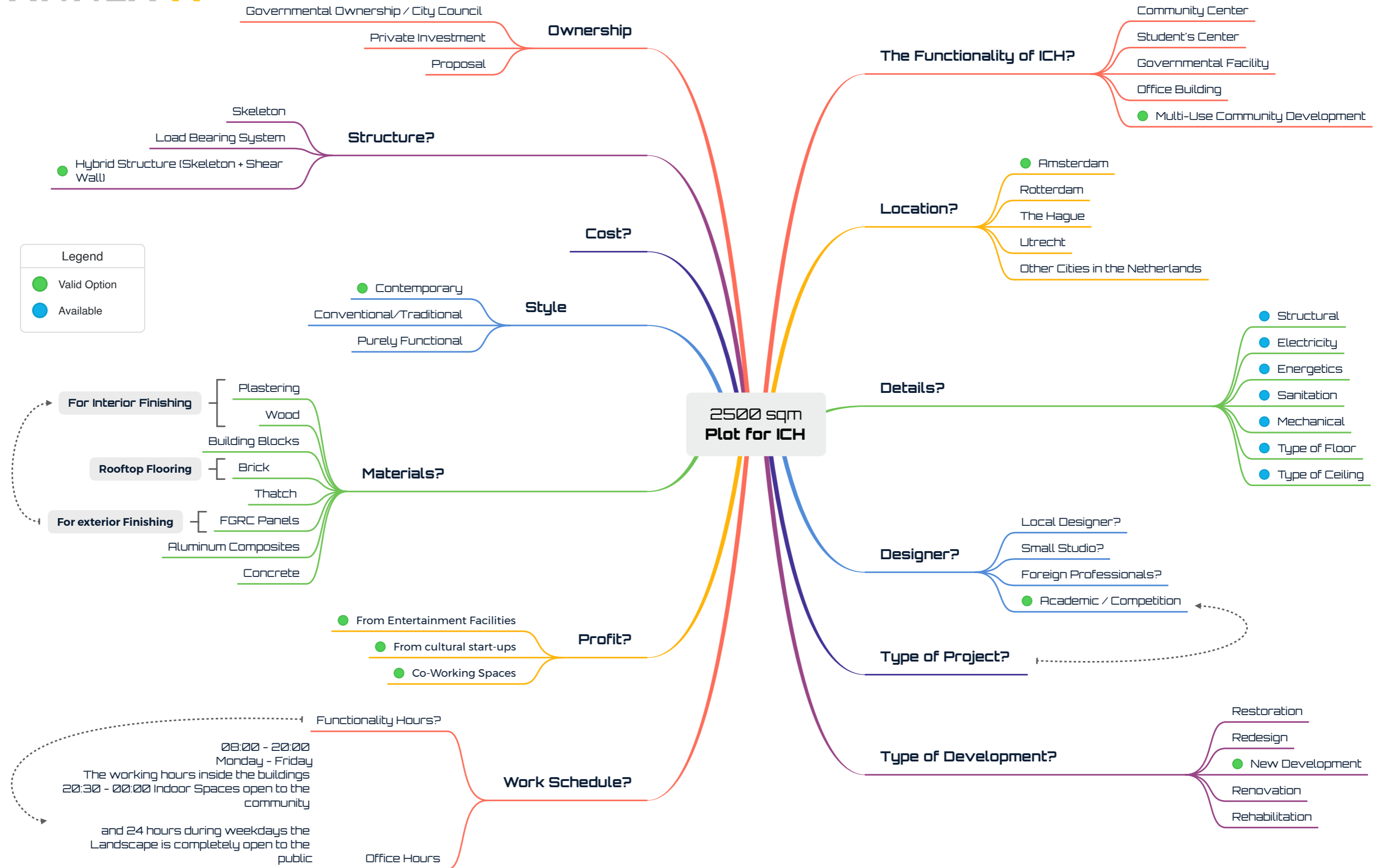

ANNEX B FUNCTIONAL SCHEMA

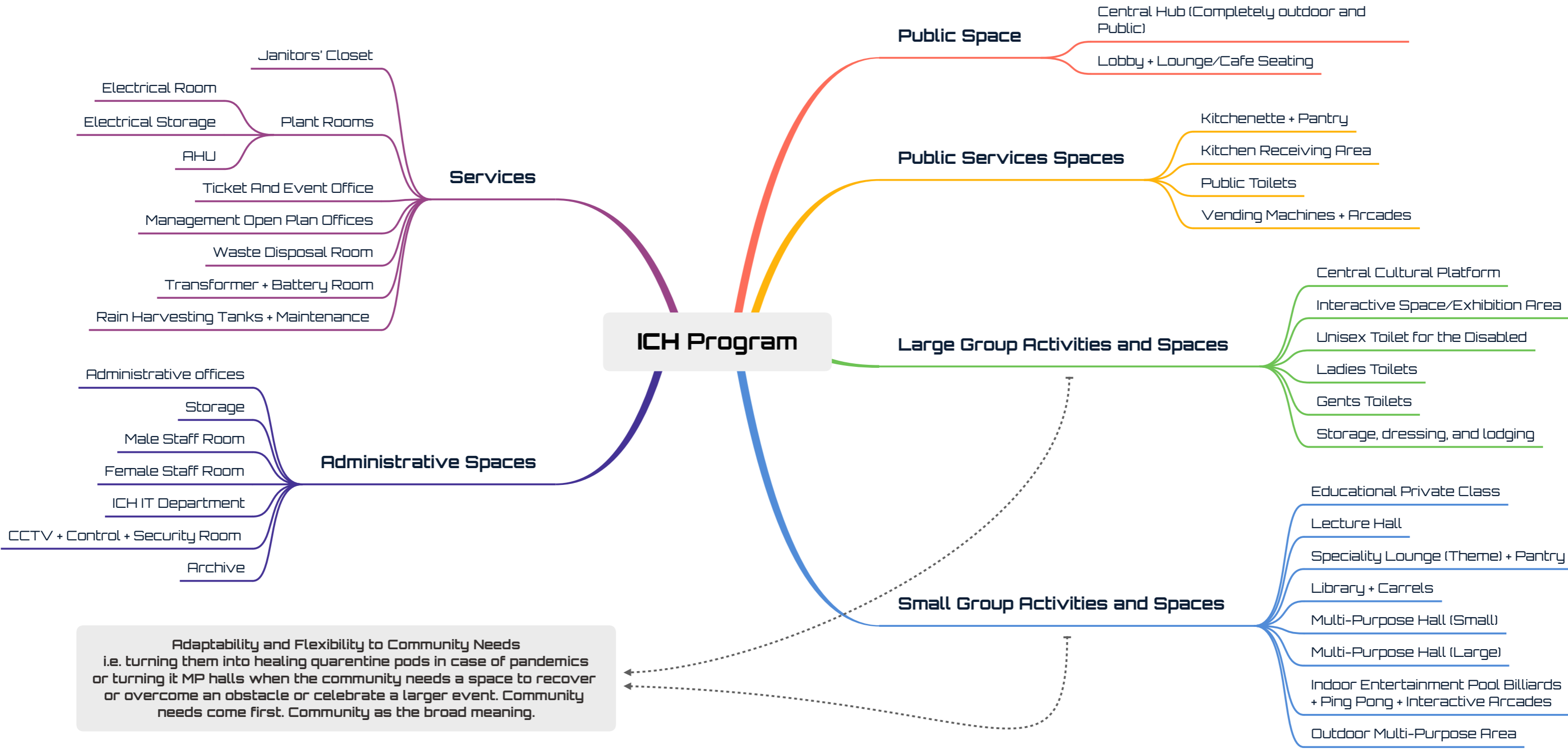

ANNEX B FUNCTIONAL SCHEMA

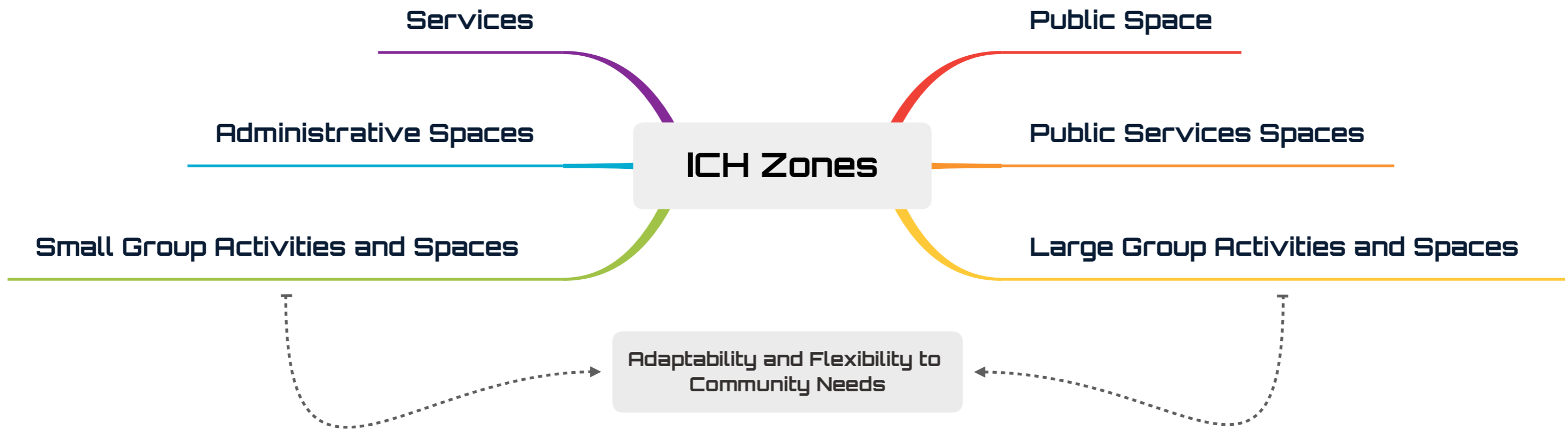

ANNEX C COST ESTIMATION

279%

INVESTMENT COST

No	COST GROUP	ESTIMATE COST (EUR)	ESTIMATED PERCENTAGE
100	PLOT	€ 15,000,000.00	134%
200	INFRASTRUCTURE	€ 1,121,540.00	10%
300	BUILDING CONSTRUCTION	€ 11,215,400.00	100%
400	BUILDING INSTALLATIONS (POWER + SANITATION)	€ 1,121,540.00	10%
500	OUTDOOR CONSTRUCTION (LANDSCAPING)	€ 1,121,540.00	10%
600	INSTALLATIONS AND FURNISHING	€ 1,121,540.00	10%
700	ADDITIONAL EXPENSES	€ 1,682,310.00	15%
TOTAL AMOUNT		€ 31,262,330.00	279%

Land value of the plot is exactly between 5774-6416 euros per sqm, so **6000 euros per sqm** was chosen. Assuming 872.3 Euros is the unit price for 1 sqm

FLOOR	GF	FF	SF	TF	4F	TOTAL
AREA	1200	2000	1875	1105	680	6860

FLOOR	GF	FF	SF	TF	4F	TOTAL
VOLUME	5760	9600	9000	5304	2380	32044

UNIT PRICE PER CUM FOR CONSTRUCTION EST.	€ 350.00
--	-----------------

BUILDING CONSTRUCTION + INSTALLATIONS COST

No	COST GROUP	ESTIMATE COST (EUR)	ESTIMATED PERCENTAGE
300	BUILDING CONSTRUCTION	€ 8,972,320.00	80%
400	BUILDING INSTALLATIONS (POWER + SANITATION)	€ 2,243,080.00	20%
TOTAL AMOUNT		€ 11,215,400.00	100%

100%

GROUP 300 COST BREAKDOWN

No	COST GROUP	ESTIMATE COST (EUR)	ESTIMATED PERCENTAGE
310	EARTHWORK	€ 336,462.00	3%
320	FOUNDATION	€ 1,570,156.00	14%
330	EXTERNAL WALLS	€ 1,906,618.00	17%
340	INTERIOR WALLS	€ 560,770.00	5%
350	ROOF	€ 785,078.00	7%
360	FLOOR (SLABS)	€ 2,691,696.00	24%
370	BUILT-IN APPLIANCES	€ 672,924.00	6%
380	OTHER	€ 448,616.00	4%
TOTAL AMOUNT		€ 8,972,320.00	80%

80%

300	BUILDING CONSTRUCTION	€ 8,972,320.00	80%
400	BUILDING INSTALLATIONS (POWER + SANITATION)	€ 2,243,080.00	20%
TOTAL AMOUNT		€ 11,215,400.00	100%

GROUP 400 COST BREAKDOWN

No	COST GROUP	ESTIMATE COST (EUR)	ESTIMATED PERCENTAGE
410	WATER, SEWAGE, GAS	€ 336,462.00	3%
420	HVAC	€ 336,462.00	3%
430	ELECTRICITY	€ 224,308.00	2%
440	TELECOMMUNICATION AND INFORMATION TECHNOLOGY	€ 336,462.00	3%
450	TRANSPORTATION EQUIPMENT	€ 224,308.00	2%
460	TECHNOLOGY EQUIPMENT	€ 336,462.00	3%
470	INTEGRATED BUILDING- AND SERVICE- MANAGEMENT	€ 336,462.00	3%
480	OTHER	€ 112,154.00	1%
TOTAL AMOUNT		€ 2,243,080.00	20%

20%

300	BUILDING CONSTRUCTION	€ 8,972,320.00	80%
400	BUILDING INSTALLATIONS (POWER + SANITATION)	€ 2,243,080.00	20%
TOTAL AMOUNT		€ 11,215,400.00	100%

ANNEX D SCHEDULE OF CONSTRUCTION

NETWORK METHOD

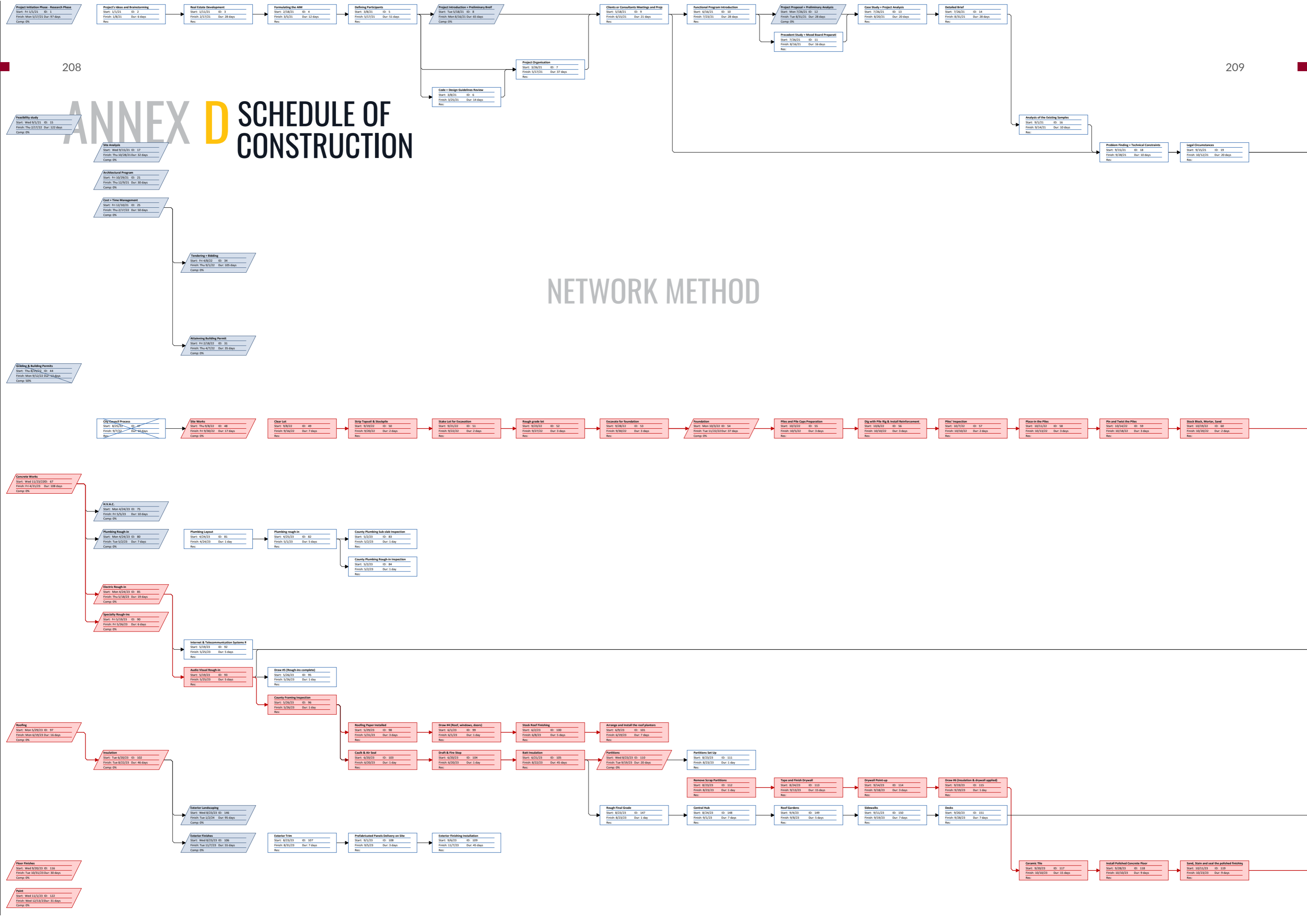

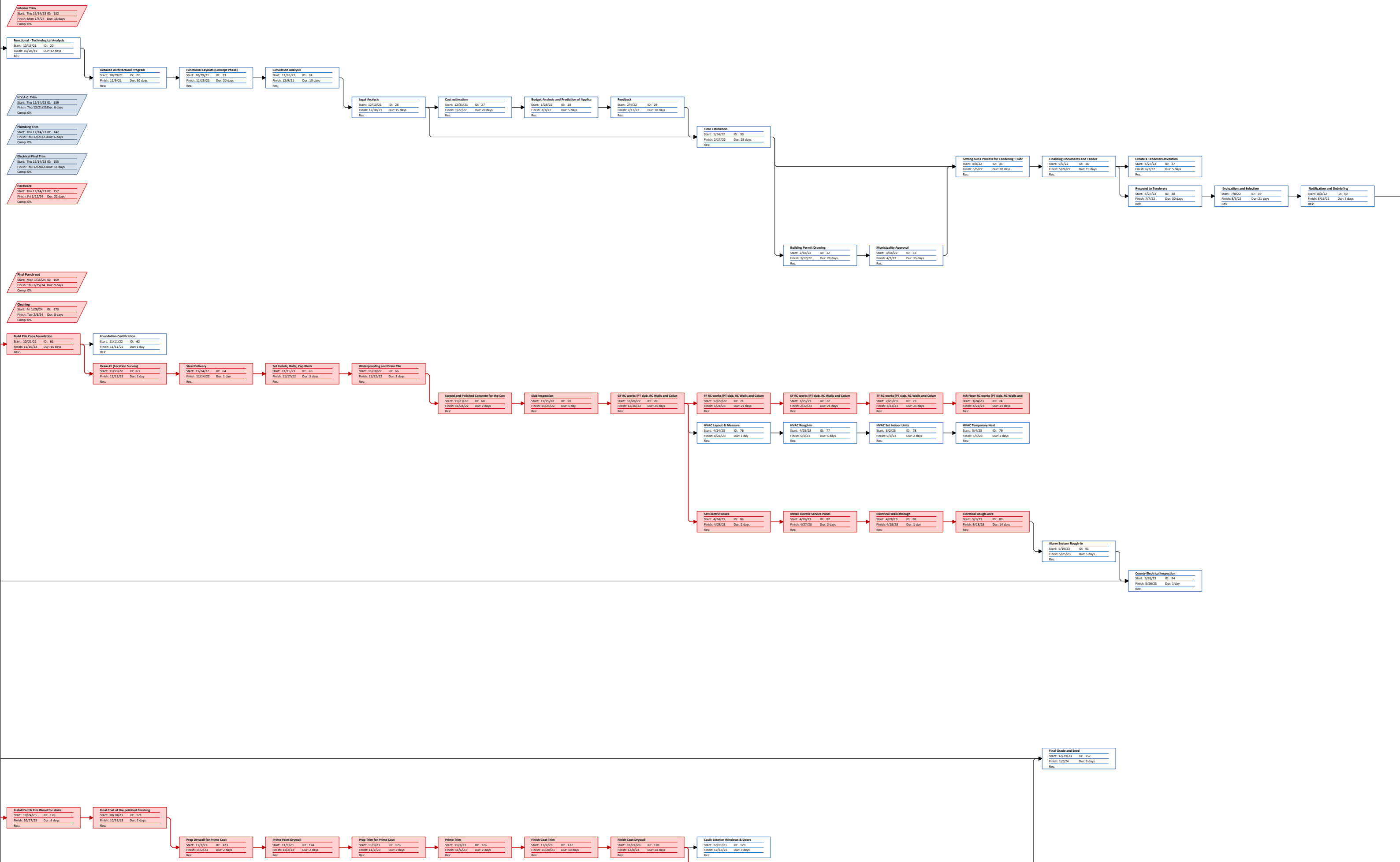

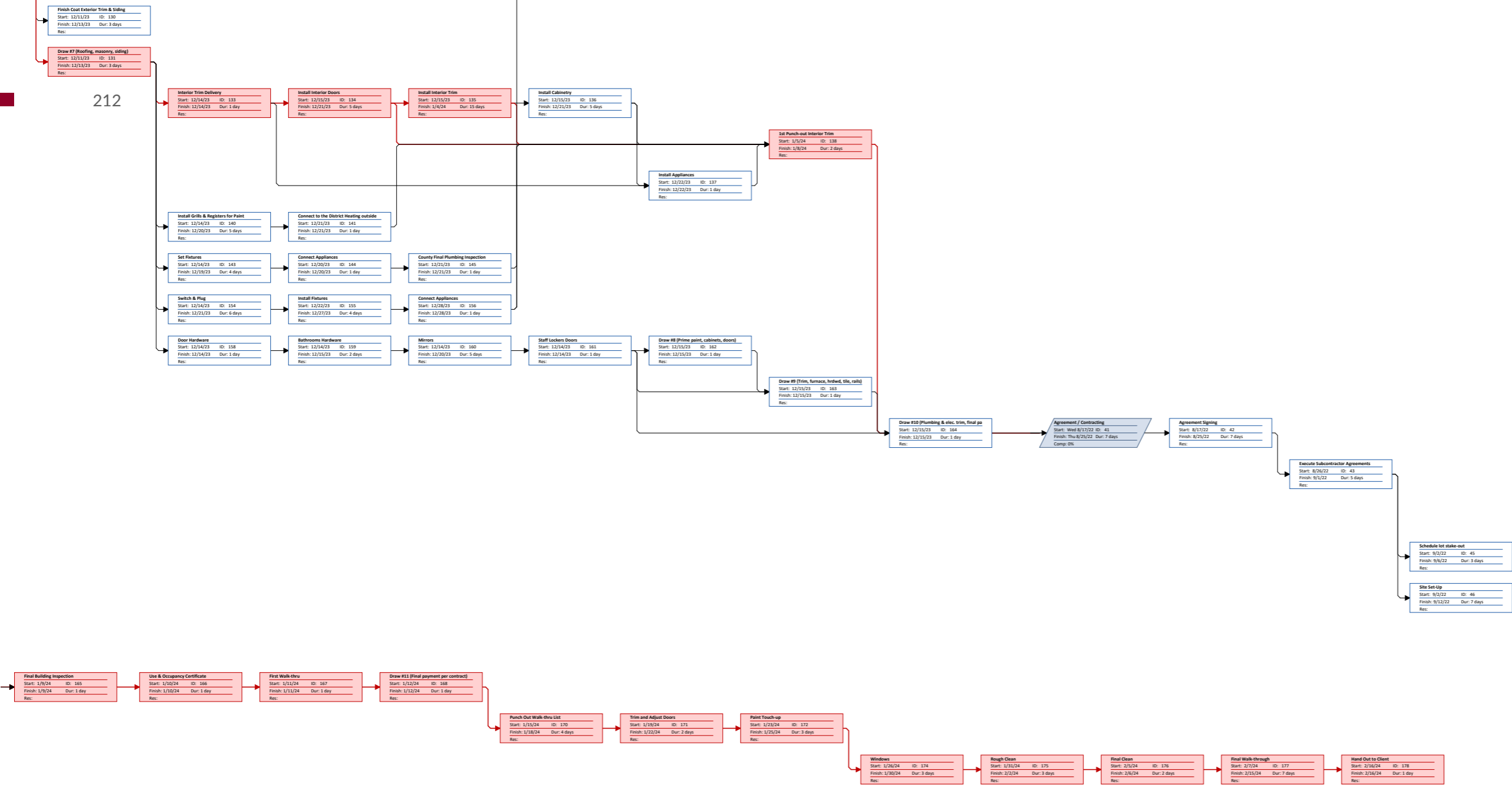

SCHEMATIC TIMELINE OF THE MAIN ACTIVITIES

(THE DETAILED TIMELINE IS ILLUSTRATED IN THE NEXT PAGE)

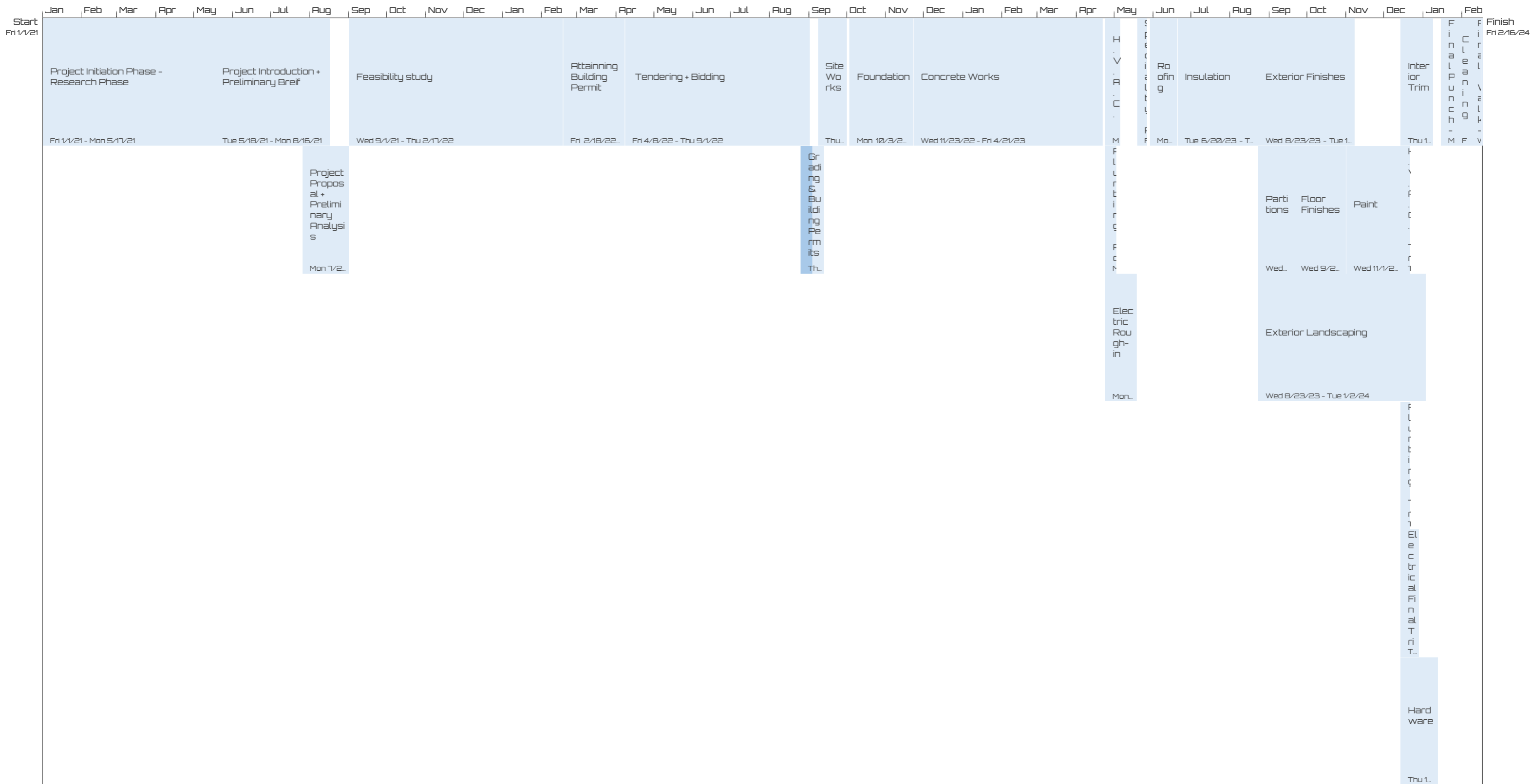

DETAILED TIMELINE OF THE ACTIVITIES

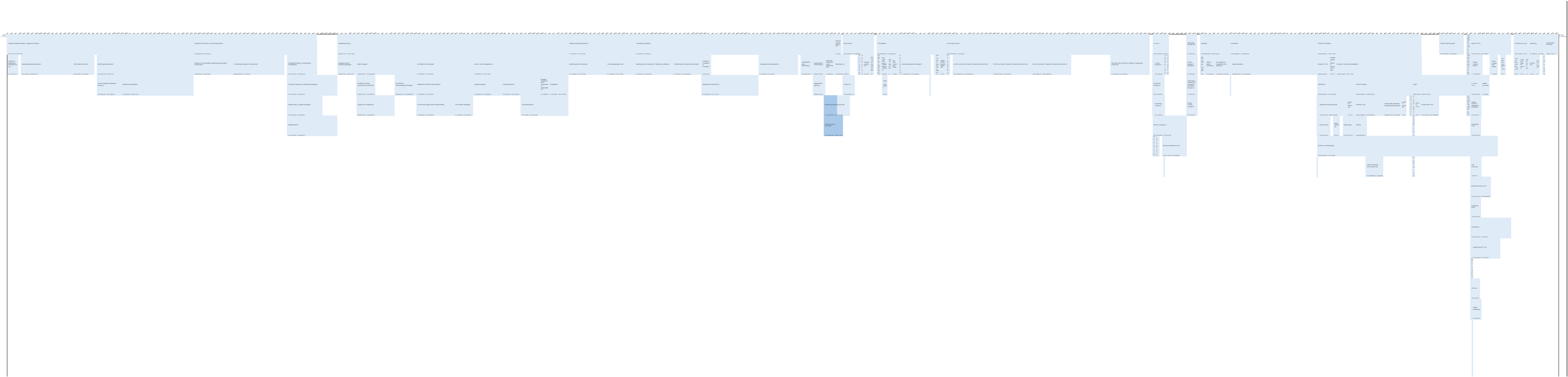

ANNEX E CONSTRUCTION TECHNOLOGY THE ACTIVITIES' DESCRIPTION

Site Work

Setting up the site, by initially cleaning it through, following the initial CM drawing in which the gate and entries are pointed out along side the fence, on which it sits on few parts of the funnenpark and taking almost the whole sidewalk on the street, temporarily for the construction period. The debris collected from the site cleaning hence are headed out for recycling. And also the Top soil that is stripped could be very valuable, so part of it that would be used for ICH itself will be stored for later, and the rest is sent with the debris for the recycling plant in Amsterdam. Following the site set up, temporary structures are set up such as the staff rooms, guard room, toilets and storages are to be built. And then set up the benchmarking stations for the surveying points and excavation could start for the foundation. *Please review the Construction Technology and Management Drawings for more information*

ICH Foundation

Pile Rigs are the first intruder in the process of digging for the foundation. The process for the deep foundation of the RC Piles will follow the Continuous Flight Auger technology in which a methodology takes place firstly by a continuous drilling with the pile rig until the designated depth is reached, the depth is determined by the use of a guiding tube. After the digging is over, pouring concrete into the pile holes begin, and the drills are removed. Then the steel reinforcement is vibrated in-place to hold their proper position. The CFA technology for the deep foundation comes to an end after this step.

Then the Pile Caps come in place to sit on top of the the piles to form the hollow foundation, where the Central Hub and the ground level floor slabs settle. *Please review the Structural Drawings for more information, and Annex F's Conclusions for the equipments used.*

ICH Frame + Structure

After the foundation is set ready, and the cranes are in place, the structure starts to be assembled and built on site. Building up from the assembly of the precasted RC columns and central shear walls, a decision that was made to precast them because there is quite a number of a replicated modules. A steel formwork is also assembled on site for the cast-in place RC western wall of the building and the reinforced post-tensioned slabs of the floors. The 40 cm RC slabs have tensile steel cables pulling the slabs up from within, anchored at the ends of the slabs reinforcement (at the ends of the axes where the slabs end, *please review the Structural Drawings for more information*) This casting and assembly procedure of the concrete works repeat itself going up floor after another.

The Ground level slabs contain heated islands that are surrounded by thermal breaks since not the whole ground level is heated, as 50% of the site is completely open to the public, not the whole slab is thermally isolated, a decision that also has budget and duration returns. Although the whole slab has water proofing wrapping it from the gravelled layer. Same scenario applies to the columns, the ones inside are heated, unlike the ones outside that are wrapped with finishing only. then comes the first floor slab, which is completely

heat insulated which is wrapped with a 20 cm of Mineral Wool thermal insulation, the a 2 cm Stabilized Aluminum Foam panels finishing, that are separated by a 5 cm of an Air Gap. The same layering applies to the inclined Prefabricated RC wall on the western end of building. Hence the whole structure is explained what is left of the frame is the Monumental stairs that are made of prefabricated RC parts assembled and placed onto the 40 cm RC shear walls. The structural and frame works wrap up with the last floors' slab being built, as it would be wrapped with a waterproofing layer and thermal insulation again, as the same for the rest of the building, the whole structure is wrapped with 20 cm of Mineral Wool thermal insulation. *Please review the Building Construction Drawings for more information, and Annex F's Conclusions for the equipments used.*

Rough Ins

After the building structure is settled and everything is in place, from columns, beams, to slabs. The rough-ins take the next turn, First thing the HVAC system is connected to the District Heating/Cooling Plant of Amsterdam through a District Heating Unit and a Heat Exchanger, that will suffice ICH's needs with renewable and clean energy, which would be delivering Comfort Zone temperature to all spaces with a ducting network. This HVAC rough-in is done simultaneously with that of Plumbing and Electric/Power systems rough-in. They would hang from the ceiling with maximum height of 60 cm below each slab. *Please review the Building Construction Drawings for more information, and Annex F's Conclusions for the equipments used.*

Exterior Finishes

The exterior skin is composed of 100% Recycled Stabilized Aluminum Foam, that gives the same rough look as the thatch-like interiors of ICH, the skin is not just fully recycled but also 100% recyclable in case of any future alternation for maintenance reasons. These panels compose the whole facade, then comes what is beneath the skin, which is transparent curtain walls of the marvelous super efficient glass which has an incredible U Value of 0.13, it is composed of Double Cardinal 272 coating, double argon, double super spacers, with an air-tight steel frames making up the sound- and thermal- insulating triple glazing as efficient as a well-insulated wall. *Please review the Building Construction Drawings for more information, and Annex F's Conclusions for the equipments used.*

Interior Finishes

Through the time the exterior finishes are advancing and sealing off, the interior finishes start to be put together part-simultaneously. At the point after the rough-ins are all in place, the time has come finalize the interior spaces of ICH, it begins with setting up the partitions, where there are three types of partitions within ICH, a Double Layered Sound- and Thermal-Insulating Blocks of 20 cm construction used to separate spaces where sound insulation and heating requirement are unlike, a second type of a Double Layered Plaster- (Gypsum-) boards of 10 cm drywall construction used to separate spaces of the same acoustic and thermal requirements, and the third and last type of partitioning is a 10 cm of Smart Glass that goes completely solid, opaque, and transparent used based on the spaces program and requirements of ICH, it comes in two types, one fixed, the other is foldable and completely convertible to merge spaces and separate them based on need, this adds even more adaptivity than the smart glass specifications themselves, it is noteworthy that these glass panels are sound- and thermal- insulating.

Then floor and wall finishing come to place. The floor would be finished with Polished Concrete, to give a clean-cut look and yet very abstract not requiring a huge amount of labor or complex jointing, would be simply by a multi-step process where a the concrete floor is mechanically ground, honed and polished with bonded abrasives in order to cut a concrete floor's surface. The Finishing for the walls are two be either plastering/paint, or recycled thatch-like interior finishing in the bigger spaces, assembled panels of 6 cm, with manual labor, (mention doors) The stairs to be finished with Dutch Elm Wood collected from snag/dead trees, in the vicinity of Amsterdam, glued in-place. The RC shear walls around the monumental staircases are finished with planter's and a green wall. Regarding the glass partitions do have an insulating aluminum mullions and are fixed with steel joints to the concrete. After this, the following things are to be introduced are the light fixtures, ledges, machines, plumbing installations, mirrors, security frameworks, door handles, bathroom hardware, bars and railings, and ofcourse the reception desks and other built in furnitures. *Please review the Building Consturction Drawings for more information, and Annex F's Conclusions for the equipments used.*

Landscaping

The landscaping of ICH starts immediately after the rough-ins are in place, it starts from the Central Hub at the ground level, and also the roof top, the process includes planting moss in the Central hub, and greenery planting at the roof top, decks and walkways.

Since this is one of the last activities of the construction process of ICH, it was decided to keep the electrical final trim at the end of this activity, in terms there is a need to power landscaping lighting elements. *Please review the Annex F's Conclusions for the equipments used.*

Completion

Now that everything is almost finished, a final punchout is necessary, this is done with walk-through list to check all items, and trim all installations, paint touch-ups and fenestration adjustment would be the very final cuts. Before a final walk-through, the check list is completed and approved at every point, and the project is completely cleaned, delivering it to the Dutch Government is what is left. and Boom, everything is done. The community of Czaar Peterbuurt and Internationals can finally enjoy their neighborhoods new building, the ICH.

ANNEX F TECHNOLOGIES, EQUIPMENT, AND TOOLS USED.

In the construction of ICH, there are a few gear and instruments that are utilized for the development procedure, just like other similar projects. Within this annex, every possible instrument used in the construction process of ICH is to be mentioned and illustrated.

So to start with it, basically, the term ,apparatuses' alludes to instruments that are utilized by hand and the Hardware by and large alludes to a lot of devices utilized for a solitary reason. littler scale, there might be some cover between what is viewed as a plant, little plant, apparatuses, little devices, light gear or Hardware. ,plant' for the most part alludes to overwhelming Hardware.

Equipment and Hardware are significant in the development procedure. They are basically used to combine things or build up stuff such as (e.g., hammers and pneumatic nailers) or to

demolish or detonate them (e.g., jackhammers and saws). The equipment can be characterized for the most part as hand devices and power devices. what's more, every one of them casts a certain hazard.

Power devices are arranged into certain gatherings relying upon the Power Source that they get, for example, electrical equipment (controlled by power), pneumatic devices (fueled by compacted air), fluid fuel instruments (generally fueled by gas), powder-impelled devices (normally controlled by a hazardous and worked like a firearm) and water powered devices (fueled by pressure from a fluid).

This chapter tries to illustrate most of the instruments but in a scale order, smallest in size to the largest. In the conclusion, it is illustrated how they're used in the construction of ICH.

A- SAFETY AND SECURITY TOOLS

Hard Hat

These are utilized for the security and they are obligatory instruments in PPEs being drilled according to the worldwide development industry wellbeing gauges. By Wearing cap it shields representatives head from wounds.

Security Goggles

This device is additionally utilized in the building locales by the representatives for their Eye insurance; laborers eyes are presented to a small amount of metal articles and sharp rebar edges and it isn't insightful to go to the site without wearing wellbeing glasses.

Construction Boots

It maintains a strategic distance from the immediate contact with perilous material or machinery.

Safety Belt

Should be worn at the time doing work at the very stature.

Gloves

There are numerous sorts of gloves, the fundamental motivation to have it is wellbeing and security safety measures. While working with conductive materials like steel

B- LAND SURVEYING TOOLS

Total Stations

It is an Electronic Tool that is used in modern surveying. The total station is an electronic version of The theodolite.

Measuring wheel

it is a tool for measuring distances the range for this device can be to 9999.99 m and can be read-out in cm. The tolerance is below 0.02%.

Automatic level

It is an instrument to take levels of any surface.

Tri-partite aluminium ruler

The aluminium ruler is used for accurate measuring in mm of the planeness of bare surfaces such as asphalt, concrete, gravel, floors of sports accommodations, the range is 1-20 m and the accuracy is 0.3 mm.

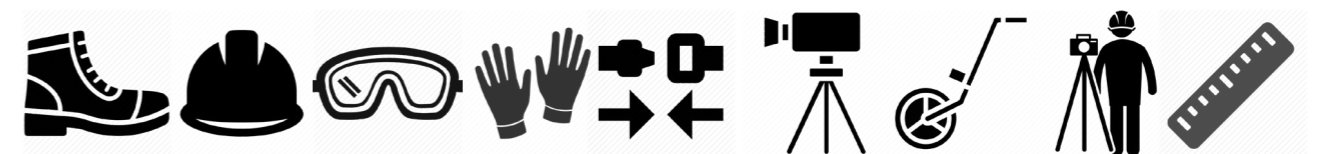

C- SMALL CONSTRUCTION TOOLS

Step Ladder

A step ladder is needed to reach those out of reach places safely.

Brick hammer

hammer is be used to remove of nailing in the bricks.

Screed

it is used for cutting the bumps in the concrete.

Circular saw

This tools is used for cutting wood, soft metal or even a plastic.

Chisel

It is used for cutting sharp edge or blade at the end with a holding grip.

Trowel

A trowel is a small hand operated shovel that is used for mixing the mortar in a steel bowl.

Tile cutter

Tile cutter is a cutter board that work by scratching a line on the tile and then by apply metal roller with pressure to cut the tile into two pieces.

Cordless drill

This machine is used either for drilling a small hole in some metal or wood and even for screw-driving operation.

Hand saw

Well it is a traditional blade / cutter used for cutting the wood panels or logs.

Screwdrivers

They are used for everything from putting together .

Measuring tape

It is a steel tape that is used as replacement of measuring chain in survey for measuring distance or lengths.

Power Drill

A power drill is different than the cordless drill since it has a cord. Having the constant power source attached to supply it, makes this drill have more power than the cordless drill. The power level doesn't waiver like that of a battery going dead.

Extension Cord

A standard house extension cord cannot handle a load of all of the power tools, though.

Laser Level

It measures the distance between itself and any chosen object.

Combination Pliers

Combination pliers have teeth to use when gripping an object, as well as a cutter for cutting wire.

Oscillating Multi-Tool

This tool can be used for Making all different types of cuts,Removing grout,Window repair, Wood floor installation, Preps wood for painting, Sanding, Drywall, cutouts, Caulk removal, Thinset removal, Angle Grinder.

Electrical Tester

Electrical testers check wires and outlets to see if they have live electricity running through them.

Soft Broom

The soft broom will be needed to clean the place up periodically.

Adjustable Wrench

Pick axe

Putty knife

Putty knife is a wide knife with a sharp edge and face made of metal 4" or 5" width. Putty knife is used for application of thin finishing putty on walls.

Spade

It is a digging tool that is used for manually excavating the soil.

D- MACHINERY

Vibratory compactors

Are frequently used machines to compact materials such as soil in order to increase its density for construction and are utilized for in landfill tasks.

Tower Crane

The tower crane is needed in the project because the building has a height of 24 meters. The Tower Cranes has some advantages which surpass the loading and lifting capacity of any other crane in the world, Their height capacity can't be matched by any other type of crane.

Piling Rig

A Piling Rig is used to drive piles into soil to provide foundation for buildings, bridges and other structures. A heavy weight is placed between guides allowing it to move up and down in a single line. Once places upon a pile, it is raised using diesel or hydraulics.

Concrete Mixer Trucks

In this project the standard Concrete mixer will be used that has a weight of 9,070 to 13,600 kg, and can carry roughly 18,100 kg of concrete, but the size of the mixers can be change from a vehivle to another one but The most common truck capacity is 6.1 cubic yards 6.1 m3.

Backhoe

also called rear actor or back actor is a type of excavating equipment, or digger, consisting of a digging bucket on the end of a two-part articulated arm.

Dump truck

Known also as a dumper truck or tipper truck, is used for taking dumps for construction as well as coal.in this project the Srandard dump truck. Dump truck configurations are 2, 3 and 4 axles. The largest of the standard European dump trucks is commonly called a "centipede" and has seven axles. The front axle is the steering axle, the rear two axles are powered, and the remaining four are lift axles.

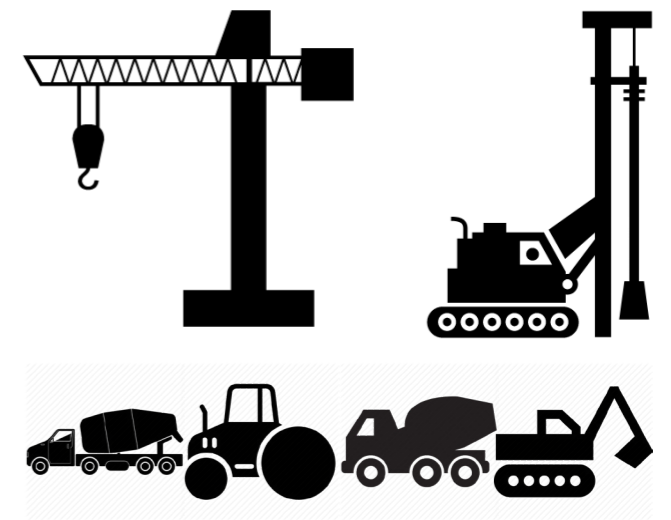

CONCLUSION OF ANNEX F: TECHNOLOGIES, EQUIPMENT, AND TOOLS USED

The tools are divided into several groups, Vibratory compactors and the backhoe will be used in the earthworks phase. The Piling Rig will be used in laying the pile deep foundation deep in the soil. The concrete mixer will be used in the load-bearing hollow foundation phases, the pile caps, or it might be needed in some small tasks after them. The crane will be fixed after the foundations are done. The dump truck will be used in the earthwork and foundation phase mainly but it might be needed in the following phases too. A Construction Lift/Elevator is also needed to transport materials vertically. The small tools are used in every phase of the project, the safety tools for the most phases.

ANNEX G CONSTRUCTION PHASE

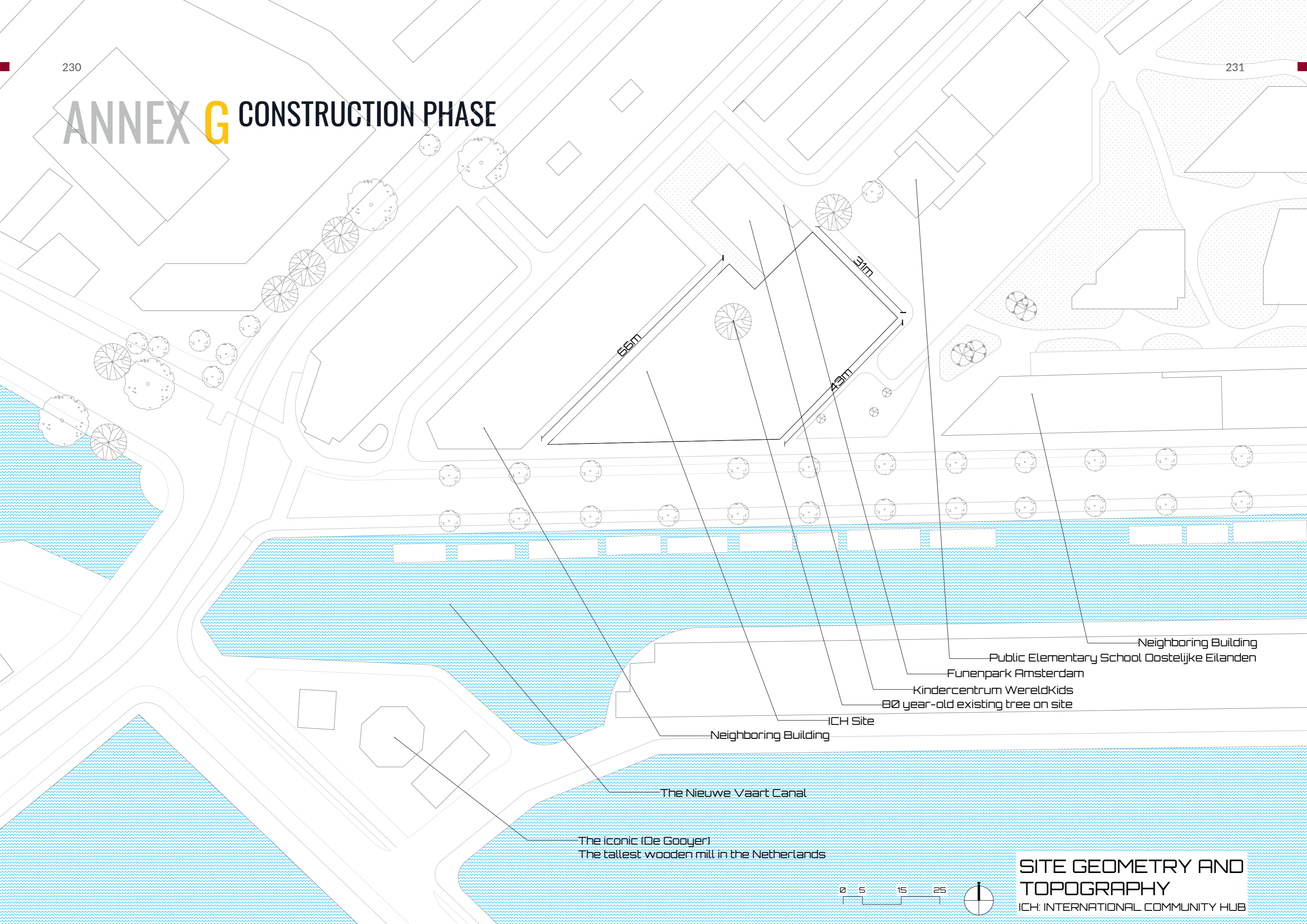

Neighboring Building

Public Elementary School Oostelijke Eilanden

Funenpark Amsterdam

Kindercentrum WereldKids

80 year-old existing tree on site

ICH Site

Neighboring Building

The Nieuwe Vaart Canal

The iconic (De Gooyer)
The tallest wooden mill in the Netherlands



SITE GEOMETRY AND TOPOGRAPHY
 ICH: INTERNATIONAL COMMUNITY HUB

ANNEX G CONSTRUCTION PHASE

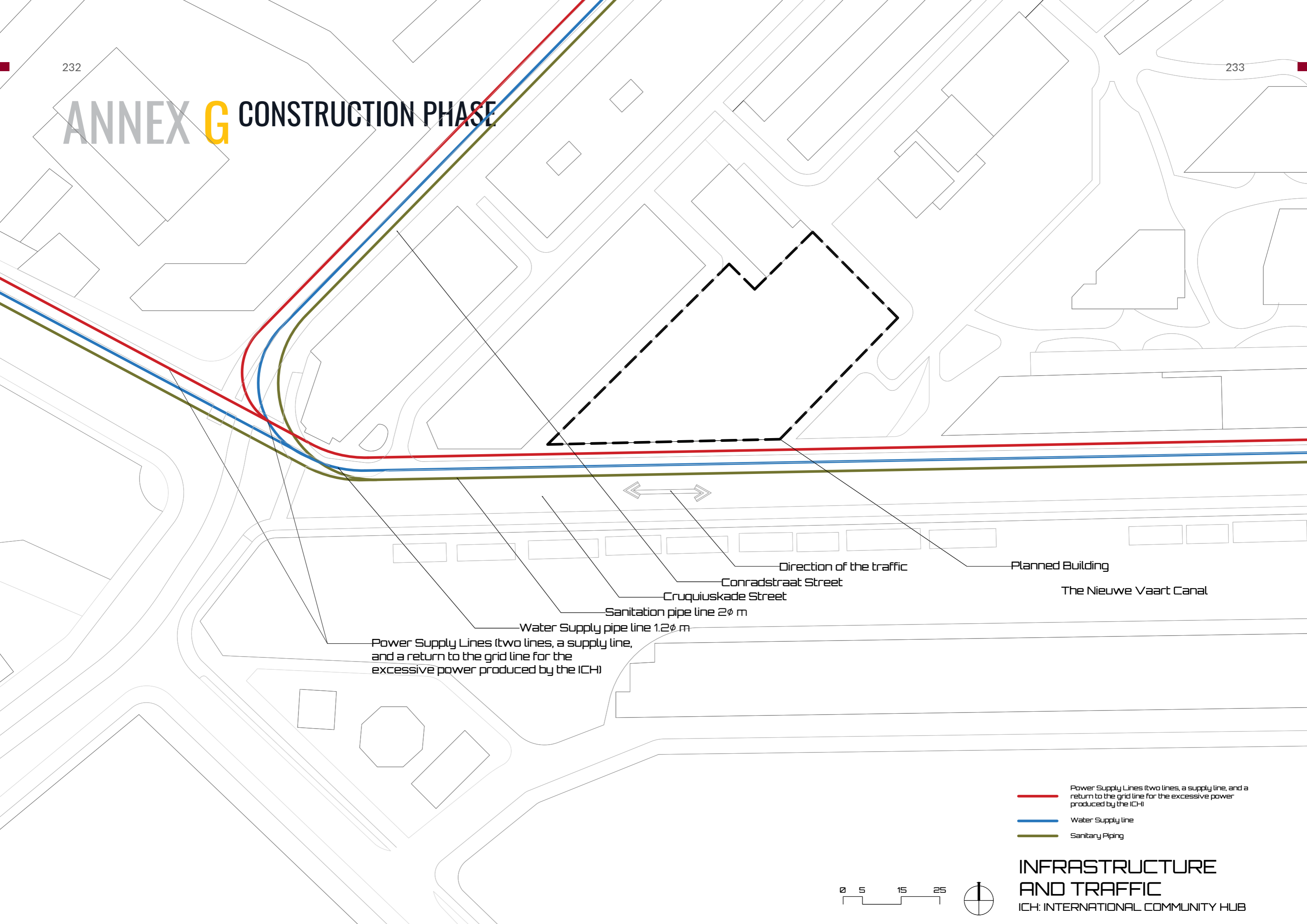

Power Supply Lines (two lines, a supply line, and a return to the grid line for the excessive power produced by the ICH)

Water Supply pipe line 1.2 ϕ m

Sanitation pipe line 2 ϕ m

Cruquiuskade Street

Conradstraat Street

Direction of the traffic

Planned Building

The Nieuwe Vaart Canal

- Power Supply Lines (two lines, a supply line, and a return to the grid line for the excessive power produced by the ICH)
- Water Supply line
- Sanitary Piping



ANNEX G CONSTRUCTION PHASE

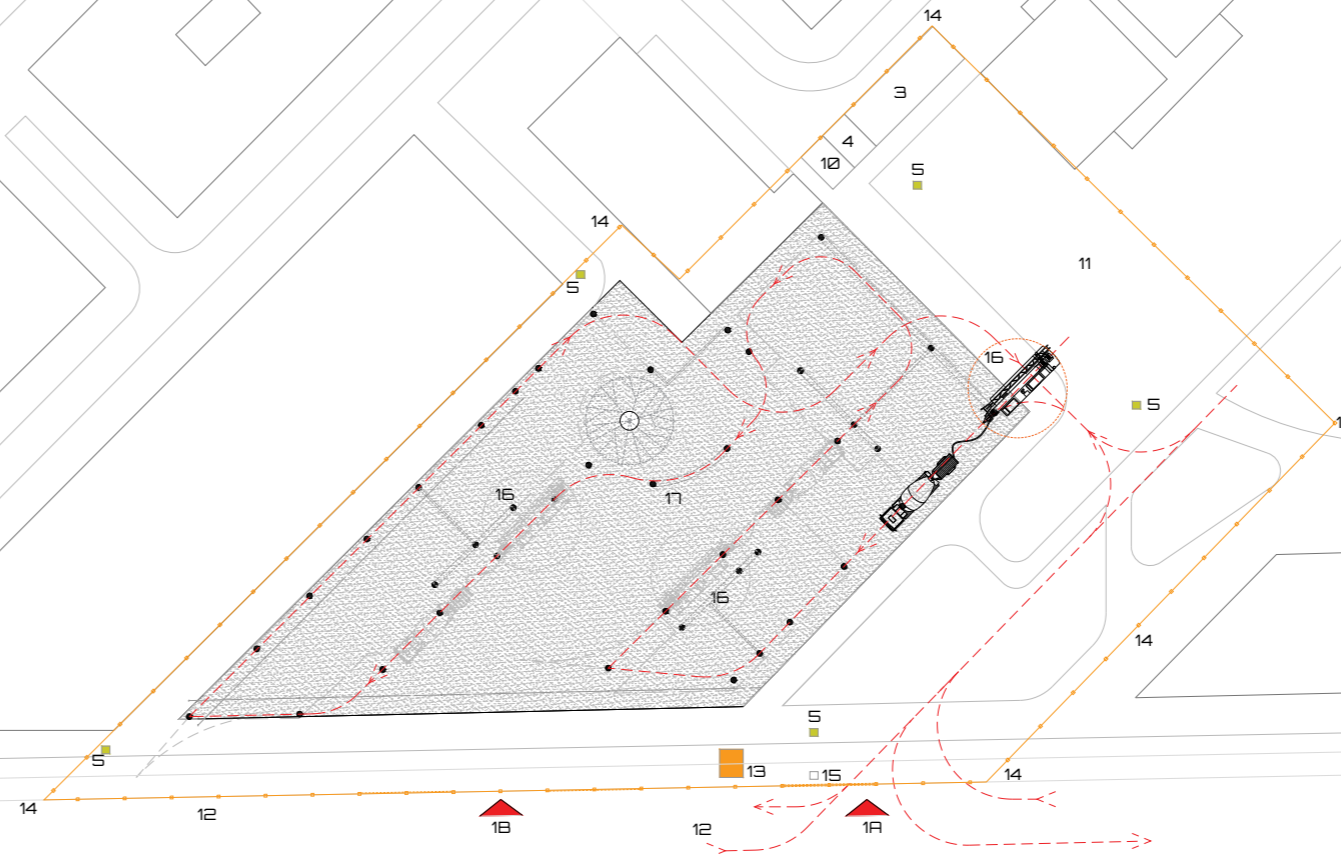

Legend:

- | | | |
|---|--|--|
| 1. A. ENTRANCE TO THE ICH SITE
B. SECONDARY ENTRANCE | 9. TEMPORARY STORAGE
(CLOSED) | 15. GENERATOR |
| 2. VEHICLE + HEAVY MACHINERY
PARKING | 10. FIRST AID POINT | 16. MACHINERY COVERAGE |
| 3. STAFF OFFICES/RESTING AREA | 11. STORING AREA AND
EQUIPMENT (OPEN) | 17. ICH SITE CLEARED AND
STRIPPED OFF TOPSOIL |
| 4. STAFF TOILETS | 12. TRANSPORTATION ROUTES
FOR MACHINERY | 18. SCAFFOLDING |
| 5. BENCHMARK / STATIONS | 13. GUARD POST | 19. MOVABLE SCAFFOLDING |
| 6. GUARD ROOM | 14. 2 M HIGH CHAINLINK FENCE | 20. FORMWORK |
| 7. ON-SITE CONSTRUCTION
WORKSHOP AREA (SHADED) | | 21. CONSTRUCTION ELEVATOR |
| 8. CRANE | | |

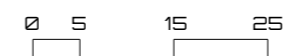

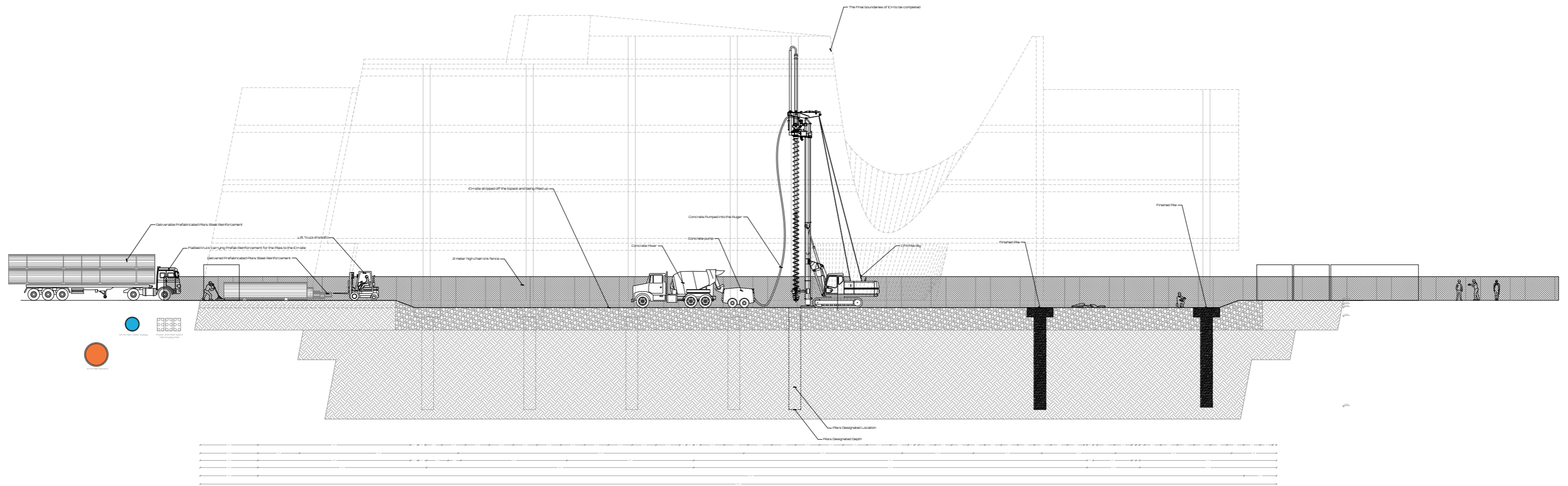

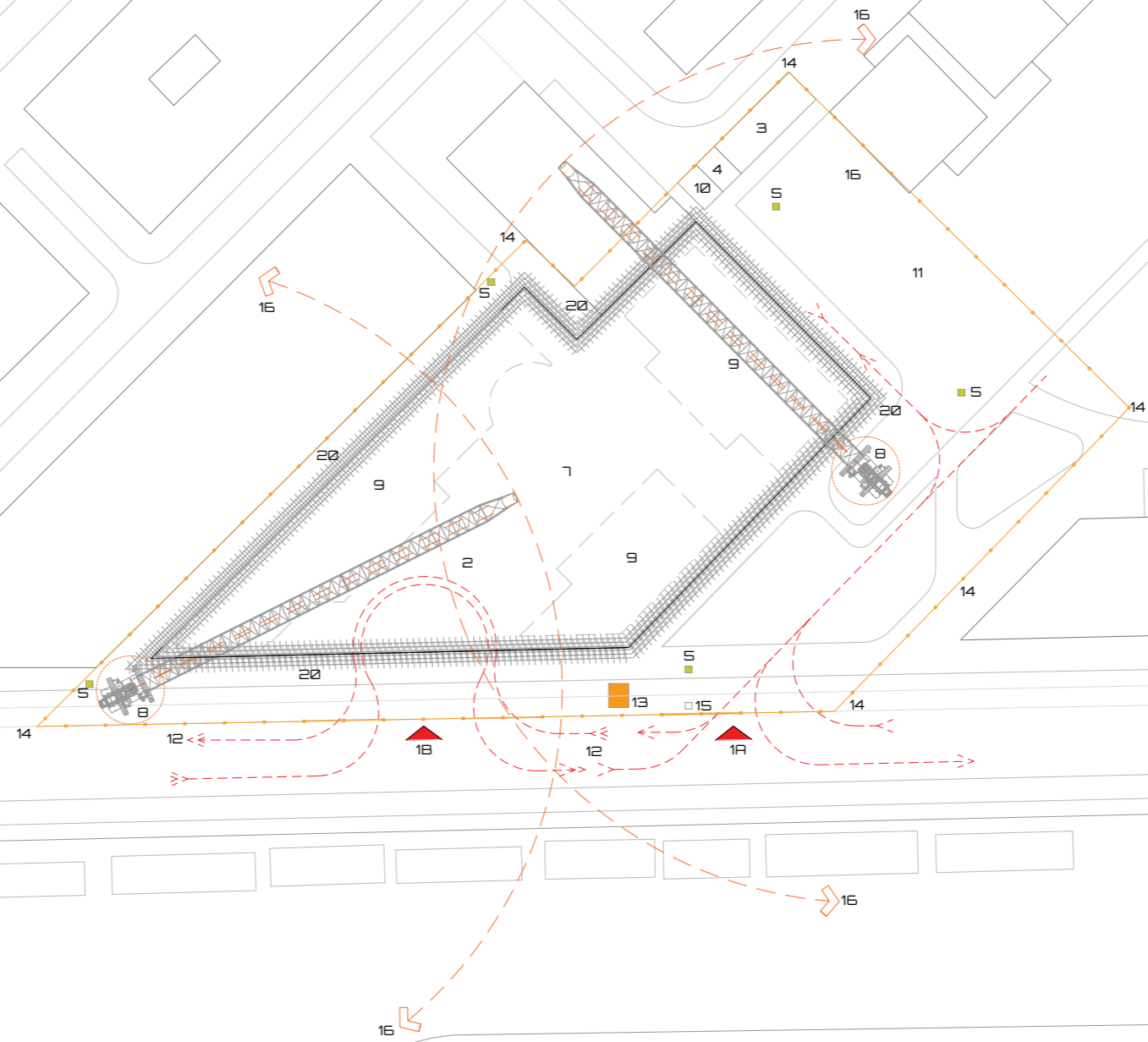

Legend:

- | | | |
|--|---|---|
| 1. A. ENTRANCE TO THE ICH SITE | 9. TEMPORARY STORAGE (CLOSED) | 15. GENERATOR |
| B. SECONDARY ENTRANCE | 10. FIRST AID POINT | 16. MACHINERY COVERAGE |
| 2. VEHICLE + HEAVY MACHINERY PARKING | 11. STORING AREA AND EQUIPMENT (OPEN) | 17. ICH SITE CLEARED AND STRIPPED OFF TOPSOIL |
| 3. STAFF OFFICES/RESTING AREA | 12. TRANSPORTATION ROUTES FOR MACHINERY | 18. SCAFFOLDING |
| 4. STAFF TOILETS | 13. GUARD POST | 19. MOVABLE SCAFFOLDING |
| 5. BENCHMARK / STATIONS | 14. 2 M HIGH CHAINLINK FENCE | 20. FORMWORK |
| 6. GUARD ROOM | | 21. CONSTRUCTION ELEVATOR |
| 7. ON-SITE CONSTRUCTION WORKSHOP AREA (SHADED) | | |
| 8. CRANE | | |



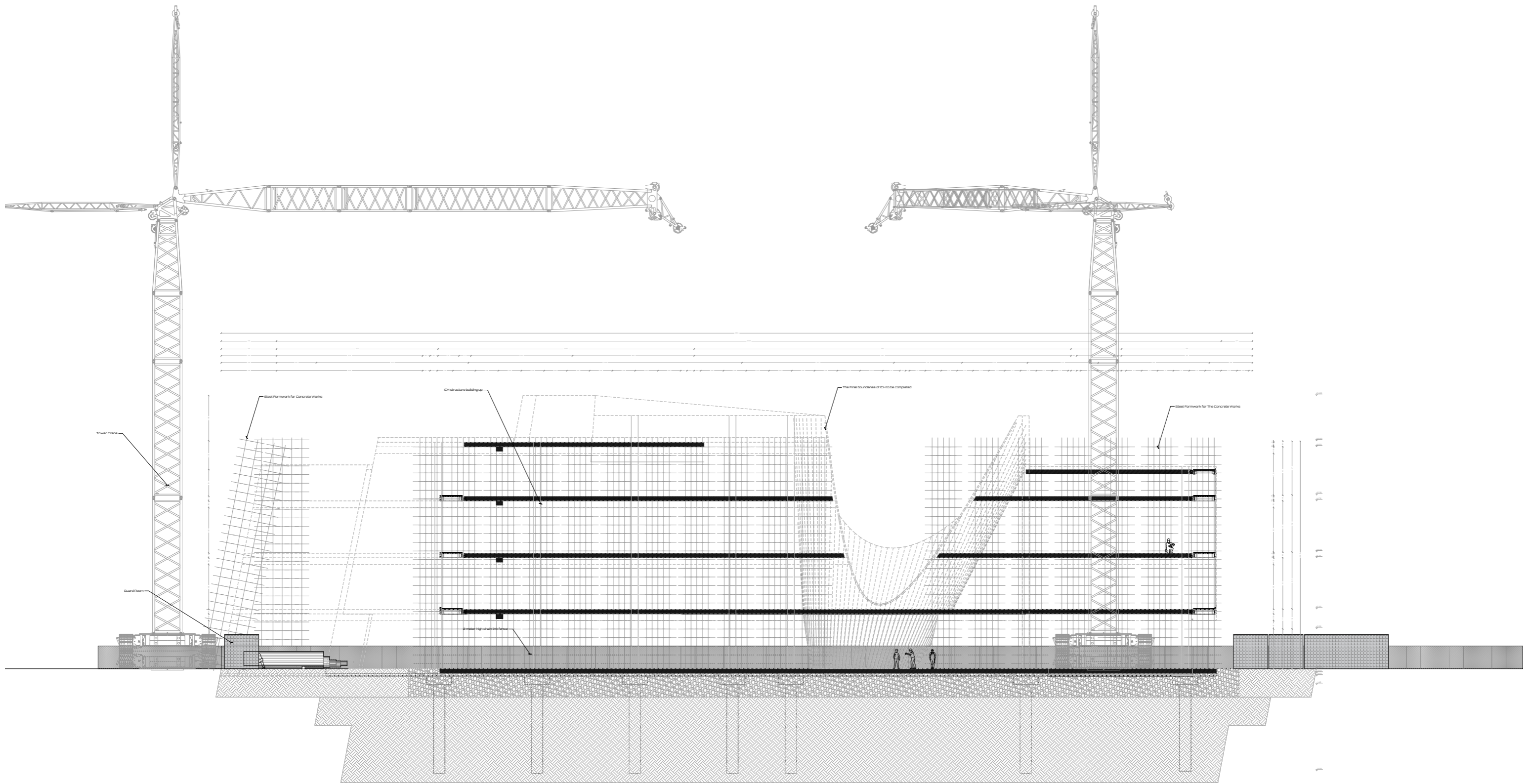

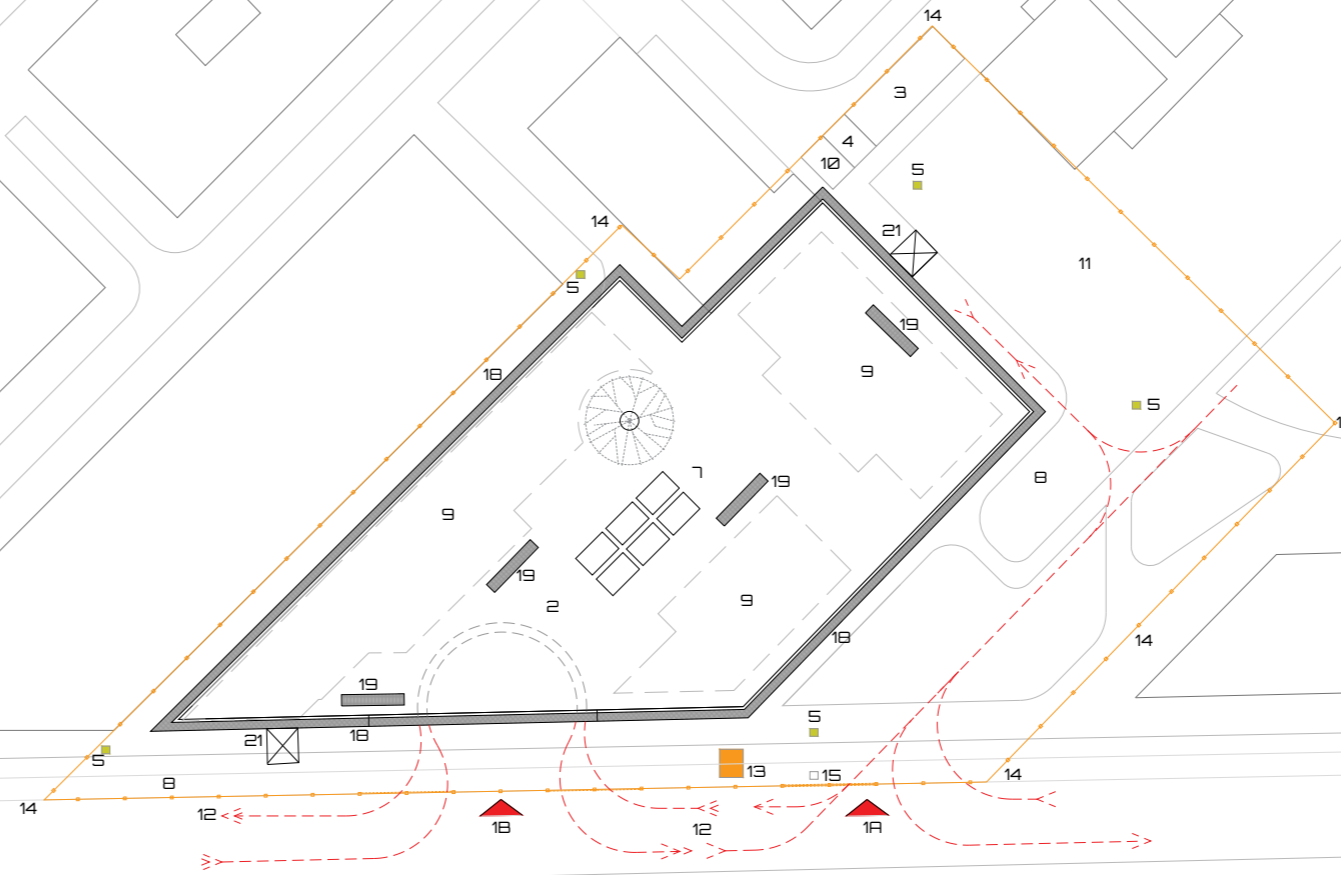

Legend:

- | | | |
|--|---|---|
| 1. A. ENTRANCE TO THE ICH SITE | 9. TEMPORARY STORAGE (CLOSED) | 15. GENERATOR |
| B. SECONDARY ENTRANCE | 10. FIRST AID POINT | 16. MACHINERY COVERAGE |
| 2. VEHICLE + HEAVY MACHINERY PARKING | 11. STORING AREA AND EQUIPMENT (OPEN) | 17. ICH SITE CLEARED AND STRIPPED OFF TOPSOIL |
| 3. STAFF OFFICES/RESTING AREA | 12. TRANSPORTATION ROUTES FOR MACHINERY | 18. SCAFFOLDING |
| 4. STAFF TOILETS | 13. GUARD POST | 19. MOVABLE SCAFFOLDING |
| 5. BENCHMARK / STATIONS | 14. 2 M HIGH CHAINLINK FENCE | 20. FORMWORK |
| 6. GUARD ROOM | | 21. CONSTRUCTION ELEVATOR |
| 7. ON-SITE CONSTRUCTION WORKSHOP AREA (SHADED) | | |
| 8. CRANE | | |



EXTERIOR FINISHING PHASE

ICH: INTERNATIONAL COMMUNITY HUB

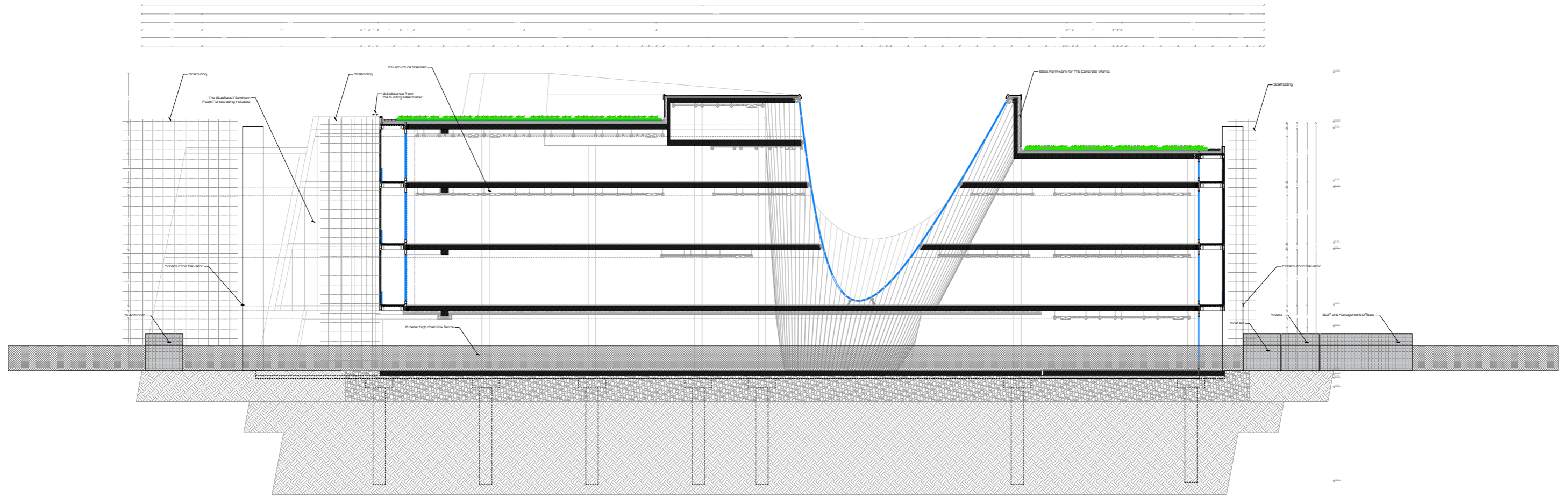

Longitudinal Section A-A
1:50



ANNEX H FURTHER BUDGETING AND SCHEDULING

Task	Time norm	Cost norm	Time (Hr)	Length-depth (M)	Element Number	Area (M ²)	Volume(M ³)	The Cost (€)
Site works								
removing topsoil (25cm)	0.3 h/m ²	17.2 €/m ²	750	0.25		2500	625	EUR 10,812.50
excavation of pit with machinery	0.05 h/m ³	8.64 €/m ³	0.2125	8.5	43	0.5	4.25	EUR 1,578.96
Foundations								
CPA Pile Deep Foundation	0.33 h /Pile	621€/Pile	14.19		43			EUR 26,703.00
Concrete works								
GroundFloor RC Slab	0.9 h/m ³	346 €/m ³	540	0.5		1200	600	EUR 207,600.00
GroundFloor RC Walls	6.78 h/m ³	346 €/m ³	1491.6	0.5		440	220	EUR 76,120.00
GroundFloor RC Columns	0.83 h/m ³	346 €/m ³	85.656	4.8	43	21.5	103.2	EUR 35,707.20
First Floor RC Slab	0.9 h/m ³	346 €/m ³	900	0.5		2000	1000	EUR 346,000.00
First Floor RC Walls	6.78 h/m ³	346 €/m ³	1237.35	0.5		365	182.5	EUR 63,145.00
First Floor RC Columns	0.83 h/m ³	346 €/m ³	85.656	4.8	43	21.5	103.2	EUR 35,707.20
SecondFloor RC Slab	0.9 h/m ³	346 €/m ³	843.75	0.5		1875	937.5	EUR 324,375.00
SecondFloor RC Walls	6.78 h/m ³	346 €/m ³	1057.68	0.5		312	156	EUR 53,976.00
SecondFloor RC Columns	0.83 h/m ³	346 €/m ³	85.656	4.8	43	21.5	103.2	EUR 35,707.20
ThirdFloor RC Slab	0.9 h/m ³	346 €/m ³	306	0.5		680	340	EUR 117,640.00
ThirdFloor RC Walls	6.78 h/m ³	346 €/m ³	1356	0.5		400	200	EUR 69,200.00
ThirdFloor RC Columns	0.83 h/m ³	346 €/m ³	85.656	4.8	43	21.5	103.2	EUR 35,707.20
Roofing								
Roof - battens for the tiles		4.3 €/m ²				1970		EUR 8,471.00
Roof foils		3 €/m ²		50		1970		EUR 5,910.00
Insulation								
mineral wool insulation	1.06 h/m ²	27.5 €/m ²	73.564	347		69.4		EUR 1,908.50
EPS Roof insulation	1.25 h/m ²	20.5 €/m ²	2975			2380		EUR 48,790.00
Exterior Finishes								
external cladding aluminum	1.2 h/m ²	103.8 €/m ²	23616	820	24	19680		EUR 2,042,784.00
Curtain Walls		432.7€/m ²		4.8		2760		EUR 1,194,252.00
Partitions								
10 cm gypsum/plaster partition		30 €/m ²		150		720		EUR 21,600.00
20 cm thermal and acoustic insulating blocks		55 €/m ²		107		513.6		EUR 28,248.00
Smart glass panels		288.5 €/m ²		140		672		EUR 193,872.00
Floor Finishes								
Ceramic Tile	1.1 h/m ²	36 €/m ²	539			490		EUR 17,640.00
Install Wood Flooring (Install)		35 €/m ²			5 Floors	270		EUR 9,450.00
Install Polished Concrete Floor		50 €/m ²			5 Floors	4900		EUR 147,000.00
Paints								
Prime Paint Drywall		25.9€/m ²		360		1728		EUR 44,755.20

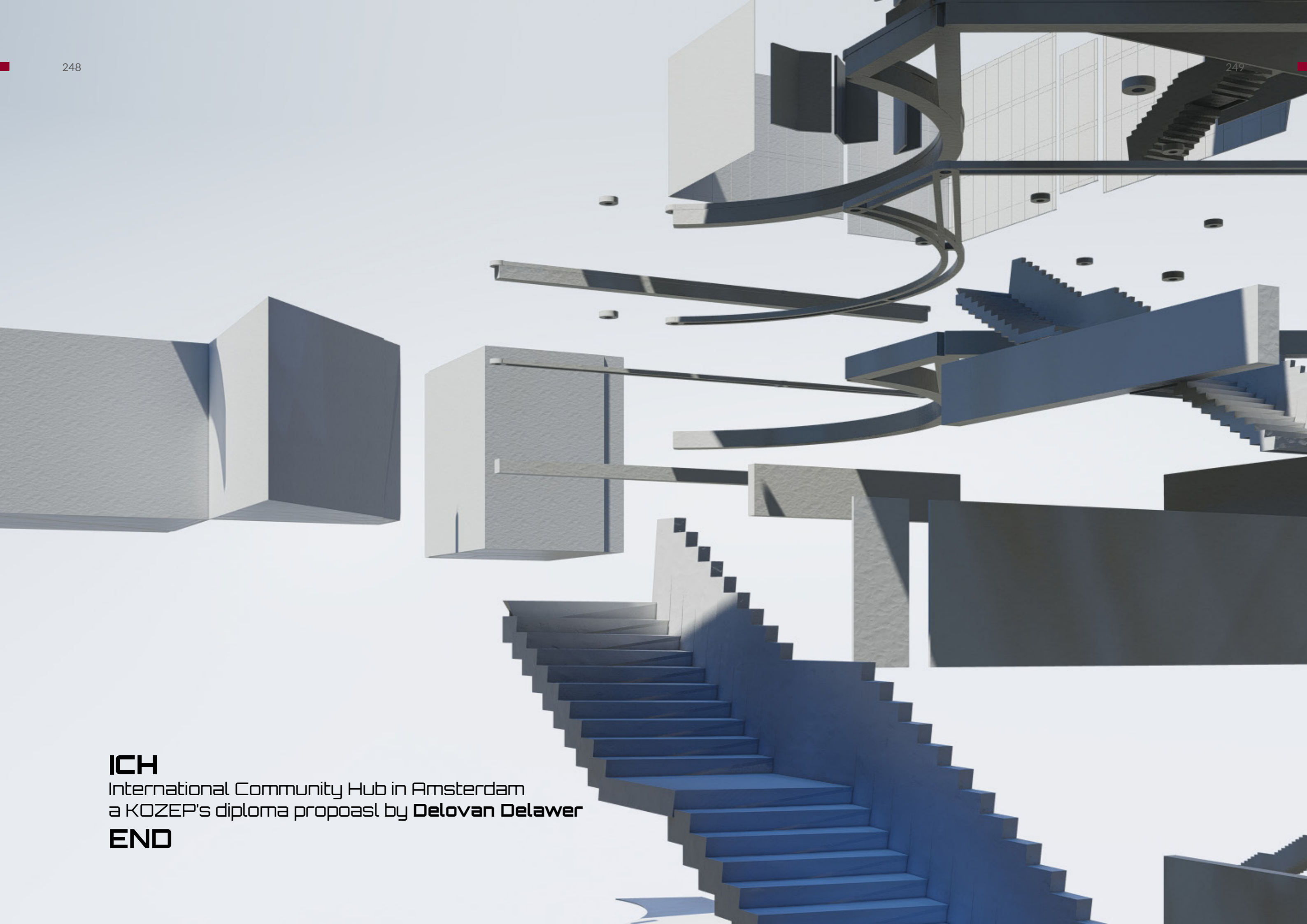

ICH

International Community Hub in Amsterdam
a KOZEP's diploma proposal by **Delovan Delawer**

END